

# THE SAPHIR DETECTOR

*Ch. Theisen, C. Gautherin, M. Houry, W. Korten  
Y. Le Coz and R. Lucas  
CEA/DSM/DAPNIA/SPhN Saclay*

*G. Barreau, Ch. Badimon and T.P. Doan  
CENBG Bordeaux*

*V. Méot and G. Bélier  
CEA/DAM/SPN Bruyères le Châtel*

March, 1997

## Résumé

Le détecteur SAPHIR ( Saclay Aquitaine Photovoltaic cells for Isover Research ) est un ensemble constitué de cellules photovoltaïques dédié à la détection de fragments de fission. Ce détecteur est destiné à être couplé à des multidétecteurs  $\gamma$  comme Euroball ou Exogam.

Ce type original de détecteur présente de nombreux avantages par rapport aux détecteurs barrières de surface ou aux détecteurs à gaz ( souplesse d'utilisation, géométrie modulable, bonne tenue sous faisceau, faible coût ) pour des performances voisines.

Dans ce document, nous décrivons les domaines de physique que nous pouvons aborder avec un tel détecteur : mécanisme de réaction, structure nucléaire et spectroscopie (spectroscopie des actinides, des noyaux de la région plomb - thorium et des noyaux riches en neutrons produits par fission induite ou spontanée ). Nous décrivons ensuite le fonctionnement des cellules, les performances d'un ensemble composé de cellules, ainsi que l'électronique associée.

Les performances comparées entre des cellules photovoltaïques et des barrières de surfaces, ainsi que l'électronique VXI développée pour un tel ensemble sont exposées en annexe.

# Introduction

SAPhIR is the acronym for Saclay Aquitaine Photovoltaic cells for Isomer Research. It consists of solar cells, used for fission-fragment detection. It is a collaboration between 3 laboratories : CEA Saclay, CENBG Bordeaux and CEA Bruyères le Châtel.

The study of rotating nuclei has led to more and more exclusive measurements. Experimentally, much effort has been paid to build efficient devices to detect light charged particles emitted in coincidence with  $\gamma$  rays. This is the case for the CsI based  $4\pi$  detector DIAMANT which has been built in Bordeaux. Up to now, no such device has been considered for fission, although this process plays already a significant role in heavy ion induced reactions on targets of  $A > 100$ . The coupling of a large efficient fission-fragment detector like SAPhIR with EUROBALL will provide new insights in the study of very deformed nuclear matter and the spectroscopy of neutron rich-nuclei.

## 1 Applications

The physics we want to address with SAPhIR should be manifold when used with the already existing large arrays for  $\gamma$  rays, neutrons or light charged particles.

- Reaction mechanisms
  - Fission dynamics and nuclear dissipation.
  - stability against fission of highly deformed states.
- Nuclear structure and spectroscopy
  - Actinide region : search for superdeformed states of  $J > 8\hbar$  built on fission isomers. SAPhIR is then used as a filter for delayed fission fragments.
  - Lead-Thorium region : Very few superdeformed states at the border of this region are known. Because of the competition between fission and fusion-evaporation, SAPhIR can be used as a veto against fission. In this case, a  $4\pi$  geometry is necessary.
  - Fission-fragment spectroscopy of very neutron-rich nuclei produced in induced or spontaneous fission. SAPhIR is then used for mass identification, trigger and kinematic reconstruction of the fission events (Doppler correction).

To face the preceding items, SAPhIR has been designed to meet the following requirements :

- good fission channel selectivity with the possibility to detect the 2 fission fragments in coincidence.
- large efficiency and good granularity together with a size suitable to fit into the scattering chamber of EUROBALL.
- weak absorption of  $\gamma$  rays in order to preserve the peak-to-total ratio and hence the sensitivity of EUROBALL.

## 2 Description of the photovoltaic cells

Usually, surface-barrier detectors or gas-avalanche counters are used to detect fission fragments, but the cost of building a large array with surface-barrier detectors is high and they exhibit severe radiation damage problems. On the other hand, gas detectors are difficult to handle and require special care because of the thin window. We have tested with success solar cells, the capabilities of which have been demonstrated by G. Siegert in 1979. A few studies have been reported so far [1, 2, 3].

The solar cells we are using have an area of about  $3 \text{ cm}^2$ . They are made from a polycrystalline silicon p-type wafer with a thickness of  $300 \text{ }\mu\text{m}$ . As shown in figure 2.1, the front face of the cell consists of an Ag grid covered with a thin antireflection titanium-oxide layer. The charge collection is done through a thin Ag backing evaporated on the rear side of the wafer.

The semi-conductor structure pn+ junction is similar to those of surface-barrier detectors. Owing to the low resistivity of the substrate ( $< 3\Omega/\text{cm}^2$ ), the depletion depth does not exceed  $0.1 \text{ }\mu\text{m}$  and the solar cell operates without any bias voltage. Therefore, light charged particles (e, p and  $\alpha\dots$ ) loose only a small energy in the depletion zone. The charge collection is performed through a complex mechanism (the funneling [4]) that we will not describe here. This process depends strongly on the specific ionisation ( $dE/dx$ ) so that the response of the solar cells to heavy ionizing particles is enhanced compared to light charged particles.

The detectors are able to detect charged particles (as standard surface-barriers), but a limitation arises from the large capacitance ( $\simeq 30\text{nF}/\text{cm}^2$ ) : the signal extracted from the preamplifiers is small and light particles cannot be distinguished from the noise. The cells have been tested to work well for heavier particles with  $A > 50$  and  $E > 30 \text{ MeV}$ .

Due to the well known pulse-height defect effect, the particle energy  $E$  is related to the measured signal  $x$  by the relation :

$$E = (a + a'M)x + (b + b'M). \quad (1)$$

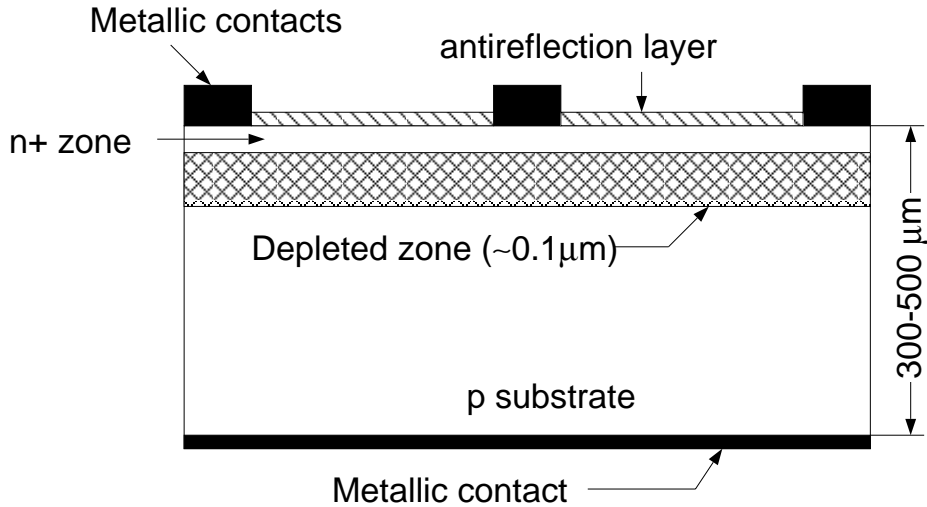

Figure 2.1: A photovoltaic cell

a, a', b, b' are extracted from the "Schmitt calibration" method [5], and are very similar to those of standard surface-barriers detectors.

### 3 Performance of the photovoltaic cells

The response of the solar cells to fission fragments has been studied by using a thin open source of the spontaneously fissioning isotope  $^{252}\text{Cf}$  widely used to study the performances of heavy-ion detectors. A careful comparison has been made with a standard surface-barrier detector (see annex A for details).

The mass resolution expected from a typical double-energy measurement is around 4 to 5 amu using surface-barrier detectors : this includes intrinsic energy resolution, quality of the target and its backing as well as prompt neutron emission from the fragments. The mass resolution using solar cells has been estimated to 7-8 amu with the present techniques.

A part of this value could be related to the direct use of Schmitt-calibration constants recommended for surface-barrier detectors, but these constants could be different for solar cells due to the antireflection coating and the charge collection mechanism. To overcome this problem, an independent determination of these constants will be carried out.

In conclusion, we have determined that the energy resolution is roughly 3 times larger

than those of surface-barrier detectors.

The detection efficiency has been found to be  $\simeq 1$ .

The time resolution is around 20 ns.

## 4 Interference with $\gamma$ detection

The detectors are usually used on an epoxy support. Only X-rays are attenuated in this configuration while  $\gamma$ -ray transmission is near 100 %. Attenuation due to support, preamplifiers, etc.. has to be determined in the EUROBALL configuration.

## 5 Electronics

Owing to the large capacitance of the solar cells (20-30 nF/cm<sup>2</sup>), a specific charge-sensitive preamplifier has been developed to extract both energy and timing signals. To minimize pick-up and noise pile-up, the preamplifiers (3\*4 cm<sup>2</sup>) are housed inside the scattering chamber nearby the solar cells. Smaller preamplifiers (2\*2 cm<sup>2</sup>) are under construction in Saclay.

Linear amplifiers and timing amplifiers have been designed starting from the DIAMANT electronics modules with shaping-time constants adapted to the solar cells. They are grouped in 4 NIM modules of 8 channels each, so 32 detection channels will be available for the first campaign of measurement in Legnaro.

For the first EUROBALL-SAPhIR experiment (experiment 97.50), the encoding of the solar-cell signals will be done with FERA-ADC modules (LeCroy). The read-out of the ADC's and the coupling to the EUROBALL readout data stream will be performed with the FERA-VXI card developed by CENBG Bordeaux.

During two previous experiments at EUROGAM II, Ge Phase I cards have been used directly to couple SAPhIR to the VXI data acquisition (see annex B.1) and very encouraging results have been obtained (for the first time EUROGAM has been run in prompt and delayed coincidences with an external ancillary detector). Therefore, future EUROBALL-SAPhIR experiments will use a fully integrated VXI electronics.

For that purpose, new VXI cards (including both time and energy channels) dedicated to SAPhIR or other Si ancillary detectors are under development at CEA Saclay, and should be available at the end of 1997 (see annex B.2 for details).

## 6 Geometry

The geometrical arrangement will be as versatile as possible keeping in mind that it should be small enough to fit inside a EUROBALL scattering chamber which will be designed at Bordeaux. The simplicity and low cost of the solar cells will allow to face various experimental situations depending on the kinematics of the reaction : large solid-angle coverage to maximize fission-fragments detection efficiency, good granularity for Doppler correction, etc...

In the past we have used two different setups at EUROGAM for the study of spontaneous fission of  $^{252}\text{Cf}$  and proton-induced fission of  $^{232}\text{Th}$  (see figure 6.2). For the experiment EUROBALL 97.50, we will use the setup described on the lower part of figure 6.2.

Moreover, the cells can be cut in any shape used for any geometry and even a hole can also be made in the cells, for example in the beam axis.

## 7 Count rates, limitation

The detectors have been used for off-beam and in-beam experiments. We have been working up to 5kHz counting rate without a severe degradation of the observed signal. Even after the detectors have been placed directly in the beam, they were still working.

Solar cells ( as surface-barrier detectors) could be sensitive to charge build-up resulting from target electrons when using intense heavy-ion beams. Target polarization could be helpful to eliminate this problem.

## 8 Time schedule

- Nov 1995 : Experiment with 2 cells and a  $^{252}\text{Cf}$  source [6].
- Sept 1996 : Experiment with 10 cells (EUROGAM II experiment 15c) : proton-induced fission of  $^{232}\text{Th}$ .
- 1997 : new preamplifiers.
- 1997 : new Schmitt calibration.
- Middle 1997 : Experiment at EUROBALL III with 32 cells. Design and construction of the setup at Bordeaux begin of 1997.
- End 1997 : 48 VXI channels available.

## EUROGAM II Experiments :

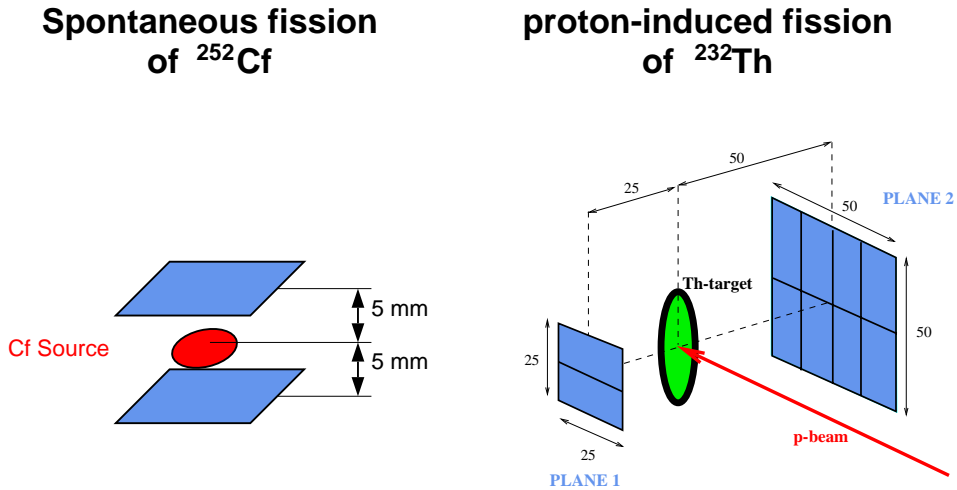

## EUROBALL III Experiment :

### Carbon-induced fission of $^{238}\text{U}$

$^{238}\text{U} + ^{12}\text{C}$  at 100 MeV :  
SAPhIR Setup.  
- 32 photovoltaic cells.  
- 45 % efficiency.

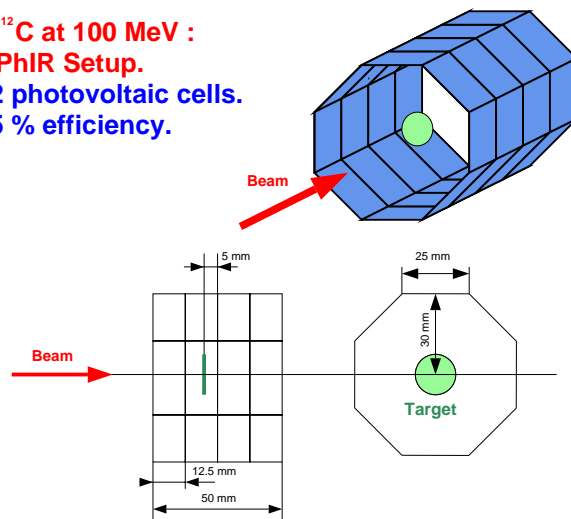

Figure 6.2: Experimental setups used for experiments with EUROGAM and EUROBALL.

- 1998 : possibility to use 48 cells in a near- $4\pi$  geometry.

## 9 Funding

SAPhIR is funded by 3 laboratories : CEA Saclay, CENBG Bordeaux and CEA Bruyères le Châtel.

The cost including mechanics, electronics and acquisition is 1315 kF and is shared between the 3 laboratories as follows :

- 69.6 % CEA Saclay.
- 22.8 % CENBG Bordeaux.
- 7.6 % CEA Bruyères le Châtel.

A Memorandum of Understanding concerning the building and use of SAPhIR has been signed in 1996 between the 3 laboratories.

# A Comparison between photovoltaic cells and surface-barriers with a $^{252}\text{Cf}$ source

The pulse height spectra obtained with a solar cell and a surface-barrier detector are shown in figure A.3; they clearly exhibit the peaks corresponding to the heavy and light fragments groups.

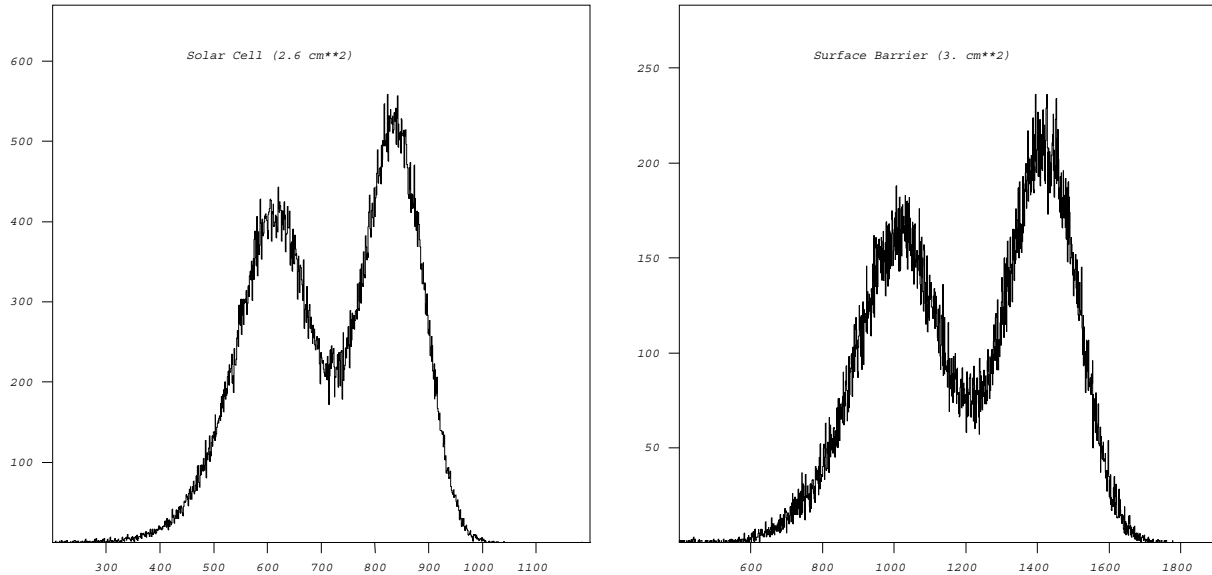

Figure A.3: Pulse height spectra obtained with a solar cell (left) and a surface-barrier detector (right).

A shape analysis of these spectra has been performed following the Schmitt-Pleasanton criteria recommended for surface-barrier detectors : the comparison has been done in terms of the ratios of the maximum counting rates of the heavy ( $N_H$ ) and light ( $N_L$ ) peaks, with the minimum of the valley ( $N_V$ ) in between. The measured values are reported in table A.1. We note that the 2.6 cm<sup>2</sup> solar cell results agree fairly well with the values quoted for the surface-barrier detectors.

The relative widths of the heavy and light group are larger than the corresponding width for the surface-barrier detectors. This effect may result from non-uniformities in the titanium-oxide coating as well as from the funneling mechanism, both of which depend on the fragment masses, charges and energies. Such a dependence has been known for a long time for surface-barrier detectors. This effect is described by the pulse-height defect which is defined as the difference between the energy of a fission fragment of a given mass and that of an  $\alpha$  particle required to produce the same pulse height in the detector. The

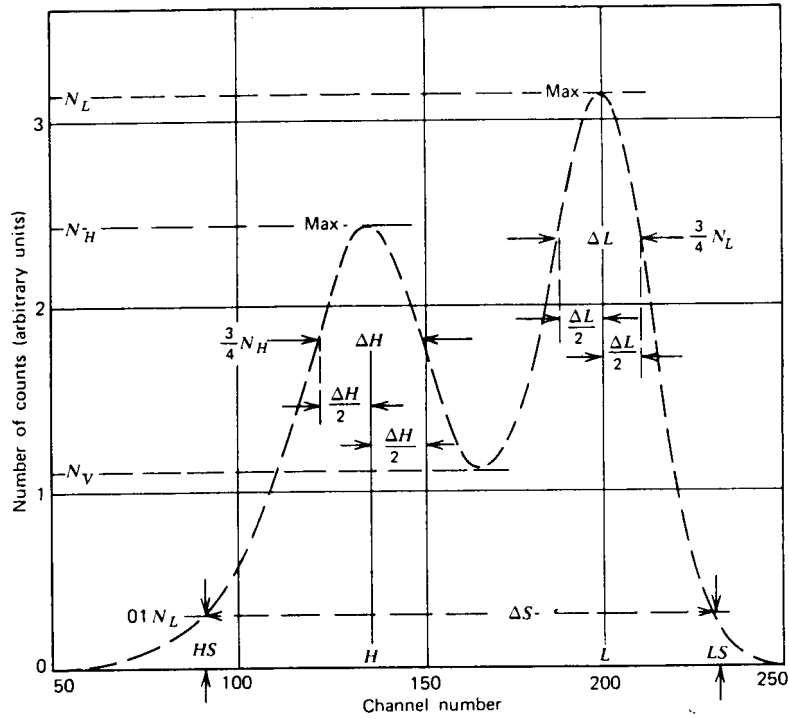

Figure A.4:

Schmitt-Pleasanton reference spectrum (Figure from ref [7], p379).

Spectrum Parameter	P.V. 2.6 cm <sup>2</sup>	P.V. 5.6 cm <sup>2</sup>	S.B 3.14 cm <sup>2</sup>	Ideal limit
$N_L/N_V$	2.31	1.84	2.73	> 2.85
$N_H/N_V$	1.88	1.54	2.09	2.20
$N_L/N_H$	1.23	1.20	1.30	1.30
$\Delta L/L-H$	0.48	0.48	0.33	< 0.38
$\Delta H/L-H$	0.52	0.55	0.50	< 0.45
$(H-HS)/L-H$	0.79	0.83	0.73	< 0.70
$(L-LS)/L-H$	0.50	0.62	0.57	< 0.49
$(LS-HS)/L-H$	2.29	2.45	2.30	< 2.18

Table A.1: Values extracted from the Schmitt-Pleasanton reference spectrum. Two photovoltaic cells (P.V.) of different size and a surface-barrier (S.B.) have been used.

so called Schmitt calibration method takes into account this phenomenon for the energy response of heavy ion surface-barrier detectors. A similar pulse height defect has been observed for solar cells, so the same procedure has been used here to calibrate the solar cells.

This energy calibration will be important for experiments requiring double energy measurements to determine both fission fragment masses and energies. The reliability of this technique has been checked with 2 solar cells detecting in coincidence the fission fragments emerging from a thin  $^{252}\text{Cf}$  source. An iterative method including the mass dependence response is used here to extract the post-mass distribution (after neutron emission). As shown in figure A.5, the derived distribution agrees well with those obtained by other techniques. Nevertheless, the loss in mass resolution is apparent from the broadening of the heavy and light groups.

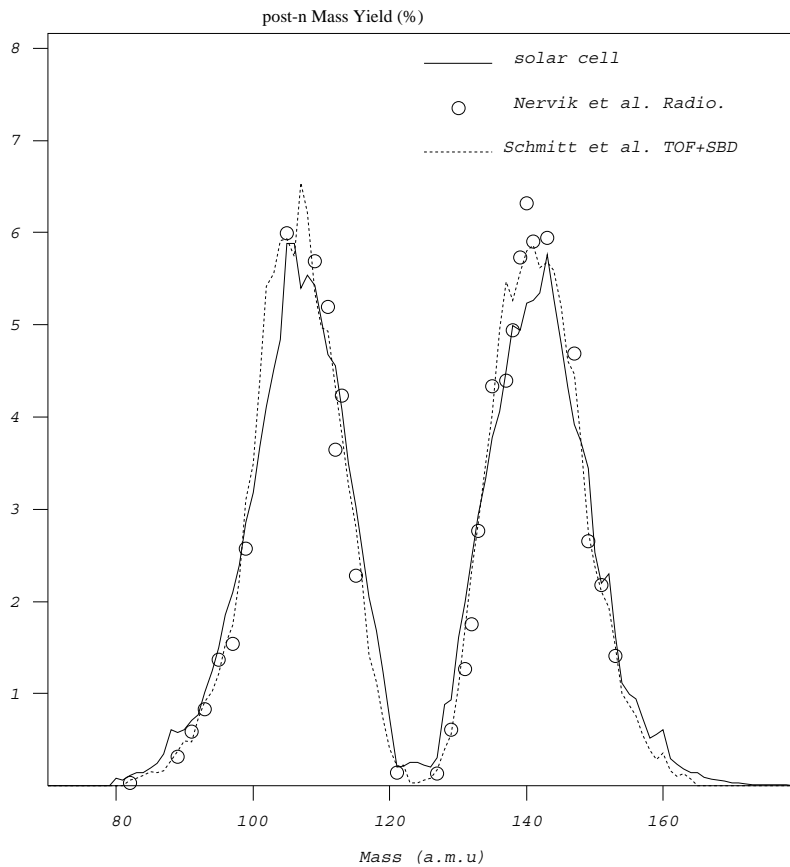

Figure A.5:

Mass spectrum obtained from a  $^{252}\text{Cf}$  source. The measurement obtained with photovoltaic cells is compared with those obtained with a standard surface-barrier detectors and radiochemical measurement [8].

# B Electronics of SAPHIR with EUROGAM and EUROBALL

## B.1 Use of Ge Phase I Cards

At EUROGAM II, we have used an original solution for the SAPHIR acquisition. It consists in using the spare Ge Phase I cards.

The setup presented in figure B.6 was used in 1995 for an experiment with 2 cells and a  $^{252}\text{Cf}$  source.

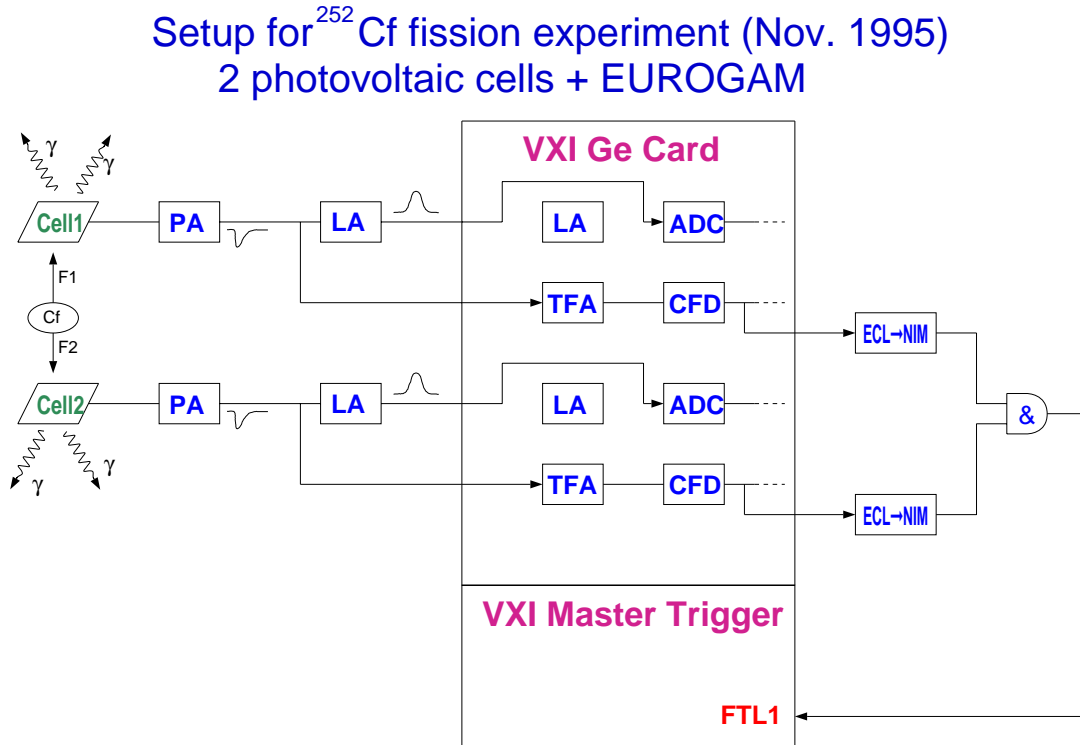

Figure B.6: Use of Ge Phase Cards for SAPHIR

The timing-filter amplifier is well adapted to the photovoltaic cell signal. However, the time constants of the linear amplifier are not well adapted so that an external linear amplifier had to be used, which is possible since the amplified signal can be directly put into the stretcher without using the internal amplifier.

In the example presented here, the trigger condition was that both cells responded. This signal was built from the CFD signal available in the front panel of the VXI card, after translation in NIM. The AND condition was then put in the master trigger card.

This solution was also used with 10 photovoltaic cells (exp 15c), and could also be used

at EUROBALL for a small number of cells (less than 12).

## B.2 The SAPHIR VXI card

The solution to use spare Ge Phase I is limited to 12 detectors since only 2 such cards are available.

For the next experiments with a larger number of cells, we have decided to design new VXI cards, presented on figure B.7.

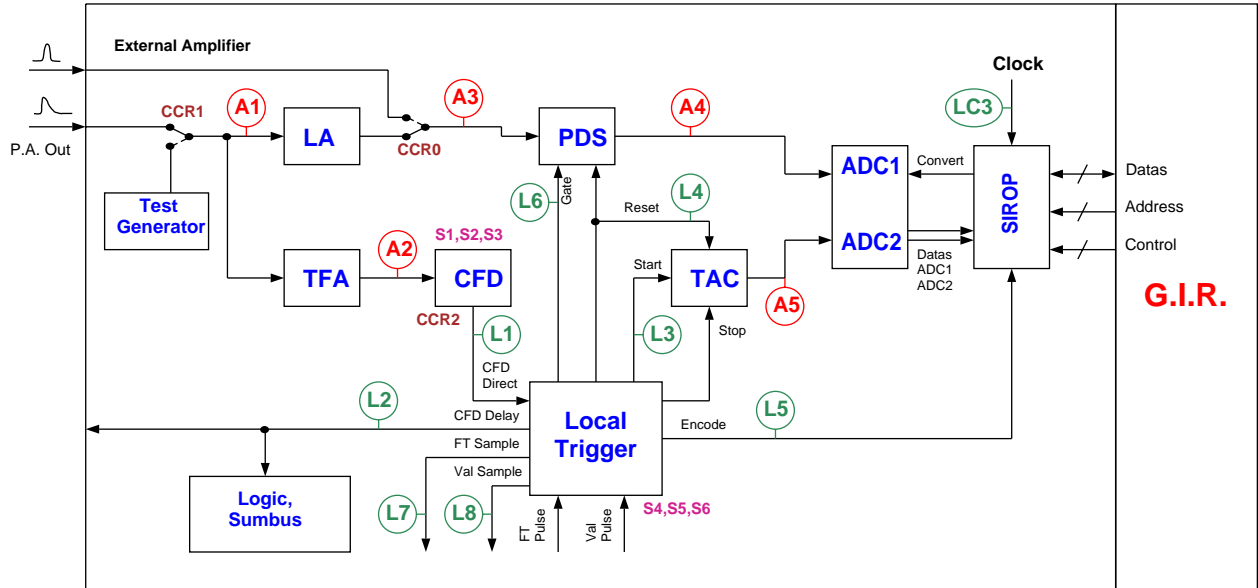

Figure B.7: The SAPHIR VXI Card

This card has the following main characteristics :

- 16 channels per card.
- Every channel is composed of
  - Energy channel : Linear Amplifier, Stretcher, ADC.
  - Time channel : Timing filter amplifier, Constant Fraction Discriminator, Time to Amplitude Converter, ADC.
  - Local Trigger.
- Possibility to by-pass the linear amplifier (external amplifier mode).
- Possibility to use positive or negative signals at the stretcher input of the PDS.
- 2 trigger signals are built into the card :

- ‘Or’ between all channels.
  - Sum bus (multiplicity signal).
  - possibility to form a daisy chain between different cards.
- Read-out is performed by the GIR interface.
  - Possibility to mark or reject pre-pileup events.

This card will also be available for any detectors requiring an energy and time treatment, since linear and timing filter amplifier will be located on daughter board and can be changed for signals which have different time constants. This is for example the case for other Si detectors, e.g. used in a conversion electron spectrometer, which can also use the SAPHIR card.

For the moment, three such cards ( plus one spare) will be built.

The SAPHIR VXI card is designed by CEA/DAPNIA/SEI electronics group (B. Cahan, X. Coppolani, B. Delaitre, A. Le Coguie and Ph. Legou) in collaboration with N. Karkour and D. Linget from C.S.N.S.M. Orsay. The control and data acquisition software is developed by CEA/DAPNIA/SIG (G. Durand and G. Carles) with the help of V. Pucknell from Daresbury Laboratory.

## References

- [1] G. Siegert. **Photovoltaic cells as fission product detectors**. N.I.M. 164 (1979) 437.
- [2] E. Liatard *et. al.* **Détection de produits de fission à l'aide de cellules photovoltaïques** N.I.M. A267 (1988) 231.
- [3] N.N Ajitanand *et. al.* **The photovoltaic cell - an eminent fission fragment detector** N.I.M. A300 (1991) 354.
- [4] F.B. McLean and T.R. Oldham. **Charge funneling in n- and p- Si substrates**. IEEE Trans. on Nucl. Sci. NS-29, No 6 (1982) 2018.
- [5] H.W. Schmitt, W.E. Kiker and C.W. Williams. **Precision measurements of correlated energies and velocities of  $^{252}\text{Cf}$  fission fragments**. Phys. Rev. 137 (1965) B837.
- [6] C. Gautherin *et. al.* To be published.
- [7] G.F. Knoll. **Radiation detection and Measurement**. Second edition, Wiley & Sons, Inc, 1989.
- [8] W.E. Nervik. **Spontaneous fission yields of  $^{252}\text{Cf}$** . Phys. Rev. 119 (1960) 1685.