



INFN Frascati National Labs today



- Main Facilities and Activities of the Laboratory
- Focus on the Nuclear and Hadronic Physics.

Valeria Muccifora

Frascati National Labs (LNF)

Total Staff of which: 293	Researchers 80	Technologist / Engineers 38	Technicians 142	Administration/ Services 33
External Users 501	<i>Italian</i> 257		<i>Foreign</i> 244	
Visitors 3426	Stages 184	Conference Workshops 21	Participants to Seminars 765	Course for teachers of high school 172

Electro-synchrotron in Frascati 1959-1975

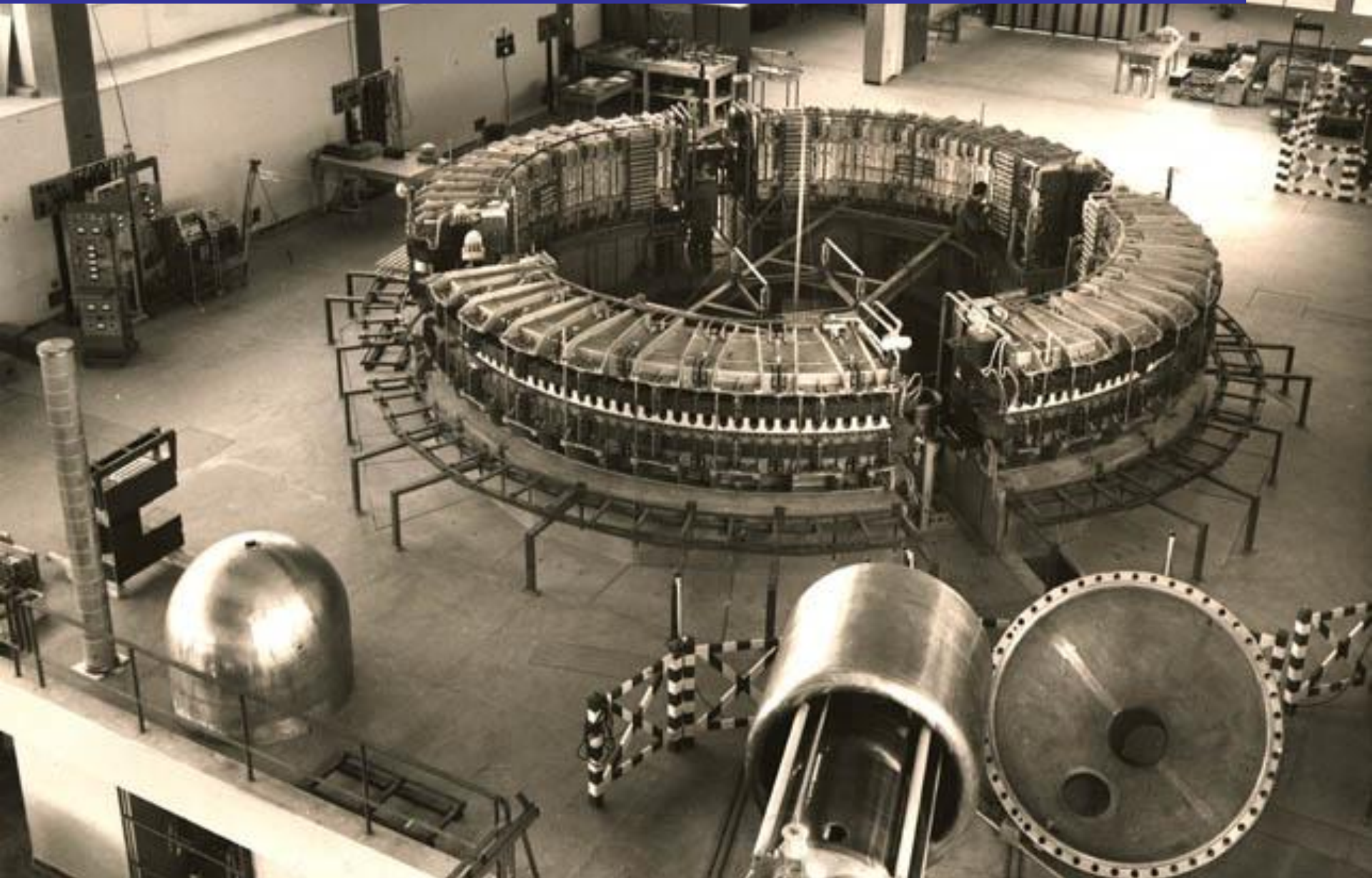

ΔΑΦΝΕ

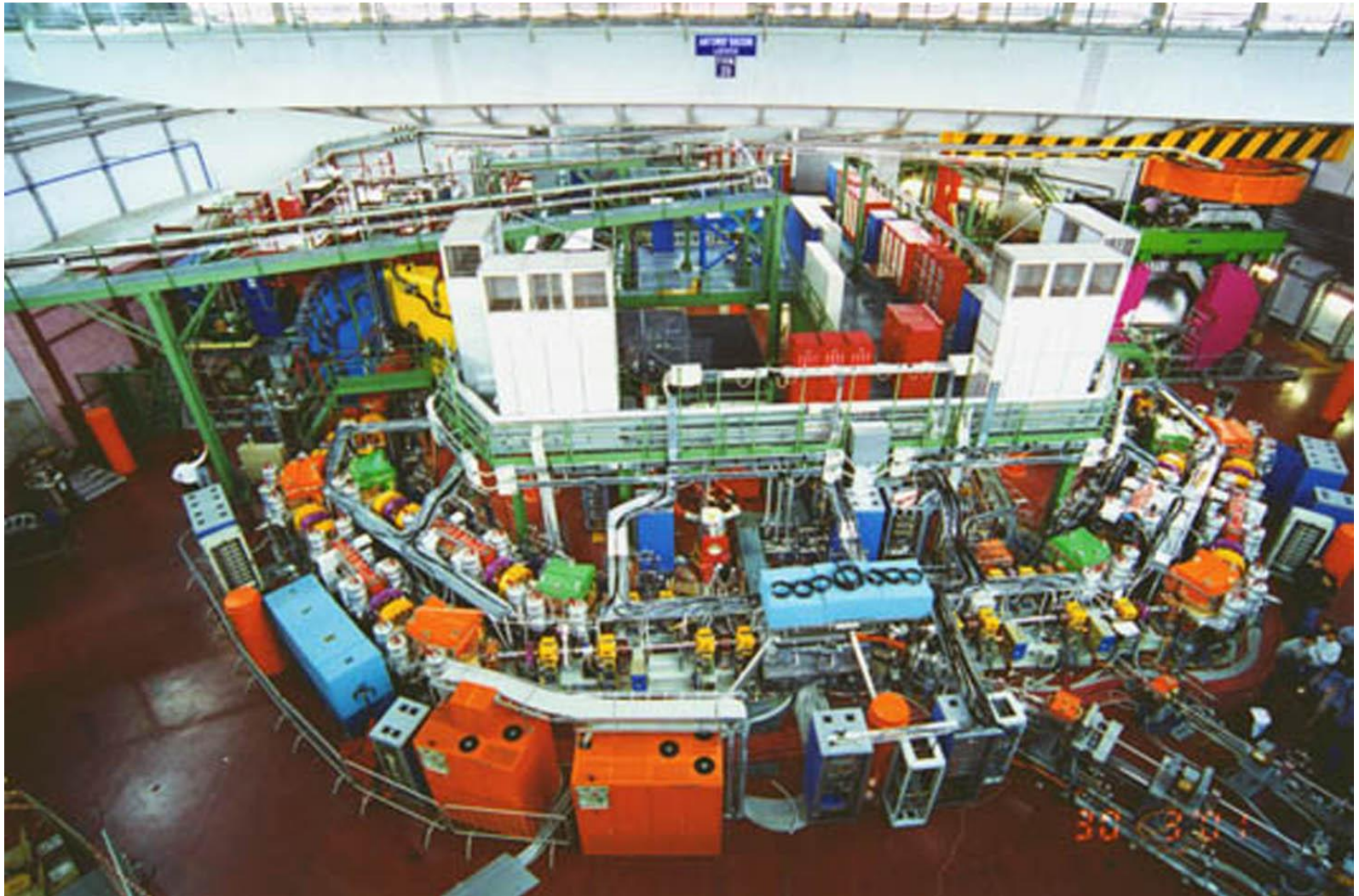

LNF

DAFNE-light

LINAC

DAFNE

BTF

SPARC

FLAME



LNF-INFN

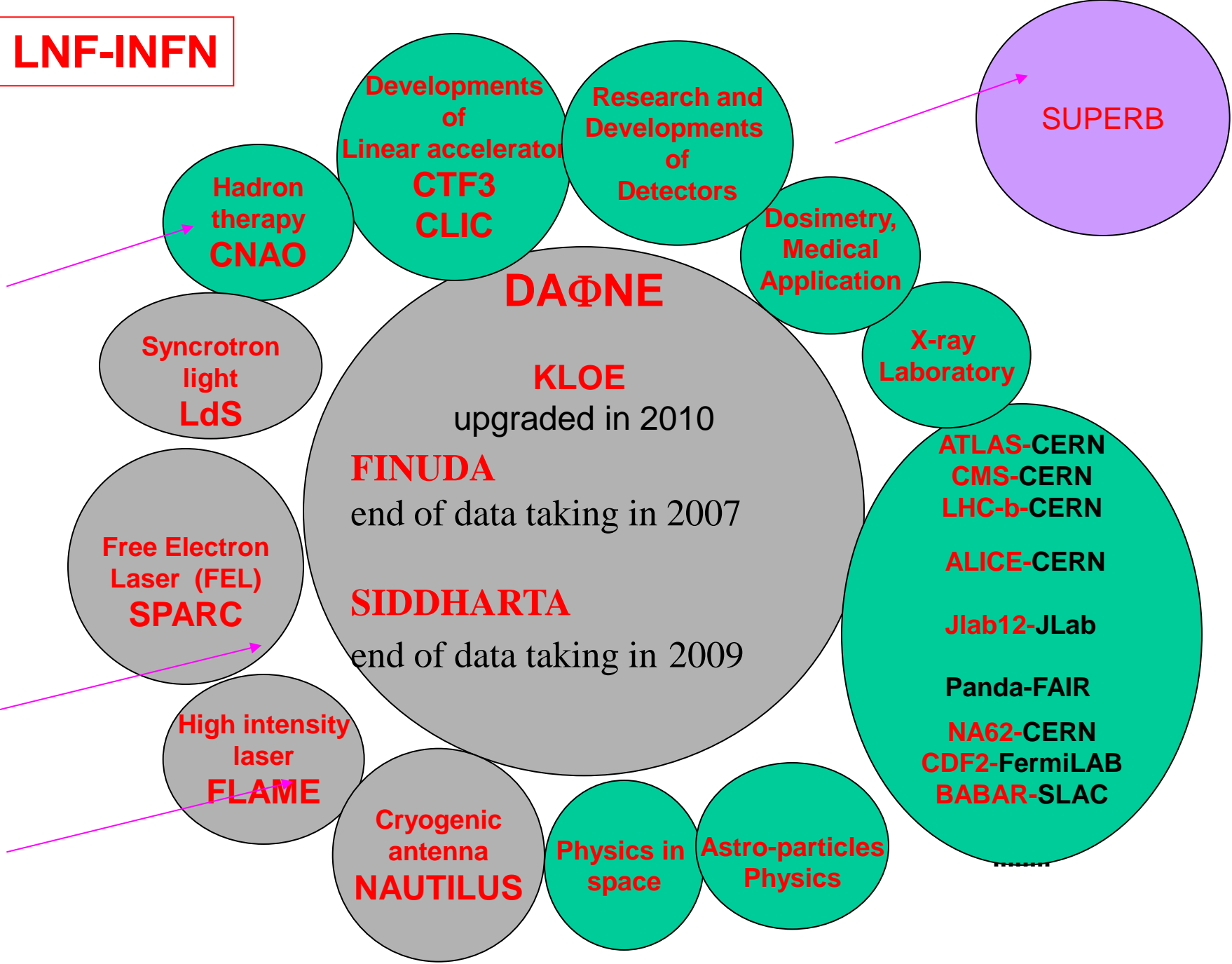

The Frascati Φ -Factory

Abundant production of Φ particles coming from the annihilation of electrons and positrons at the energy of the Φ - resonance.

	DAΦNE upgrade SIDDHARTA Crab Waist collision scheme	DAΦNE KLOE	DAΦNE FINUDA
L_{peak} [cm ² s ⁻¹]	4.53·10³² (5.0·10³²)	1.5·10 ³²	1.6·10 ³²
L_{day} [pb ⁻¹]	14.98	9.8	9.4
$L_{\text{1 hour}}$ [pb ⁻¹]	1.033	0.44	0.5

Synchrotron light from DAFNE

LNF are part of the European Infrastructure for synchrotron light

UV 2 - 10 eV
X-ray 900 - 3000 eV
IR 1.24 meV - 1.24 eV



FINUDA

Hypernuclear Physics (and more) at DAΦNE e^+e^- collider



K^\pm slow ~ 16 MeV and emitted
(almost) back-to-back

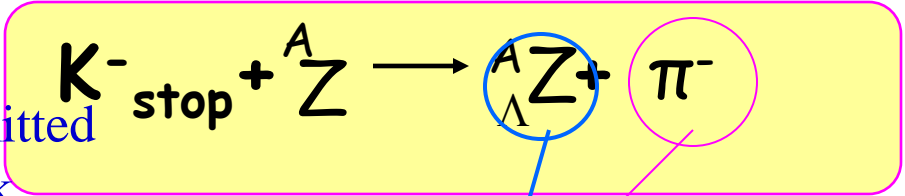

- Λ HYPERNUCLEI SPECTROSCOPY
essential tool for testing :
 - theoretical models of Λ -N potentials
 - single particle nuclear model predictions
 - bound states with strangeness

SIMULTANEOUSLY

and

- HYPERNUCLEAR DECAYS
 - study of baryon-baryon weak processes in nuclear matter: $\Lambda \rightarrow \pi N$ and $\Lambda N \rightarrow NN$ and $\Lambda(NN) \rightarrow NNN$
 - Neutron-rich hypernuclei

ON DIFFERENT NUCLEI

and, moreover:

- SEARCH FOR:
 - \bar{K} - multi-nucleon absorption
 - Deeply bound kaonic nuclei

FINUDA hypernuclear spectroscopy results

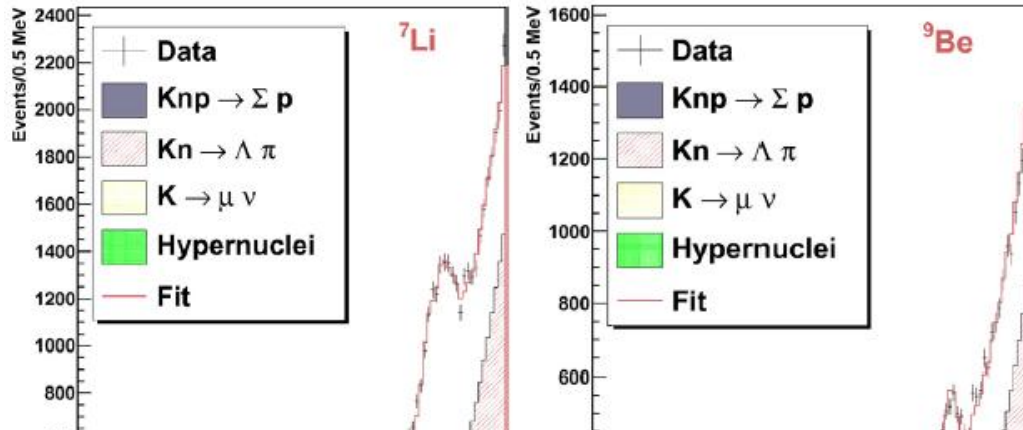

⁷ Li	B_{Δ} (MeV)	E_x (MeV)	Formation probability per stopped K^- (10^{-3})
1	5.8 ± 0.4	-	$0.37 \pm 0.04 \pm 0.05$
2	4.1 ± 0.4	1.7	$0.46 \pm 0.05 \pm 0.06$
3	2.6 ± 0.4	3.2	$0.21 \pm 0.03 \pm 0.03$

⁹ Be	B_{Δ} (MeV)	E_x (MeV)	Formation probability per stopped K^- (10^{-3})
1	6.2 ± 0.4	-	$0.16 \pm 0.02 \pm 0.02$
2	3.7 ± 0.4	2.5	$0.21 \pm 0.02 \pm 0.03$

¹³ C	B_{Δ} (MeV)	E_x (MeV)	Formation probability per stopped K^- (10^{-3})
1	11.0 ± 0.4	-	$0.10 \pm 0.02 \pm 0.01$

A. Feliciello's Talk

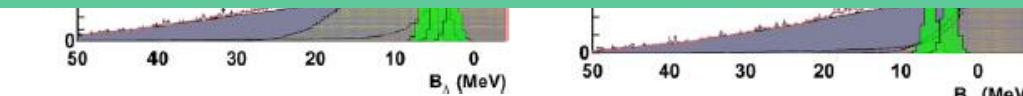

¹⁶ O	B_{Δ} (MeV)	E_x (MeV)	Formation probability per stopped K^- (10^{-3})
1	13.4 ± 0.4	-	$0.10 \pm 0.02 \pm 0.01$
2	7.1 ± 0.4	6.3	$0.26 \pm 0.04 \pm 0.04$
3	4.3 ± 0.4	9.1	$0.13 \pm 0.03 \pm 0.02$
4	2.4 ± 0.4	11.0	$0.15 \pm 0.03 \pm 0.02$
5	-3.3 ± 0.4	16.7	$0.55 \pm 0.07 \pm 0.08$
6	-4.7 ± 0.4	18.1	$0.28 \pm 0.06 \pm 0.04$

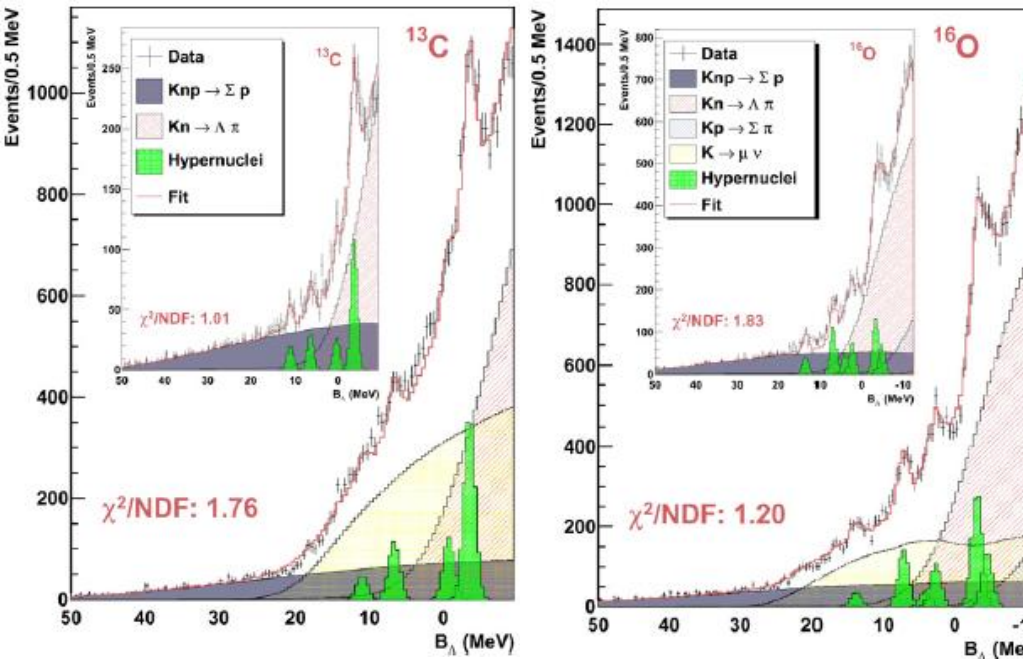

First measurements of the binding energies B_{Λ} and the formation probabilities of different hypernuclear states \rightarrow allowing a meaningful study of the mechanisms of formation of p-shell hypernuclei.

SIDDHARTA

Silicon Drift Detector for Hadronic Atom Research by Timing Applications

The determination of the *isospin dependent*
 $\bar{K}N$ scattering lengths through a

precision measurement of the shift
and of the width
(induced by the strong interaction)

of the K_{α} line of **kaonic hydrogen** and

the *first measurement* of **kaonic deuterium**

DAΦNE : Suitable for low-energy kaon physics
kaonic atoms

Kaon-nucleons/nuclei interaction studies

Less hadronic background due to the beam

WINNING CARD OF SIDDHARTA:

Fast (triggerable) spectroscopic SDD-detectors

2 array of 3 cm² SDD



144 SDDs used by SIDDHARTA

C. Curceanu's Talk

SIDDHARTA measurements in 2009:

- Kaonic Hydrogen: 400 pb⁻¹
 - Most precise measurement in the world
 - Phys. Lett. B 704 (2011) 113, Nucl. Phys. A. (2012)
- Kaonic helium 4: 30 pb⁻¹
 - first measurement in the world in gs
 - Phys. Lett. B 681 (2009) 310
- Kaonic helium 3: 10 pb⁻¹
 - first measurement in the world
 - Phys. Lett. B 697 (2011) 199
- Kaonic deuterium 100 pb⁻¹,
 - first exploratory measurement, small signal, significance ~ 2σ, paper in preparation.

SIDDHARTA-2: Kaonic deuterium and other types of exotic atoms

panda experiment at FAIR

Facility for Antiproton and Ion Research



Antiproton production

- Proton Linac 70 MeV
- Accelerate p in SIS18 / 100
- Produce p on Cu target
- Collection in CR, fast cooling
- Accumulation in RESR
- Storage and usage in HESR

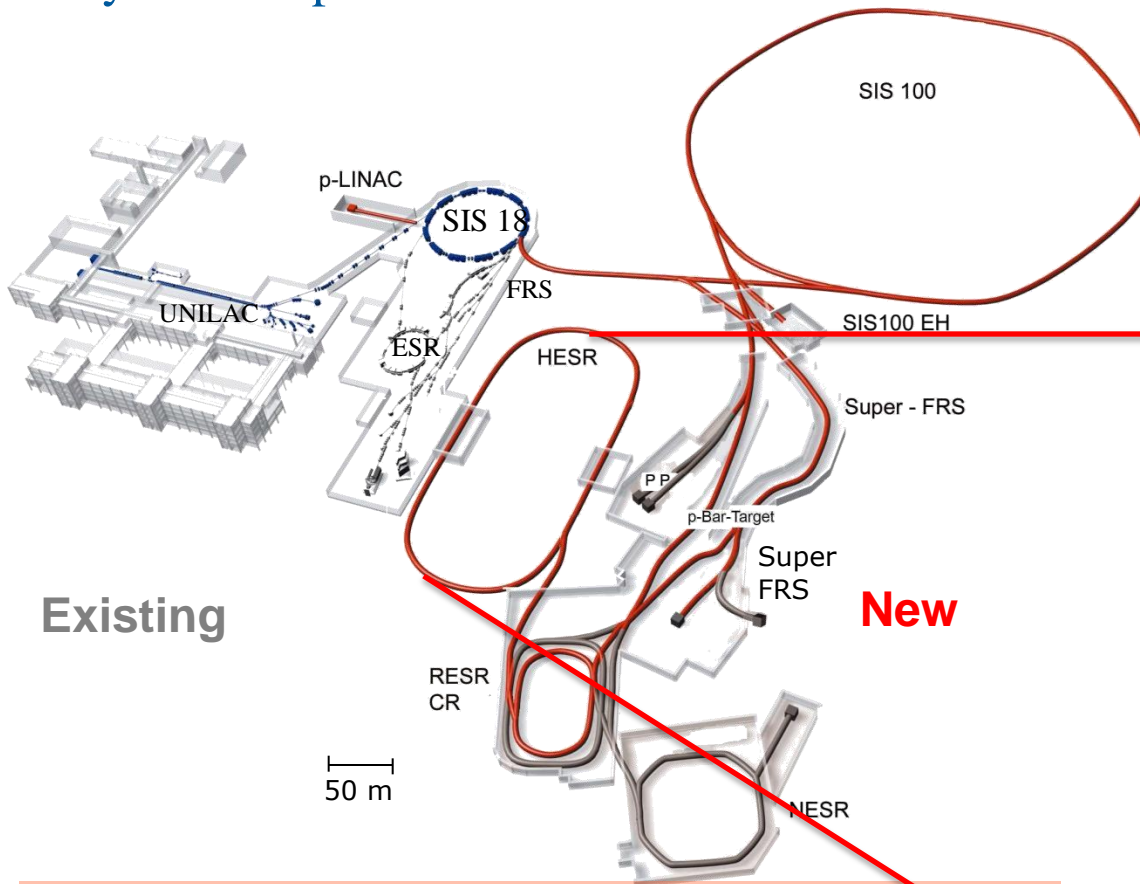

Existing

New

HESR: Storage ring for p

- Injection of p at 3.7 GeV/c
- Slow synchrotron (1.5-15 GeV/c)
- Luminosity up to $L \sim 2 \times 10^{32} \text{ cm}^{-2} \text{ s}^{-1}$
- Beam cooling (stochastic & electron)

Paola Gianotti

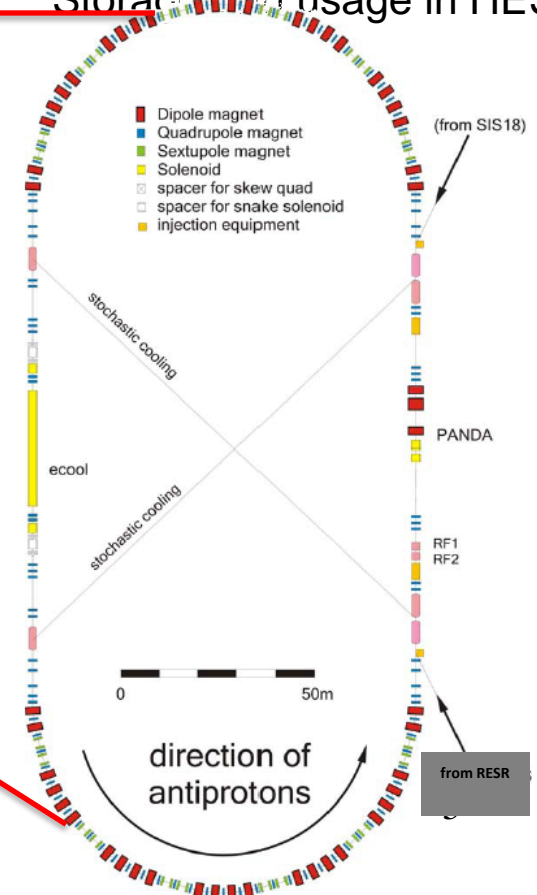

FAIR Timeline

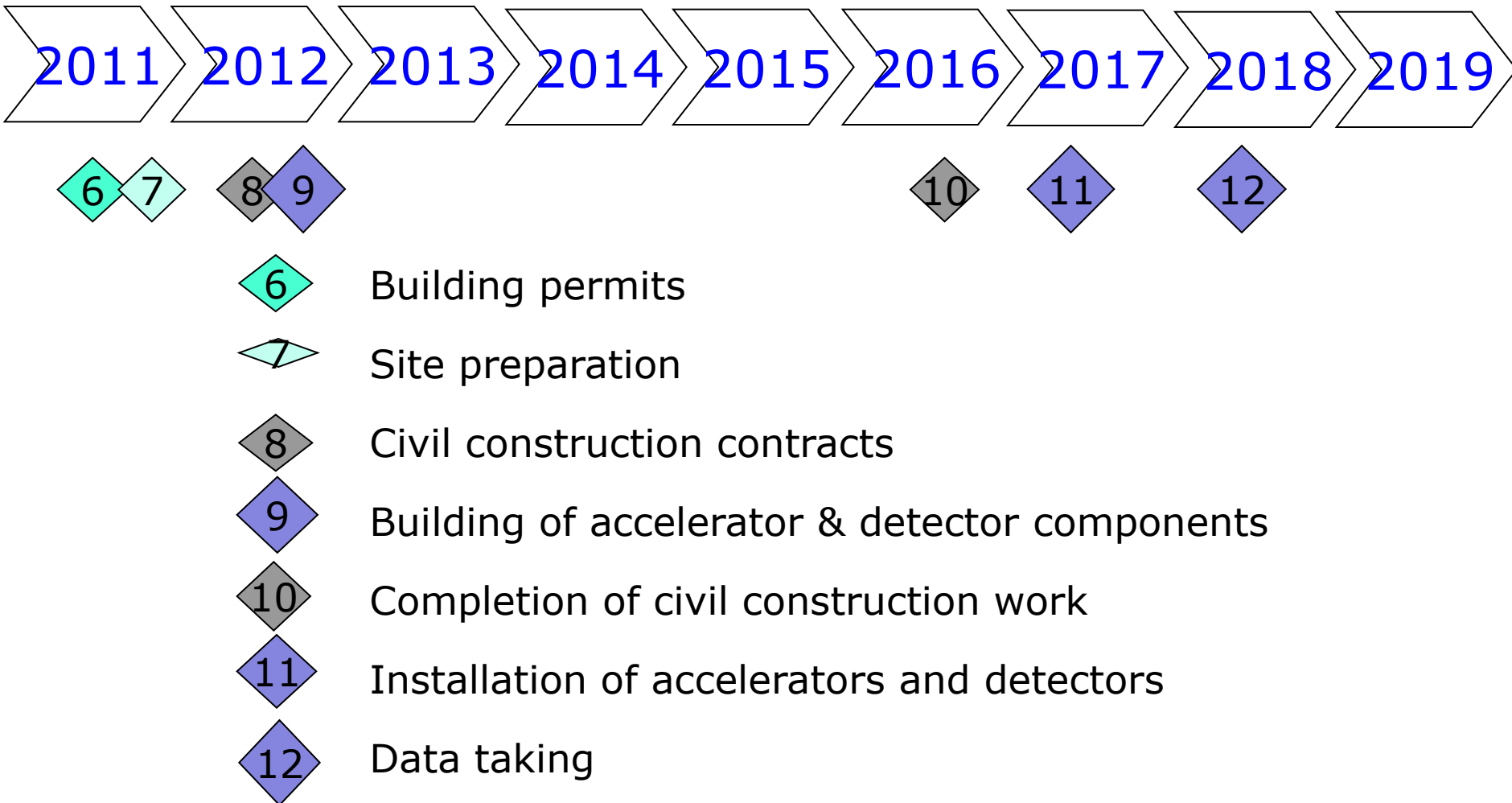

Italy is not a FAIR shareholder.

Around 60 INFN involved in the PANDA experiment

Paola Gianotti



Scientific program



• Meson spectroscopy

- light mesons
- charmonium
- exotic states
 - ✓ glueballs
 - ✓ hybrids
 - ✓ molecules/multiquarks
- open charm

• Baryon/antibaryon production

• Charm in nuclei

• Hypernuclei

• Em. form factors of the proton

p Momentum [GeV/c]
0 2 4 6 8 10 12 15

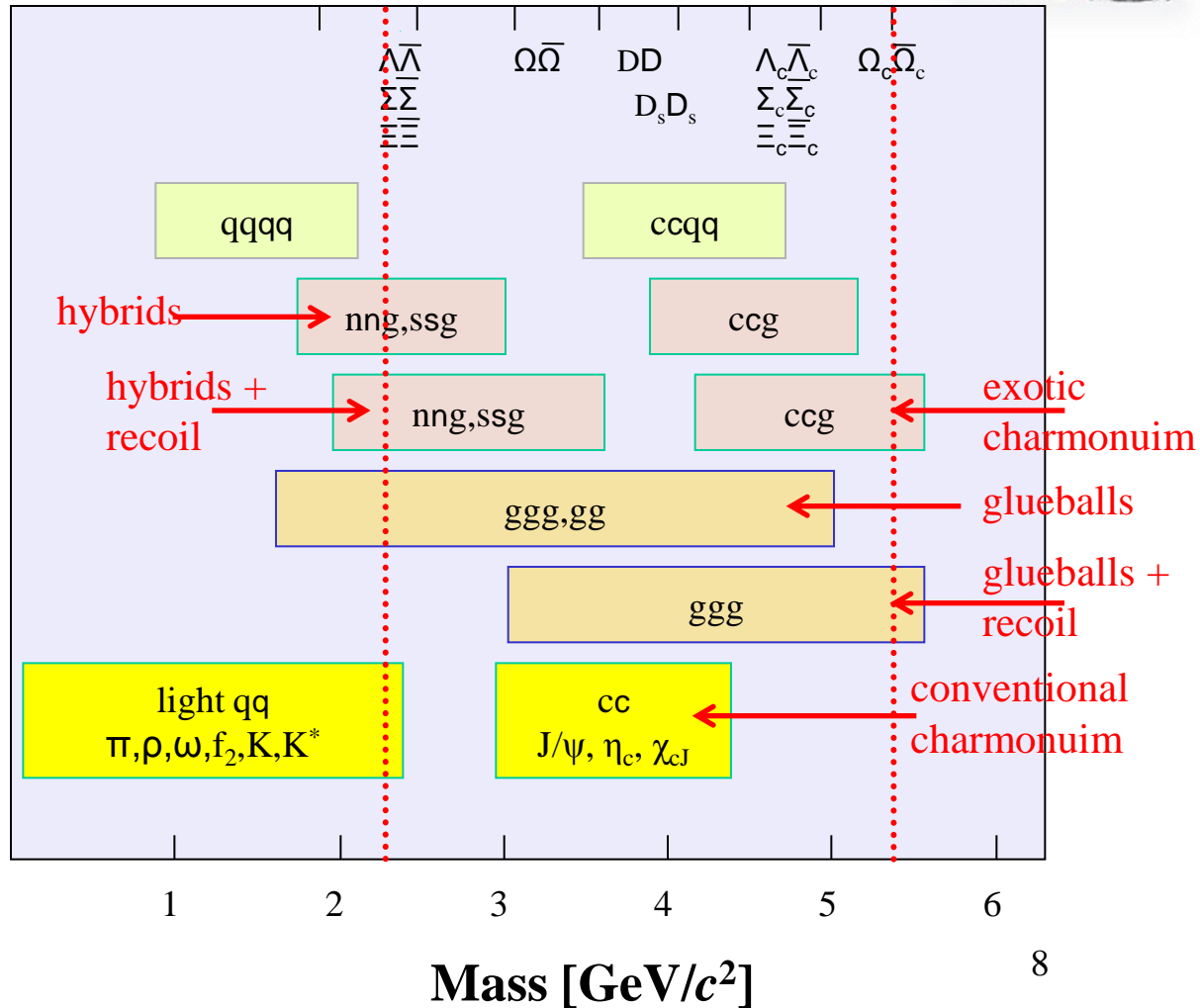

Doubly strange systems

($S = \pm 2$) hyperon – antihyperon systems are fully accessible at PANDA

Exotic hyperatom:

Ξ^- occupies an atomic level

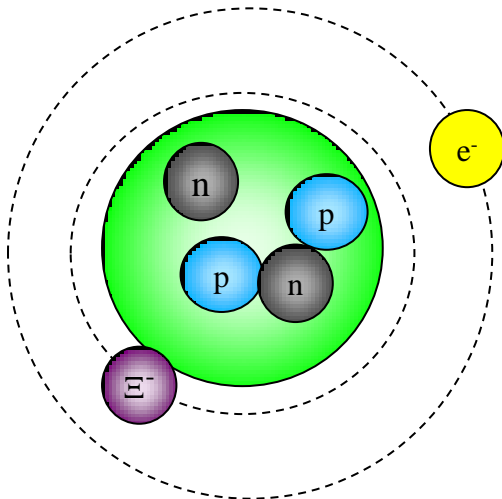

Ξ^- -nucleus interaction

- Atomic orbits overlap nucleus
- Strong interaction and Coulomb force interplay
- Lowest atomic levels are shifted and broadened
- Potential: Coulomb + optical

Double Λ Hypernucleus:

2 Λ 's replace 2 nucleons in a nucleus

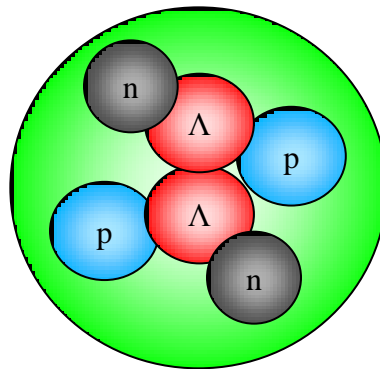

Doubly Strange Hypernucleus:

Ξ^- occupies a nuclear level

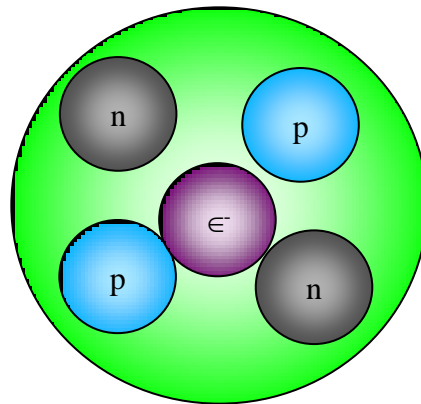

$\Lambda\Lambda$ strong interaction

- only possible in double hypernuclei
- YY potential: attractive/repulsive?
- hyperfragments probability dependence on YY potential

One Boson Exchange features

$\Lambda\Lambda \rightarrow \Lambda\Lambda$: only non strange, $I = 0$ meson exchange (ω, η, \dots)

$\Lambda\Lambda$ weak interaction: hyperon induced decay:

- $\Lambda\Lambda \rightarrow \Lambda n$: $\Gamma_{\Lambda n} \ll \Gamma_{\text{free}}$ (expected)
- $\Lambda\Lambda \rightarrow \Sigma^+ p$: $\Gamma_{\Sigma^+ p} \ll \Gamma_{\text{free}}$ (expected)

Ξ^- -N interaction:

- short range interaction
- long range interaction
-

$\Lambda\Lambda$ Hypernuclei

Status of the art:

Nucleus	$B_{\Lambda\Lambda}(\Lambda\Lambda^{AZ})$ [MeV]	$\Delta B_{\Lambda\Lambda}(\Lambda\Lambda^{AZ})$ [MeV]	Reference	Reaction
${}_{\Lambda\Lambda}^{10}\text{Be}$	17.7 ± 0.4	4.3 ± 0.4	M.Danysz et al., PRL.11(1963) 29	$K^- + A \rightarrow K^+ + \Xi^-$
${}_{\Lambda\Lambda}^6\text{He}$	10.9 ± 0.5	4.6 ± 0.5	D.J.Prowse, PRL.17(1966) 782	$K^- + A \rightarrow K^+ + \Xi^-$
${}_{\Lambda\Lambda}^{10}\text{Be}$	8.5 ± 0.7	-4.9 ± 0.7	KEK-E176	$K^- + p \rightarrow K^+ + \Xi^-$ (q.f)
${}_{\Lambda\Lambda}^{13}\text{B}$	27.6 ± 0.7	4.9 ± 0.7	S.Aoki et al., PTP.85(1991) 1287	$K^- + p \rightarrow K^+ + \Xi^-$ (q.f)
${}_{\Lambda\Lambda}^{12}\text{B}$		4.5 ± 0.5	P.Khaustov et al., PRC.61(2000)027601	$({}^{12}\text{C})_{\text{atom}} \Xi^- \rightarrow {}^{12}\text{B}_{\Lambda\Lambda} + n$
${}_{\Lambda\Lambda}^6\text{He}$	7.25 ± 0.19 <small>+0.18 -0.11</small>	1.01 ± 0.2 <small>+0.18 -0.11</small>	KEK-E373,NAGARA H.Takahashi et al., PRL.87(2001)212502-1	$K^- + p \rightarrow K^+ + \Xi^-$ (q.f)
${}_{\Lambda\Lambda}^{12}\text{B}$		$\sigma(\theta < 8^\circ) \approx 6\text{-}10\text{nb}$	K.Yamamoto et al., PLB.478(2000) 401	$K^- + {}^{12}\text{C} \rightarrow K^+ + {}^{12}\text{B}_{\Lambda\Lambda}$

Up to know these systems have been studied in cosmic rays or using kaon-beams:



KEK, BNL-AGS, have demonstrated that the systems are produced.

At JPARC with high intensity kaon-beams the goal is to stop $10^4 \Xi^-$ in a nuclear target.

At PANDA the same amount of data will be collected, with the possibility to run with different nuclear targets at the same time.

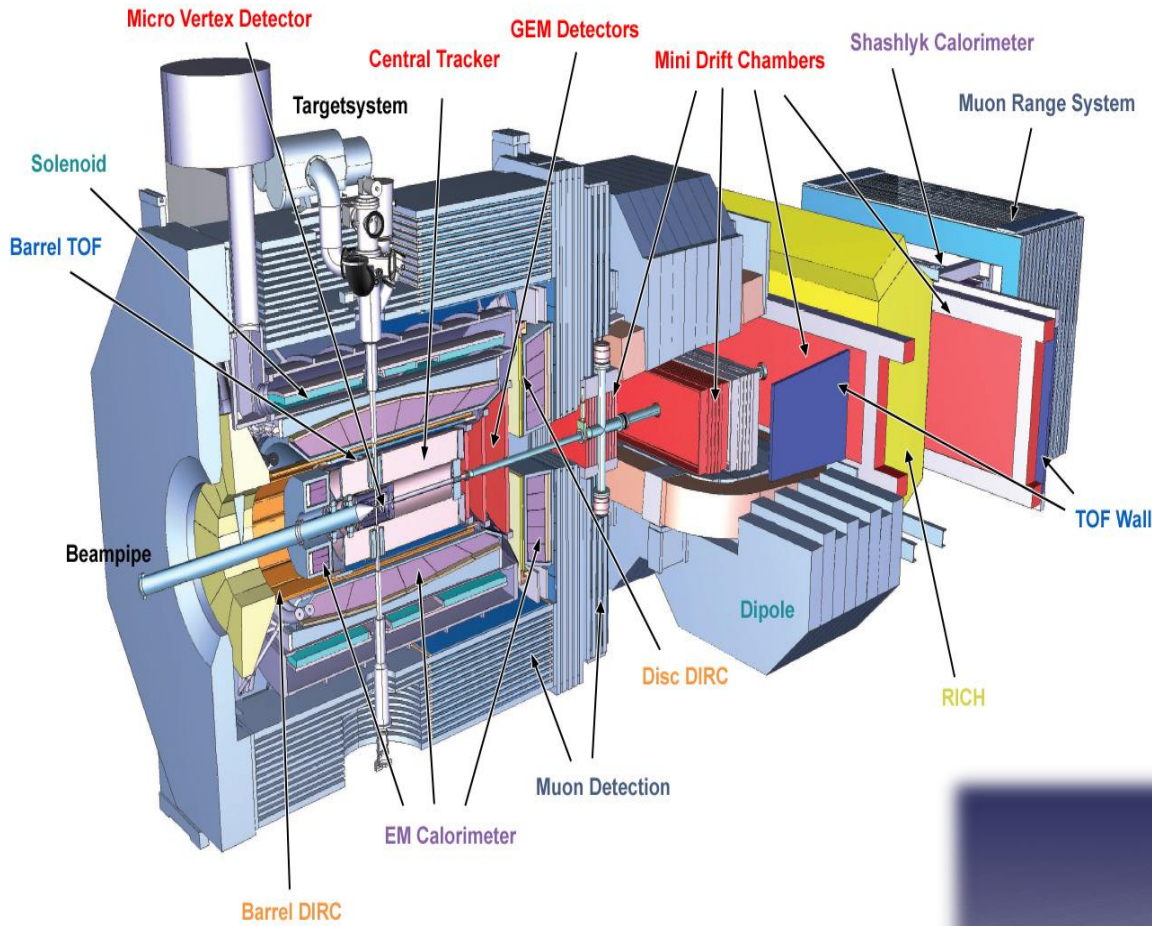

Straw Tube Central tracker

LNF-INFN
 Ferrara INFN and Uni.
 Pavia INFN and Univ.

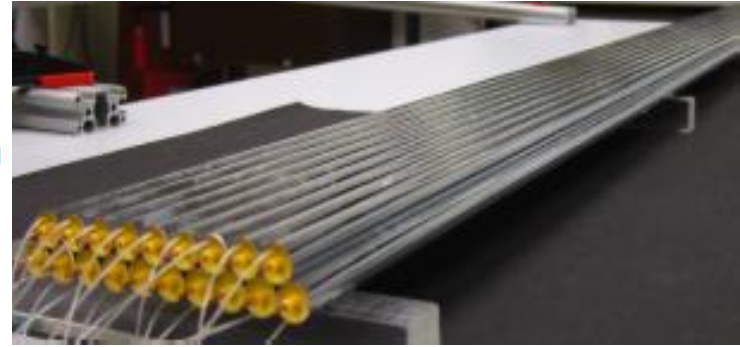

- **STRAW SUPPORT FRAME**
 prototype by LNF
- **AUXILIARY INSERTION
 STRUCTURE**
 by LNF

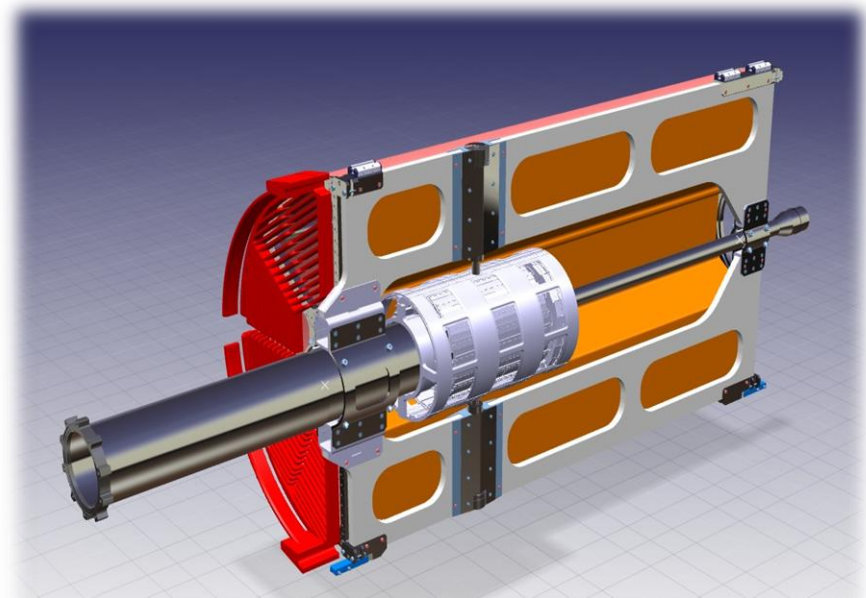

The JLAB12 Italian Collaboration

JLab is a laboratory for QCD studies from quarks to nuclei

- nucleon's partonic distribution functions
- form factors
- baryon and meson spectroscopy
- nuclear effects and nuclear structure
- physics beyond the Standard Model

• 12 GeV upgrade

- up to 12 GeV e^- beam
- upgrade of the existing Halls
- new Hall D
- transition already underway
- start of commissioning end of 2013
- start of physics ops. end of 2014

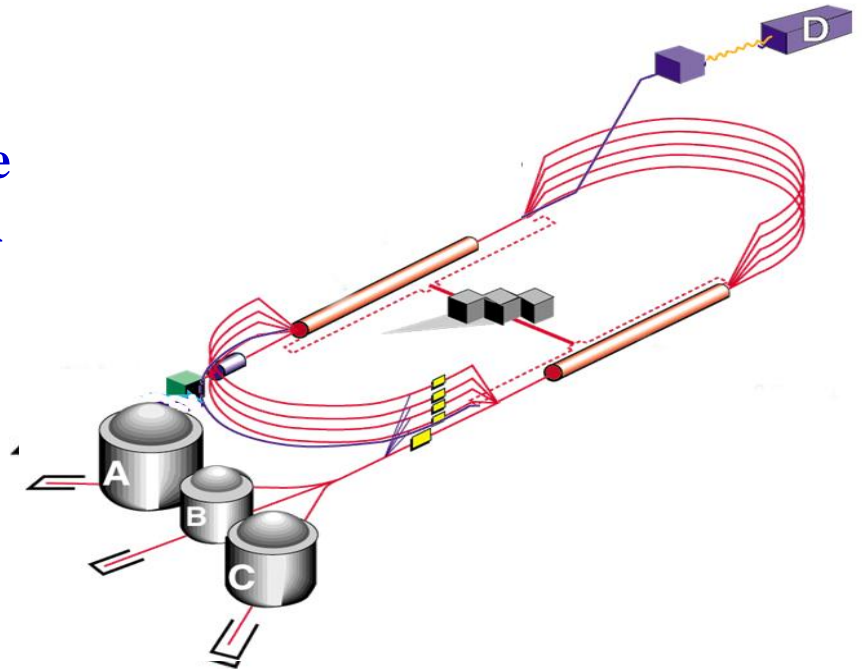

- The LNF is involved since the beginning in Hall A, B
- JLAB12 is the Italian Collaboration born in 2009
- It includes more than 70 experimental and theoretical physicists and 30 technicians from about 15 INFN sections

Physics activity of the LNF group

Main goal: the study of the internal structure of the nucleon

Physics observables: Transverse Momentum Dependent parton distribution functions (TMDs)

Tool: Semi-Inclusive Deep Inelastic Scattering experiments

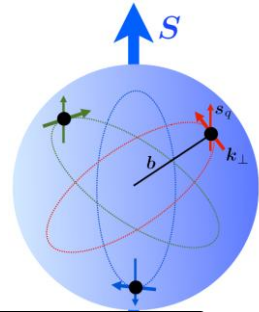

TMDs are the 3D generalization of DIS collinear PDFs

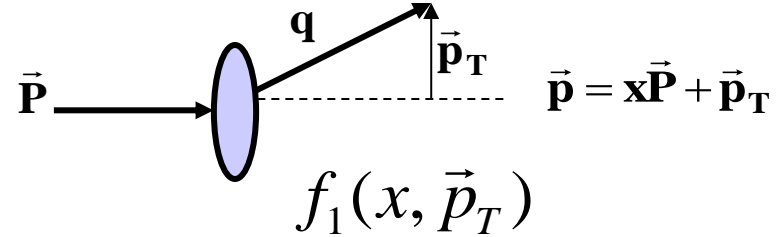
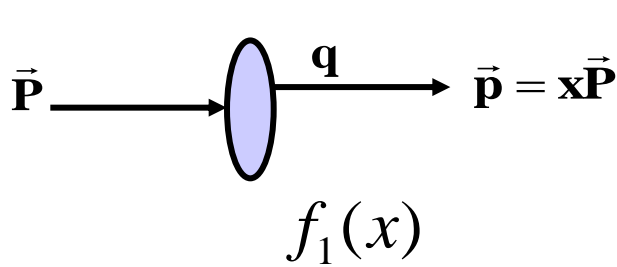

quark polarisation

N/q	U	L	T
U	f_1 Number Density		h_1^\perp Boer-Mulders
L		g_1 Helicity	h_{1L}^\perp Worm-gear
T	f_{1T}^\perp Sivers	g_{1T}^\perp Worm-gear	h_1 Transversity h_{1T}^\perp Pretzelosity

nucleon polarisation

TMDs in SIDIS

$$\vec{e}\vec{p} \rightarrow e' h X$$

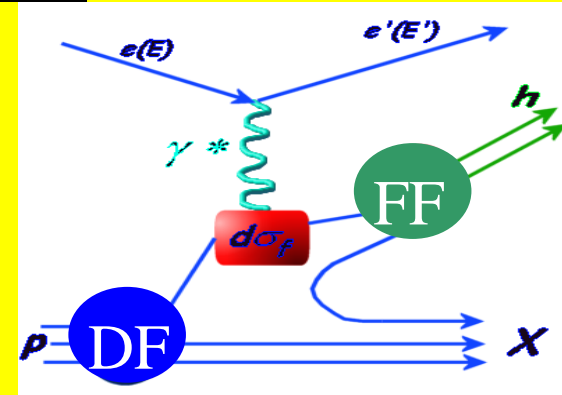

$$d\sigma \propto \sum DF(x, p_T) \otimes d\sigma^{eq} \otimes FF(z, k_T)$$

Accessing TMDs in SIDIS

Spin
asymmetries

$$A \propto \frac{N^+ - N^-}{N^+ + N^-} \propto \frac{PDF \otimes FF}{f_1 \otimes D_1} \left. \vphantom{\frac{N^+ - N^-}{N^+ + N^-}} \right\} \underline{\text{convolutions of TMDs}}$$

Double beam and target
spin asymmetry

$$A_{LL} \propto \frac{g_1}{f_1}$$

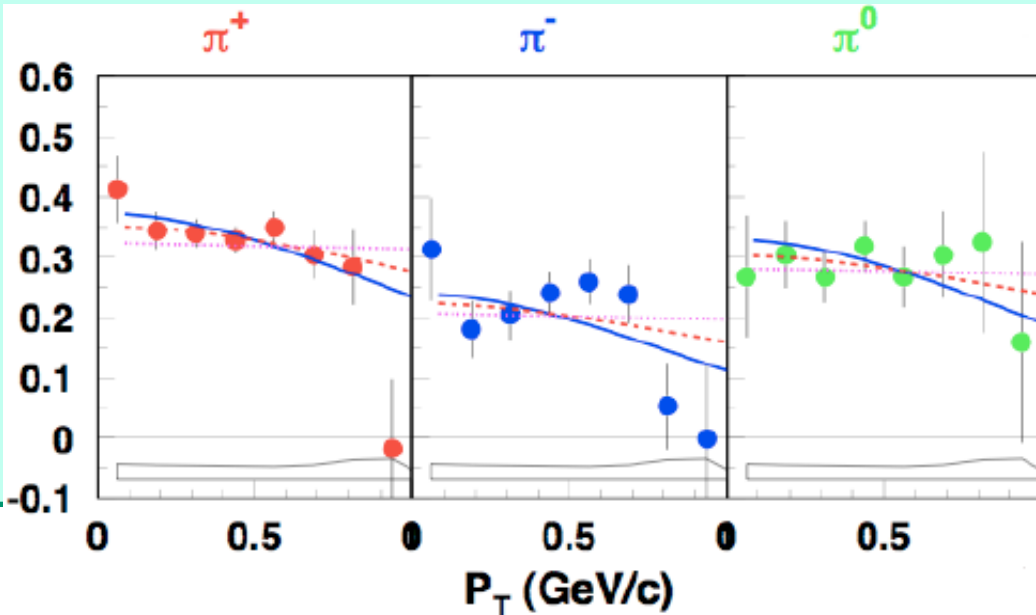

Fits of data give different transverse
momentum dependence for f_1 and g_1

Single beam spin asymmetry $A_{LU}^{\sin \phi_h}$

π^0

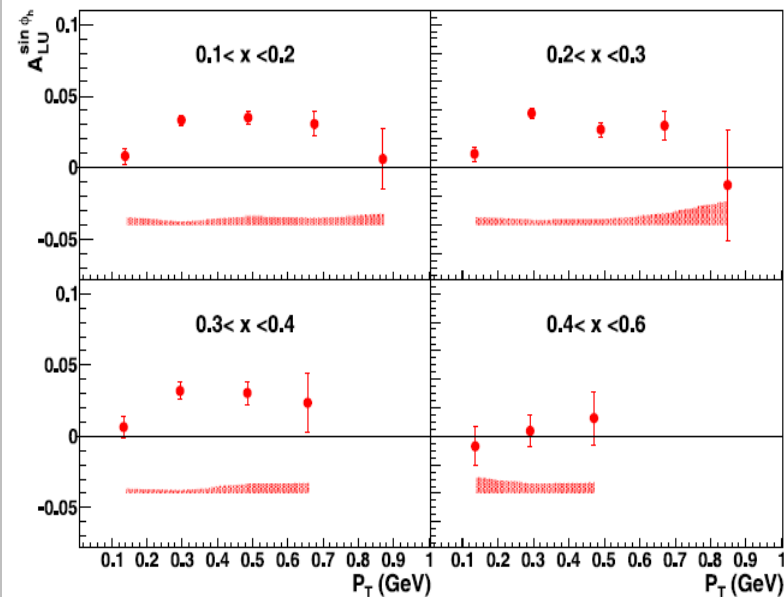

High statistics allows
multidimensional analysis

LNF plans for the 12 GeV

Approved experiments in Hall B for the first 5 years of the 12 GeV data taking

Proposal	Physics	Contact	Rating	Days	Group	New equipment	Energy	Group	Target
E12-06-108	Hard exclusive electro-production of π^0, η	P. Stoler	B	10		RICH	11	RG-A F. Sabatié	liquid H_2
E12-06-112	Proton's quark dynamics in SIDIS pion production	H. Avakian	A	10		IC Forward tagger			
E12-06-119	Deeply Virtual Compton Scattering	F. Sabatié	A	10					
E12-09-103	Excitation of nucleon resonances at high Q^2	M. Gothe	A	10					
E11-005	Hadron spectroscopy with forward tagger	M. Gothe	A	10					
PR12-11-103	DVMP of ρ, ω, ϕ	M. Gothe	A	10			11	RG-B K. Hafidi	liquid D_2 target
E12-07-104	Neutron magnetic form factor	M. Gothe	A	10					
PR12-11-109 (a)	Dihadron DIS production	M. Gothe	A	10					
E12-09-007a	Study of partonic distributions in SIDIS kaon production	M. Gothe	A	10					
E12-09-008	Boer-Mulders asymmetry in K SIDIS w/ H and D targets	M. Gothe	A	10					
E11-003	DVCS on neutron target	M. Gothe	A	10			11	RG-C S. Kuhn	NH_3 ND_3
E12-06-109	Longitudinal Spin Structure of the Nucleon	M. Gothe	A	10					
E12-06-119(b)	DVCS on longitudinally polarized proton target	M. Gothe	A	10					
E12-07-107	Spin-Orbit Correl. with Longitudinally polarized target	M. Gothe	A	10					
PR12-11-109 (b)	Dihadron studies on long. polarized target	M. Gothe	A	10					
E12-09-007(b)	Study of partonic distributions using pion production	M. Gothe	A	10			11	RG-D	Nuclear
E12-09-009	Spin-Orbit correlations in K production w/ pol. targets	H. Avakian	A	10					
E12-06-106	Color transparency in exclusive vector meson production	M. Gothe	A	10					
E12-06-117	Quark propagation and hadron formation	W. Brodeur	A	10					
E12-10-102	Free Neutron structure at large x	S. Buitman	A	10	40	Radia TPC			
PR12-11-109	SIDIS on transverse polarized target	M. Contallegro	A	2		Transverse target	11	RG-E	Nuclear
							11	RG-F	Gas D_2
							11	RG-G	HD

**Proposals with LNF
co-spokepersons**

**Measurements of
beam and/or target
spin asymmetries
in single or double
pion and kaon
SIDIS**

RICH detector for Hall B/CLAS12

CLAS12

- Kaon ID necessary for TMD flavor separation
- Rejection factor >1000 because of relative π/K production rate

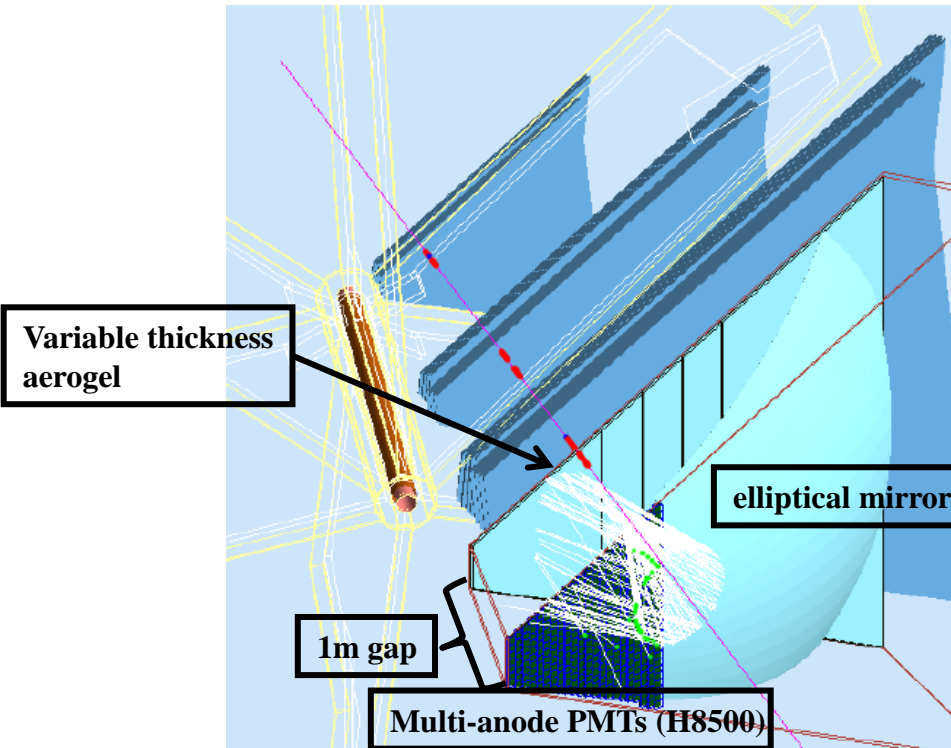
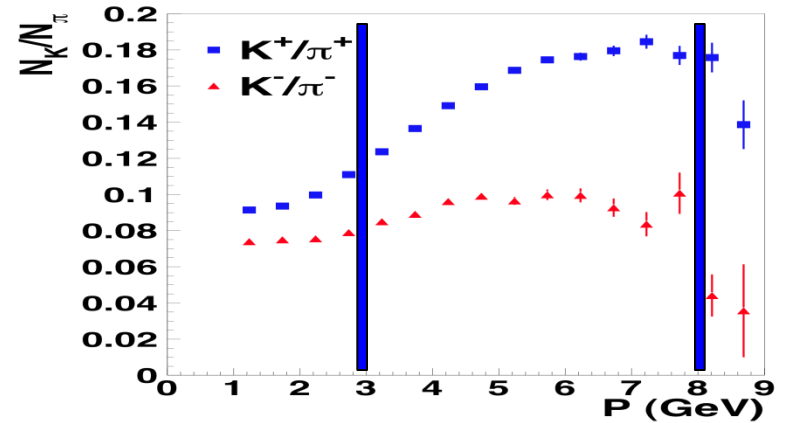
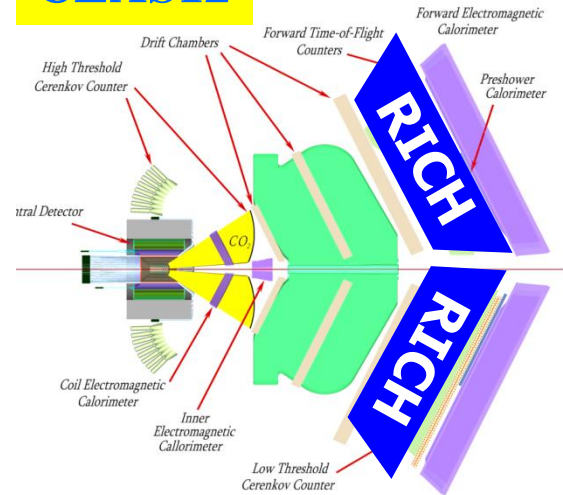

- Test of a prototype at CERN T9
August and November

pion ring
with 28 H8500
MA-PMTs
(preliminary)

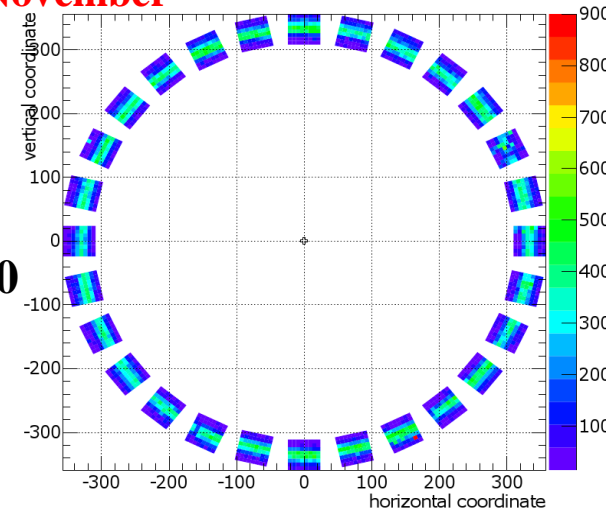

ALICE @ LNF : EM Calorimeter for jet quenching

Parton energy loss through medium induced gluon radiation makes the jet reconstruction and its quenching the golden channel to study the Quark Gluon Plasma

3 European Super-Modules:
end of installation Jan. 2011

- ‘Shashlik’ WLS fiber readout
- Granularity: 12.672 towers
 $\Delta\eta \times \Delta\phi \sim 0.014 \times 0.014$
- 4 towers grouped into module
- Super-Module = 24 strips of
12 modules each=288 modules
- 11 Super-Modules in total
 $\Delta\Phi = 110^\circ$
 $-0.7 < \eta < 0.7$

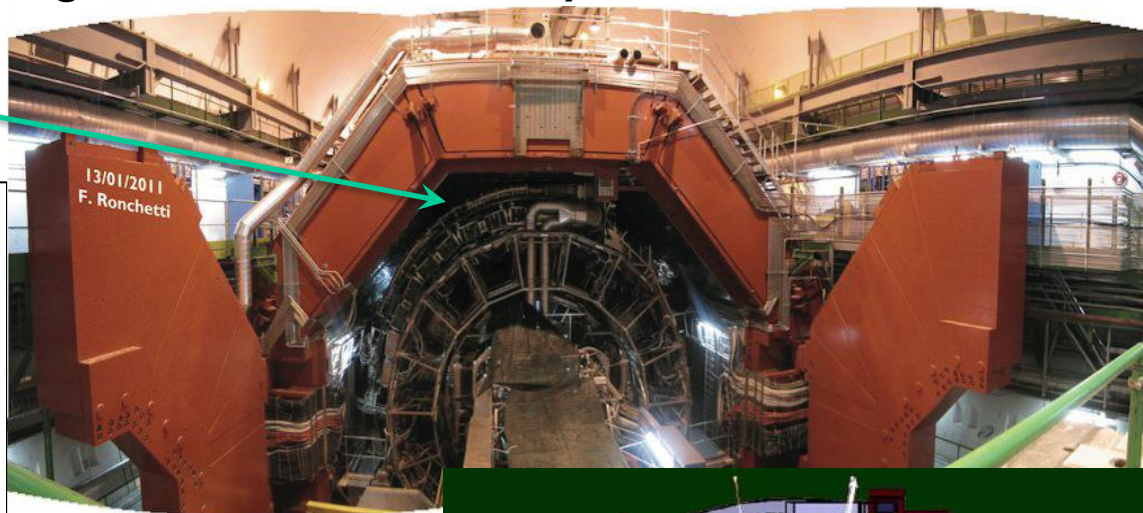

R. Nania's Talk

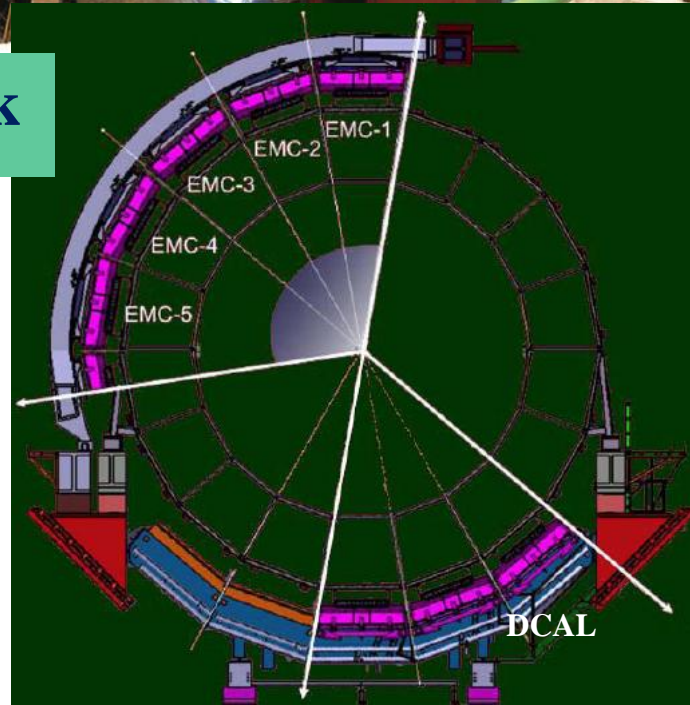

Study of Strongly Interacting Matter



JRA18

Di- JETCal: e.m. Calorimeter for
Quenching Study by jet, di-jet, γ -jet

Basic Unit = 4 channels

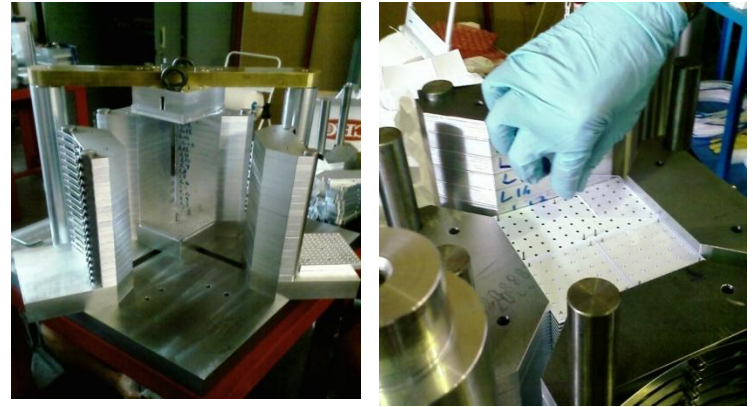

Assembling station (2 on site)

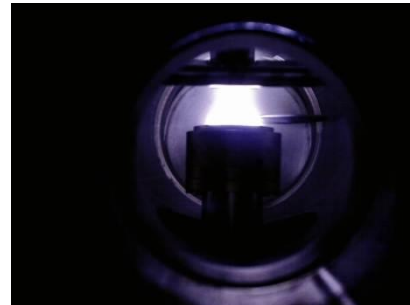

Aluminization of
200k fibers (WLS)

Jet measurements

Jet in EMCal
triggered by the
HighLevel
Trigger

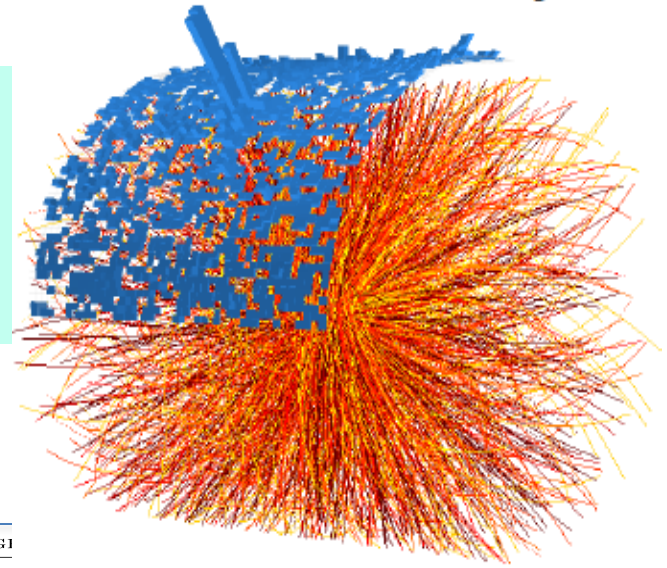

PUBLISHED FOR SISSA BY SPRINGER

RECEIVED: January 11, 2012

ACCEPTED: February 20, 2012

PUBLISHED: March 16, 2012

Measurement of event background fluctuations for charged particle jet reconstruction in Pb-Pb collisions at $\sqrt{s_{NN}} = 2.76$ TeV

LNF first author

EUROPEAN ORGANIZATION FOR NUCLEAR RESEARCH



CERN-PH-EP-To be specified
To be specified

Inclusive jet spectrum in PbPb collisions at $\sqrt{s_{NN}} = 2.76$ TeV

*LNF Co-first author
In preparation*

EUROPEAN ORGANIZATION FOR NUCLEAR RESEARCH



CERN-PH-EP-To be specified
To be specified

Jet structure in PbPb collisions at $\sqrt{s_{NN}} = 2.76$ TeV

*LNF first author
In preparation*

SPARC_LAB

Sources for Plasma Accelerators and Radiation Compton with Lasers And Beams

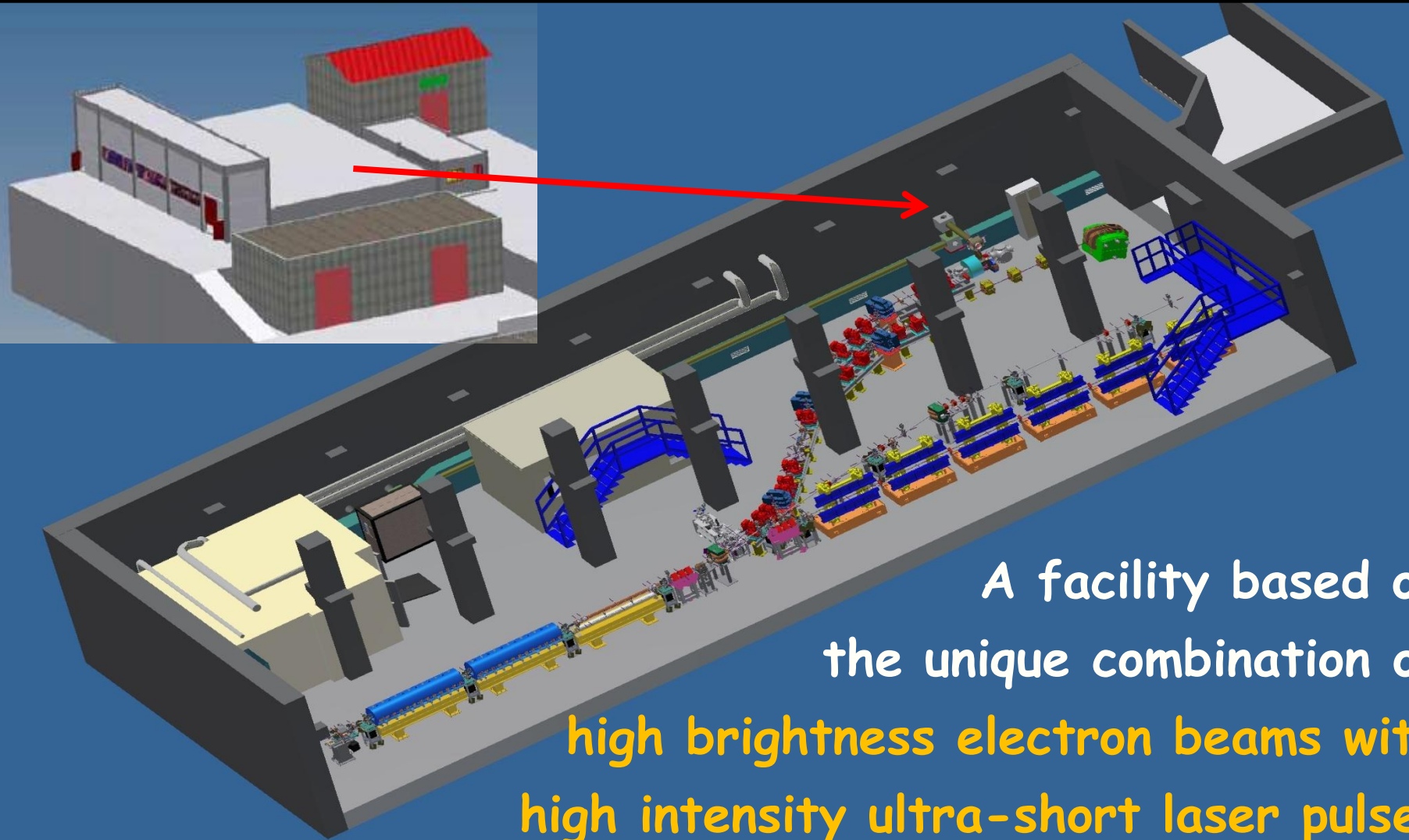

A facility based on
the unique combination of
high brightness electron beams with
high intensity ultra-short laser pulses

SPARC

11b 10b 9b 8b 7b 6b 5b 4b 3b 2b 1b

$\lambda_{\text{max}} = 2.2$
 $\lambda_r = 500$
nm

15
m

Long
Solenoids

S-band
Gun

Seeding

THz
Source

FLAME: Frascati Laser for Acceleration and Multidisciplinary Experiments



TRANSPORT
TO SPARC

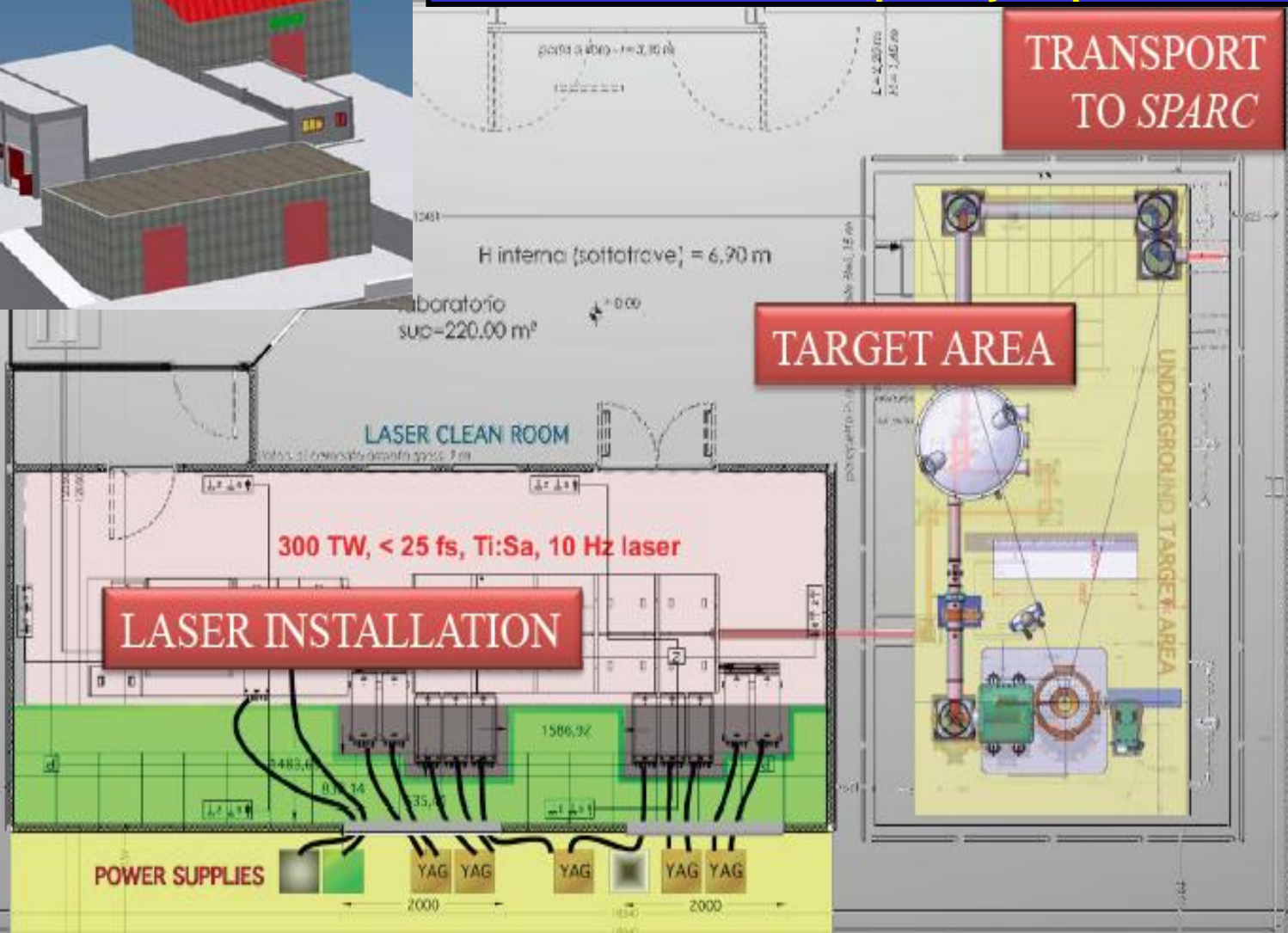

FLAME Laser, gas-jet target, beam transport fully commissioned in **2011**.
- **250 TW** achieved.
- **Beam focused into gas cell** for plasma acceleration.

Electron energies between 200 and 250 MeV were achieved in the self-injection mode.

The best laser-plasma acceleration results achieved worldwide

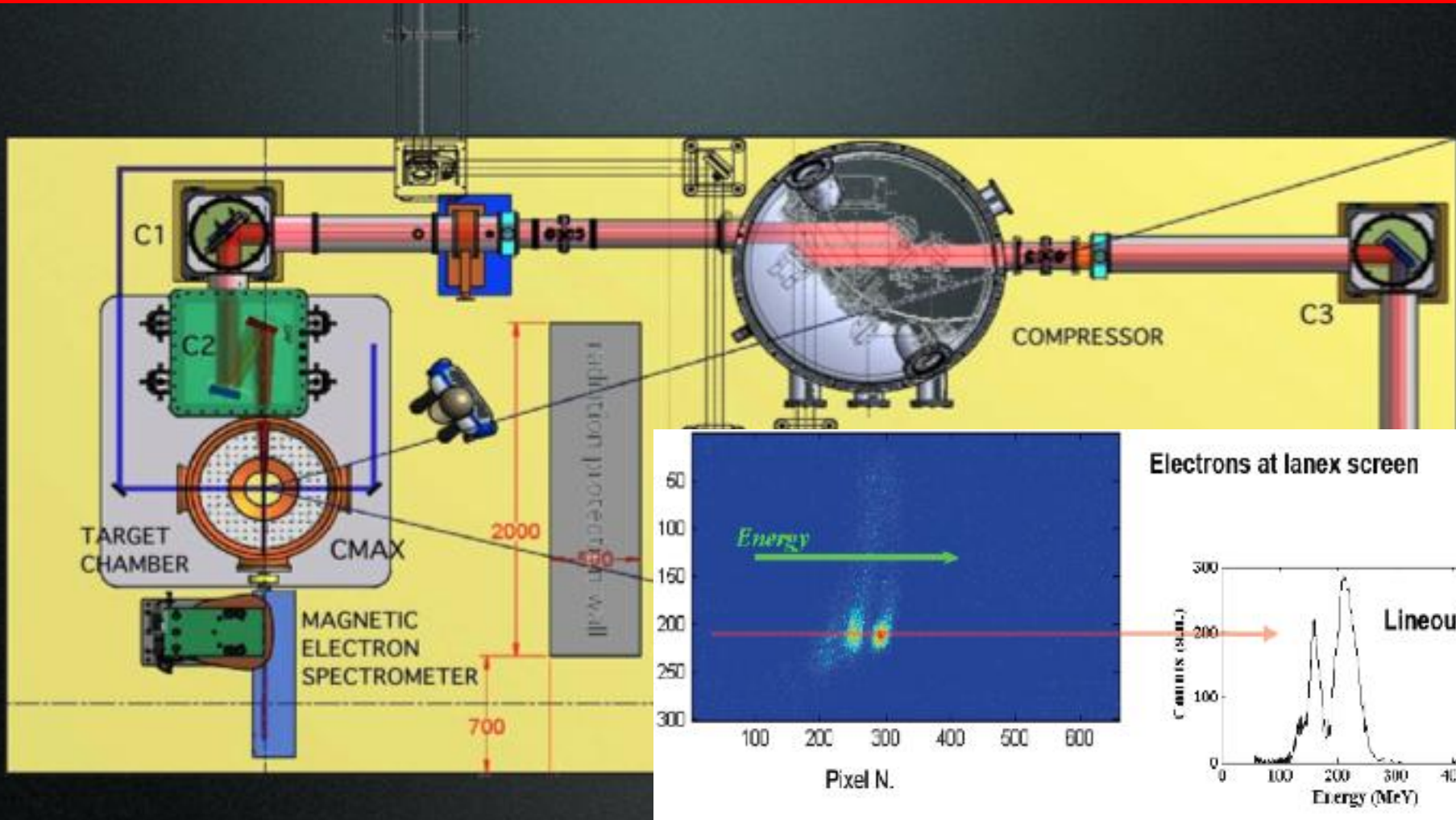

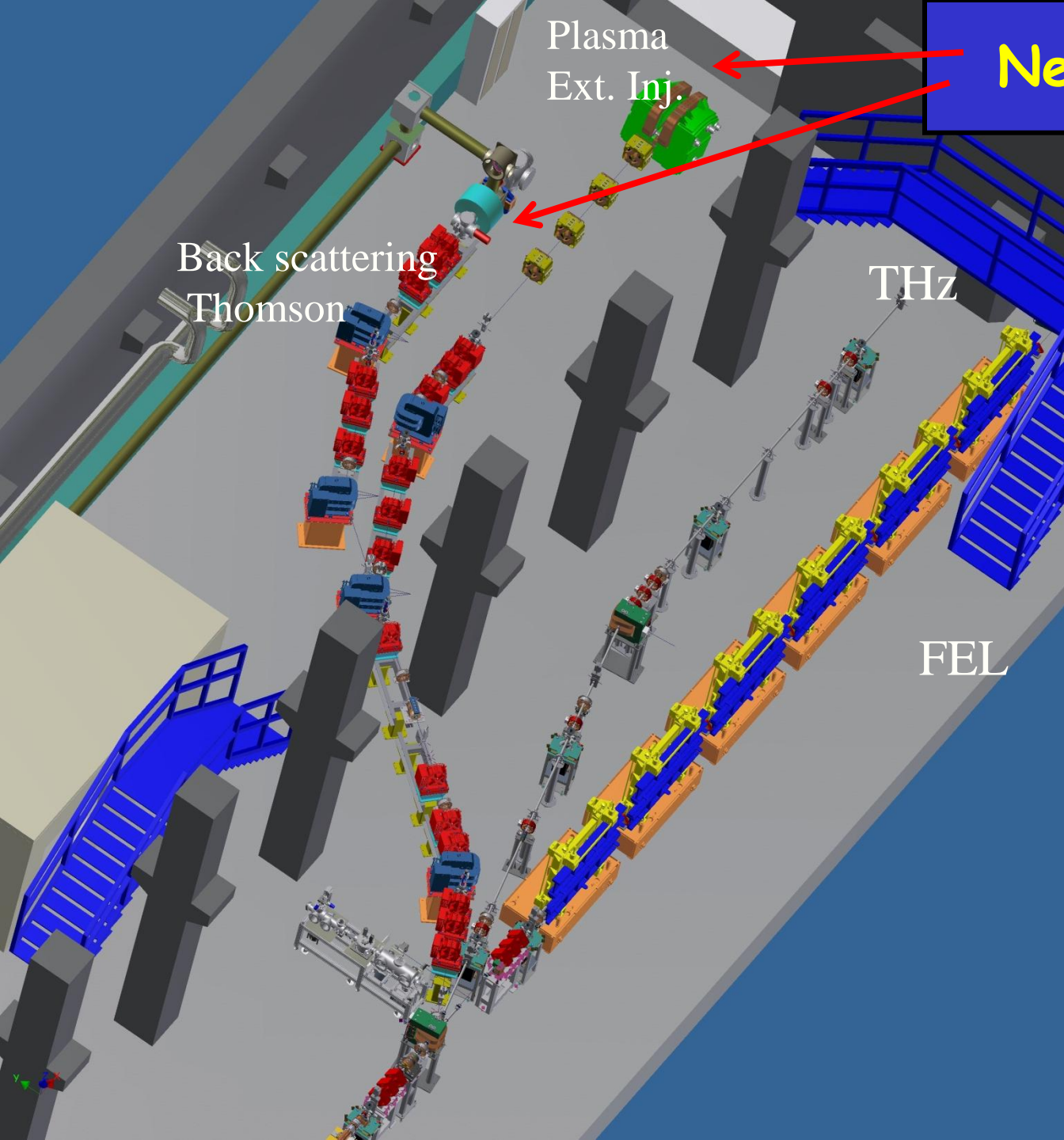

New installations

- Investigation of different configurations of plasma accelerator.
- Production of monochromatic ultra-fast X-rays by Thomson b-s driven by high-quality electron beam.

CNAO(Centro Nazionale Adroterapia Oncologica)

ACCELERATOR

Synchrotron

P : 60 – 250 MeV

C6+ :120 - 400 MeV

3 Treatment rooms

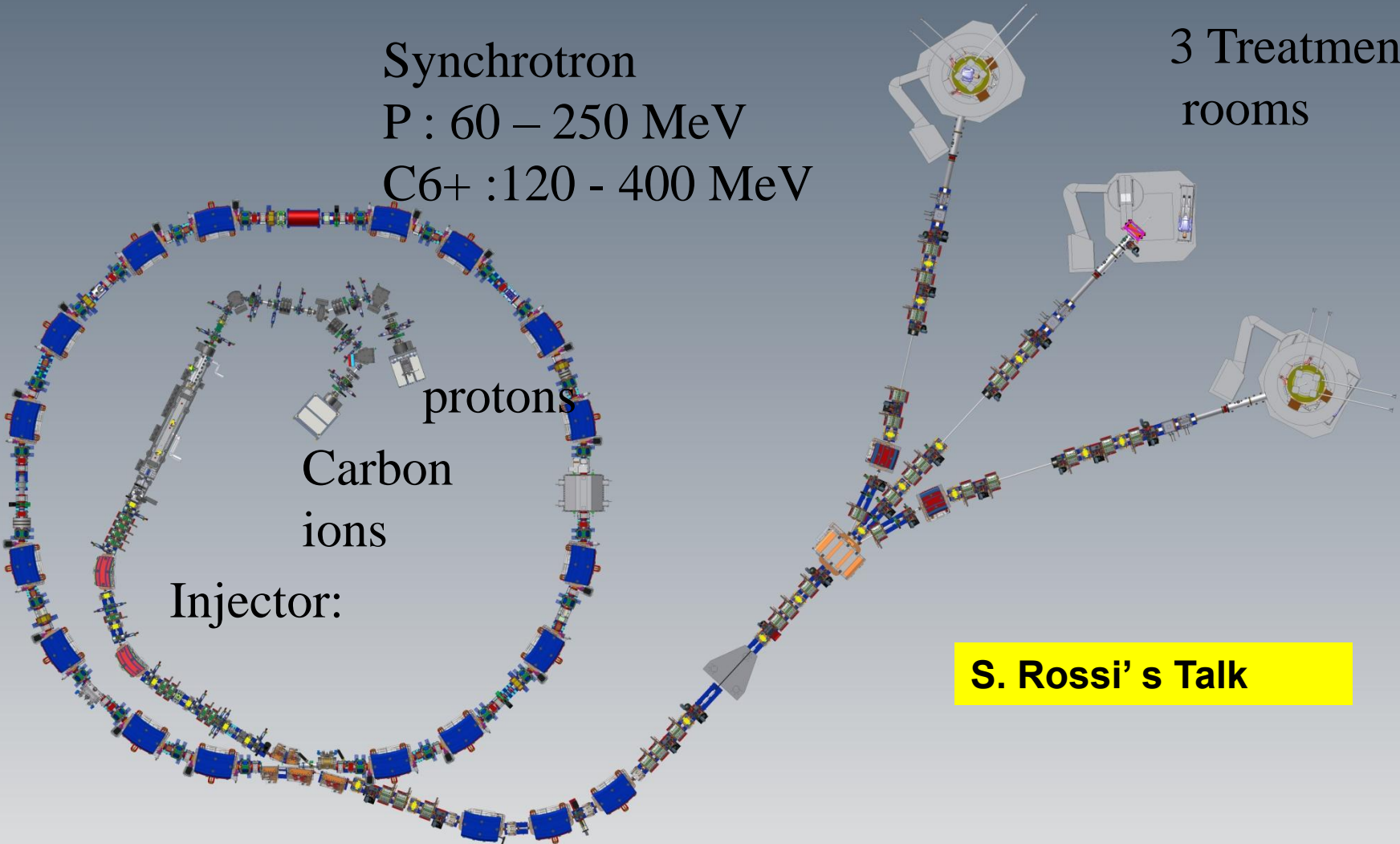

S. Rossi' s Talk

LNFAccelerator Division participated in the construction of the proton synchrotron.

Magnets delivered on Dec. 06 – Feb. 07
Installation schedule April – May 07

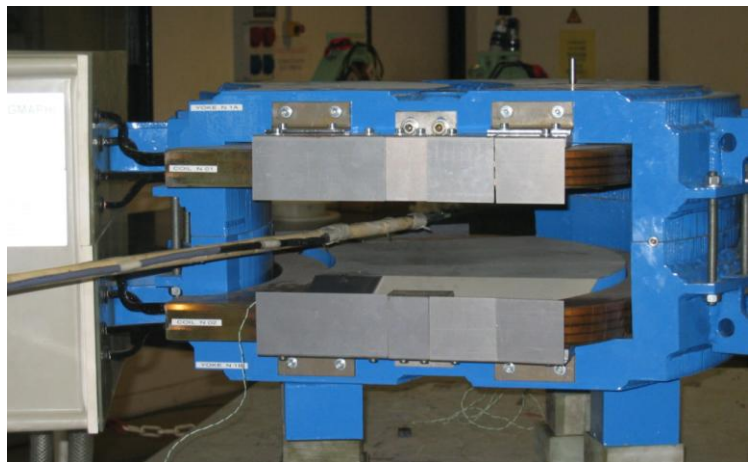
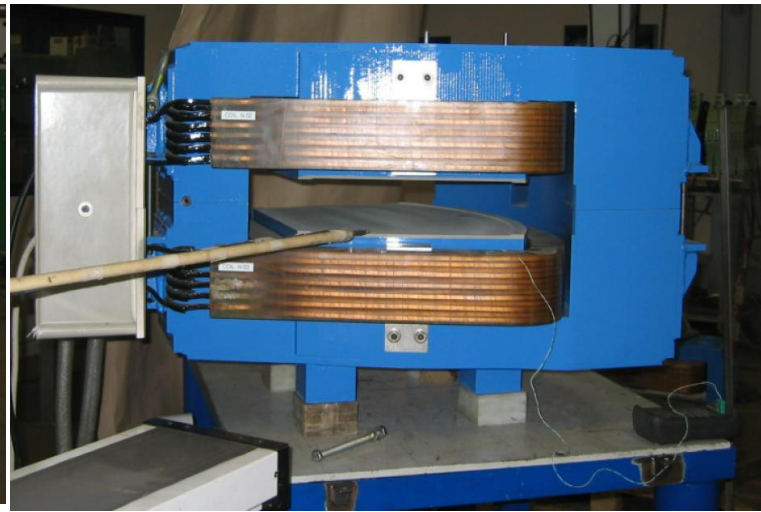
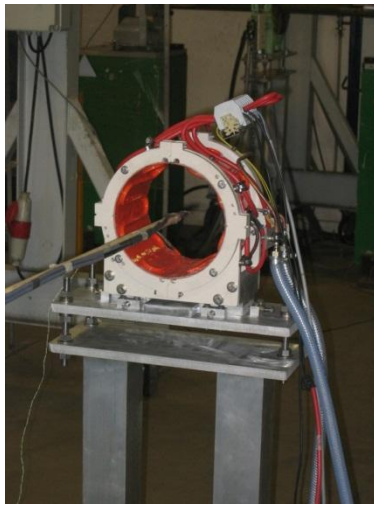
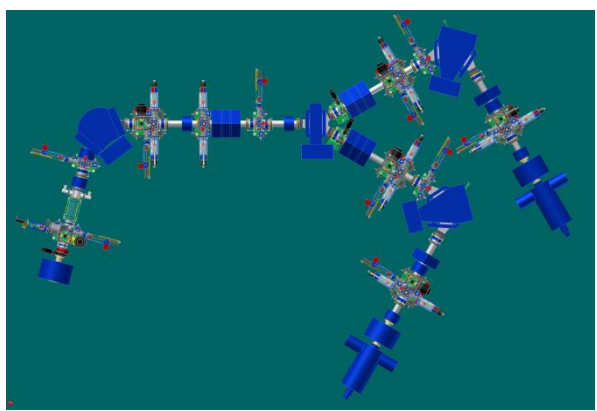

MAGNETS

Produced by Sigmaphi

In collaboration with:

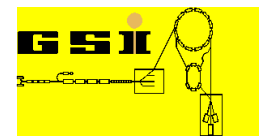
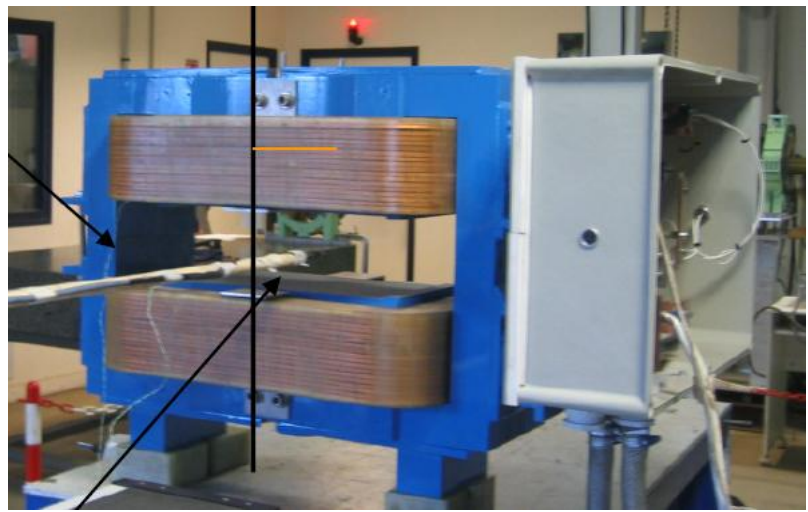
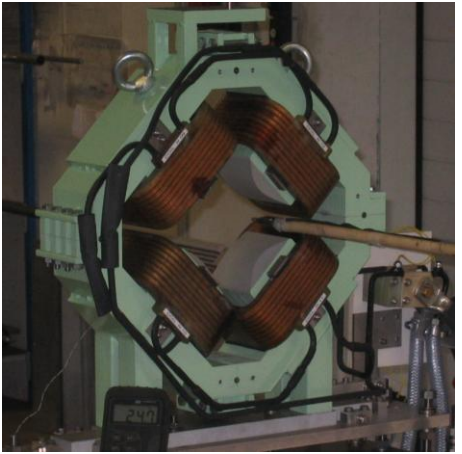

DAΦNE is completing its scientific program and, exploiting the know-how developed with this accelerator, we are pushing the project of a new factory, at higher energies and luminosities

The new accelerator SuperB

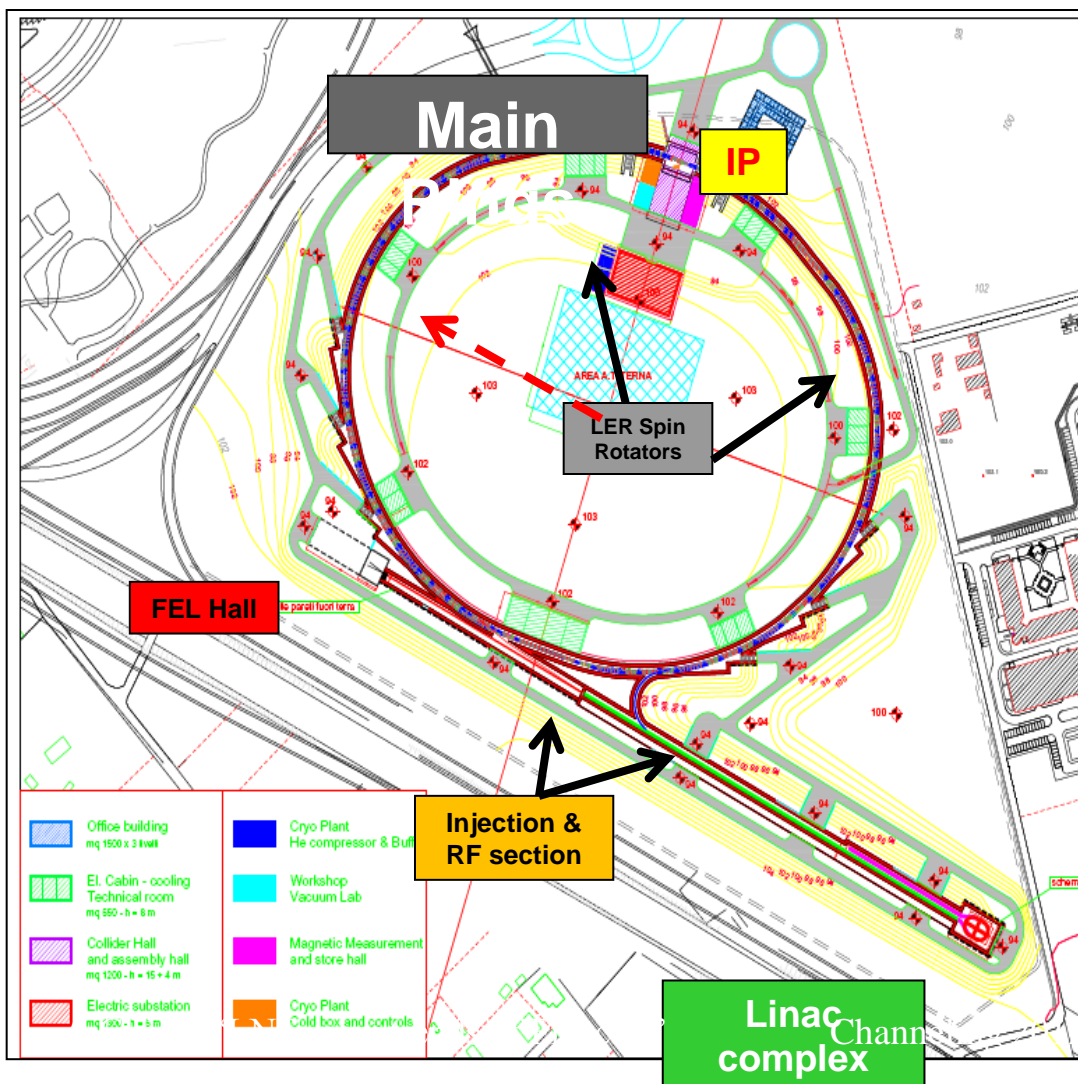

Parameter	SuperB	
	HER (e ⁺)	LER (e ⁻)
Luminosity (cm⁻²s⁻¹)	10³⁶	
C (m)	1200	
E (GeV)	6.7	4.18
Crossing angle (mrad)	60	
Piwinski angle	20.8	16.9
I (mA)	1900	2440
ε _{x/y} (nm/pm) (with IBS)	2/5	2.5/6.2
IP σ _{x/y} (mm/nm)	7.2/36	8.9/36
σ ₁ (mm)	5	5
N. bunches	978	
Part/bunch (x10 ¹⁰)	5.1	6.6
σ _E /E (x10 ⁻⁴)	6.4	7.3
bb tune shift (x/y)	0.0026/0.107	0.004/0.107
Beam losses (MeV)	2.1	0.86
Total beam lifetime (s)	254	269
Polarization (%)	0	70-80
RF (MHz)	476	

KEKB-DAFNE

Collaboration Meetings

- 1. ICFA Beam Dynamics Workshop on Collective Instabilities, Tsukuba, 1995**
- 2. Workshop on Beam Dynamics Issues for e+e- Factories, Frascati, 1997**
- 3. Workshop “e+e- Factories” at KEK, Tsukuba 1999**
- 4. DAFNE-KEKB Meeting at Frascati, February 2002**
- 5. DAFNE-KEKB Meeting on Control Systems at Frascati, January 2003**
- 6. Japan-Italy Collaboration Meeting “Crab Factories“, December 2008**

INFN-LNF KEK relationship

- Beam Dynamics studies in the existing INFN and KEK factories: crab waist adopted in SuperB and SuperKEK-B.
- Longitudinal and transverse feedback systems for DAFNE and KEKB
- High power test in KEK labs of C-Band RF structure realized in INFN LNF for SPARC