



*Italy - Japan  
2012*



**7<sup>th</sup> Italy - Japan Symposium  
on Nuclear Physics**



**November 20-23, 2012, Milano, ITALY**

***Particle vibration couplings  
in neutron-rich calcium region***

*Silvia Leoni*

*University of Milano & INFN*

# ***Collaboration***

## ***Milano University and INFN***

A. Bracco, G. Benzoni, N. Blasi, F. Camera, F. Crespi, S. Leoni, B. Million, O. Wieland, S. Bottoni, G. Bocchi et al.

***P.F. Bortignon, G.Colò***, E. Vigezzi et al.

## ***Legnaro INFN Laboratory***

L.Corradi, G. DeAngelis, E. Fioretto, D. Napoli, A. Stefanini, J.J. Valiente-Dobon, et al.

## ***Padova University and INFN***

D. Bazzacco, E. Farnea, S. Lenzi, S.Lunardi, A. Gottardo, G. Montagnoli, D.Montanari, F.Scarlassara, C.Ur, et al.

## ***Torino University and INFN***

G. Pollarolo

## ***IFIC, CSIC-University of Valencia, Spain***

A. Gadea, ...

## ***IFIN-HH Bucharest***

N. Marginean, C. Nita et al.

## ***Krakow, Poland***

A. Maj, P. Bednarczyk, B. Fornal, M. Kmiecik, M. Ciemala et al.,

## ***Ruder Boskovic Institute, Zagreb***

S. Szilner et al.

***AGATA- PRISMA collaborations***

# OUTLINE:

## □ INTRODUCTION

- 1.** Importance of Particle-Phonon correlations in nuclear structure studies
- 2.** Experimental and Theoretical Approach
- 3.** The case of  $^{49,47}\text{Ca}$ :  
Heavy-Ion Transfer reactions as a tool for complete in-beam  $\gamma$ -spectroscopy

## □ WORK in PROGRESS and PERSPECTIVES:

- 1.** Particle-Phonon Coupling around Ni Isotopes
- 2.** Future studies with RIB around  $^{132}\text{Sn}$

# HOT topic in Nuclear Structure

## Evolution of Shell Structure with $N/Z$

Study of Shell closures, Magic Numbers, Effective Nuclear Force, ...

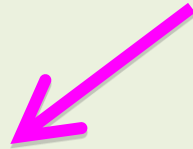

- **Doubly Magic Nuclei**
- **Near to Magic Nuclei**  
(1 and 2 nucleons away)

## Experimental Tools

- **Coulex**  
→ Collectivity  $B(E2)$ ,  $B(E3)$ , ...
- **Knock-out, transfer reactions, ...**  
→ **Spectroscopic Factors**  
Purity of nuclear states  
*Single particle* ( $SF \sim 1$ )  
*Correlations* ( $SF < 1$ )

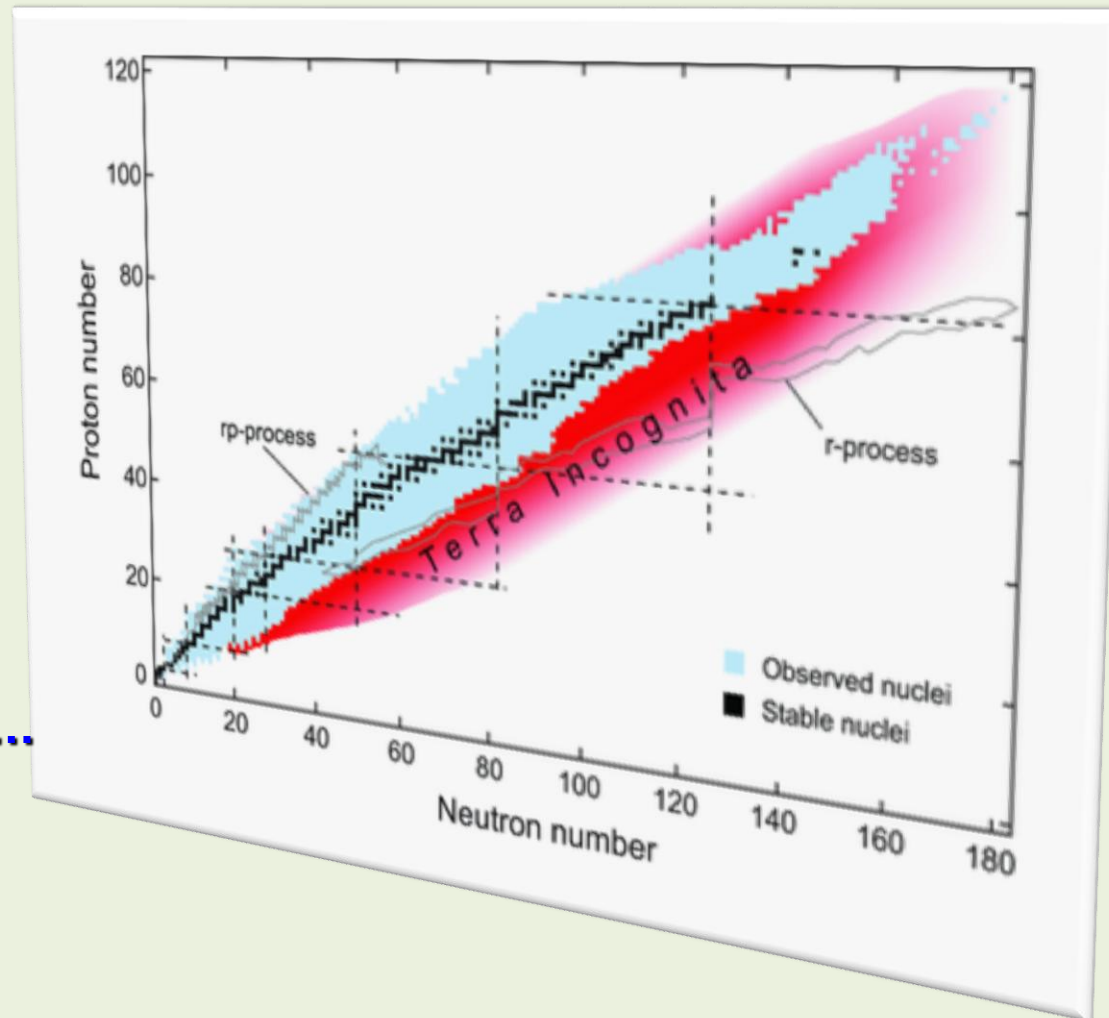

# Spectroscopic Factors

Nature and Occupancy of single-particle orbits  
 → Interplay Single-Particle and Collectivity

$$S_{l,j} = \frac{\left(\frac{d\sigma}{d\Omega}\right)_{EX}}{\left(\frac{d\sigma}{d\Omega}\right)_{DWBA}}$$

## Crucial test of Shell Model and Interactions

L. Lapikas, Nucl. Phys. A553, 297c (1993)

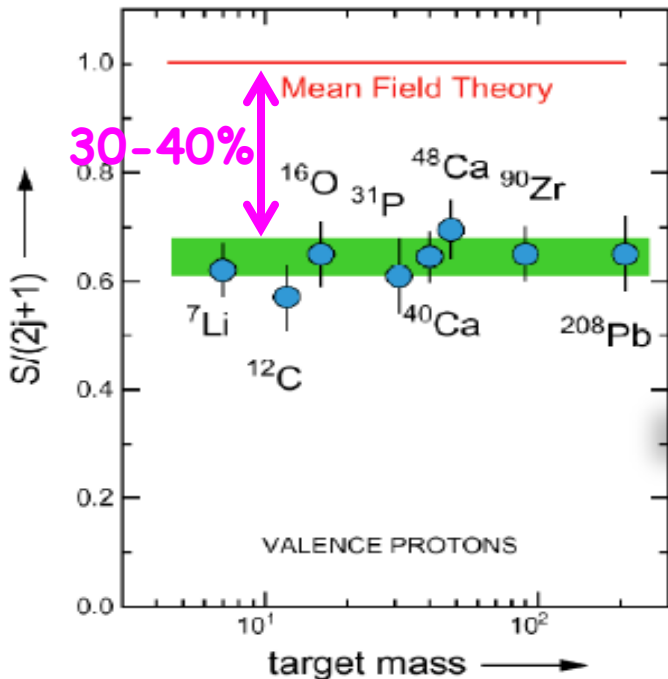

30-40 % reduction of SF compared to Independent Particle Model

$^{208}\text{Pb}(e, e'p)^{207}\text{Tl}$

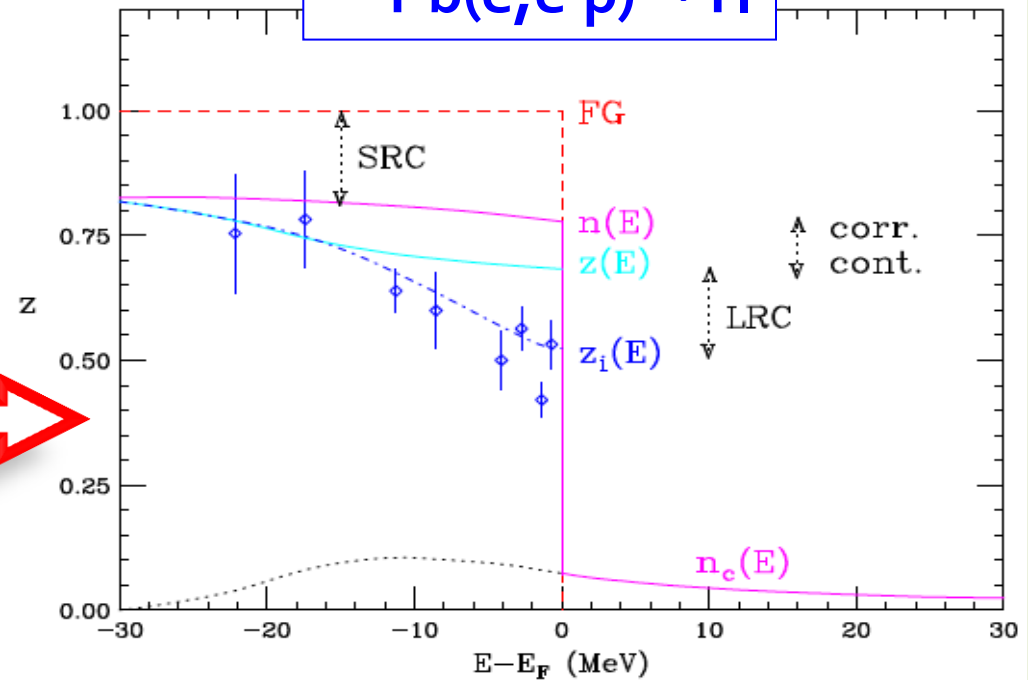

Quenching of SF due to correlations:  
**SHORT** Range: Deeply Bound States  
**LONG** Range (coupling to vibrations): Surface States

# Large Basis Shell Model (LB-SM)

## Correlations among valence nucleons

M.B. Tsang et al. PRL102(2009)062501

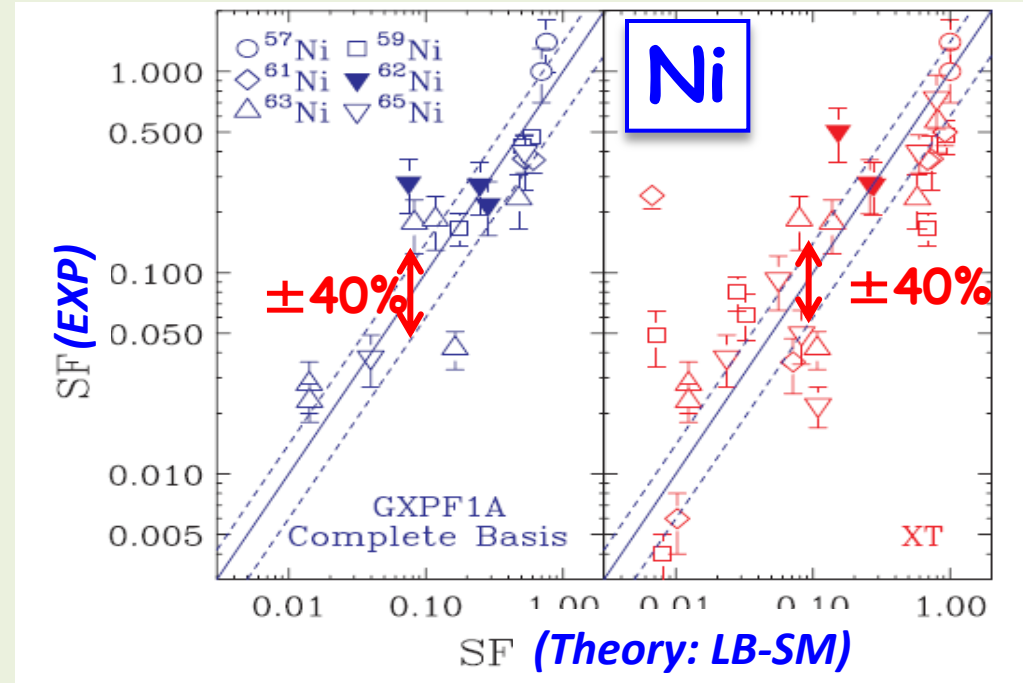
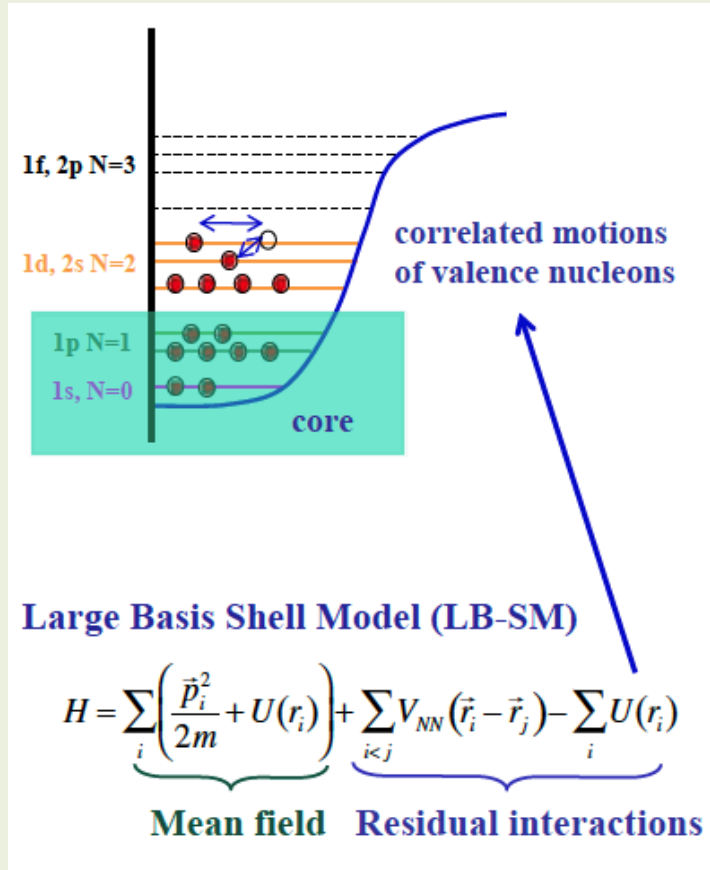

### Source of discrepancies

- Core excitations
- State fragmentation ...

**→ Coupling between Particle and Vibrations is not included ...  
(LONG RANGE CORRELATION)**

# Spectroscopic Factors

## Information from Exotic Nuclei

$$S_{l,j} = \frac{\left(\frac{d\sigma}{d\Omega}\right)_{EX}}{\left(\frac{d\sigma}{d\Omega}\right)_{DWBA}}$$

A. Gade et al. PRC77(2008)044306

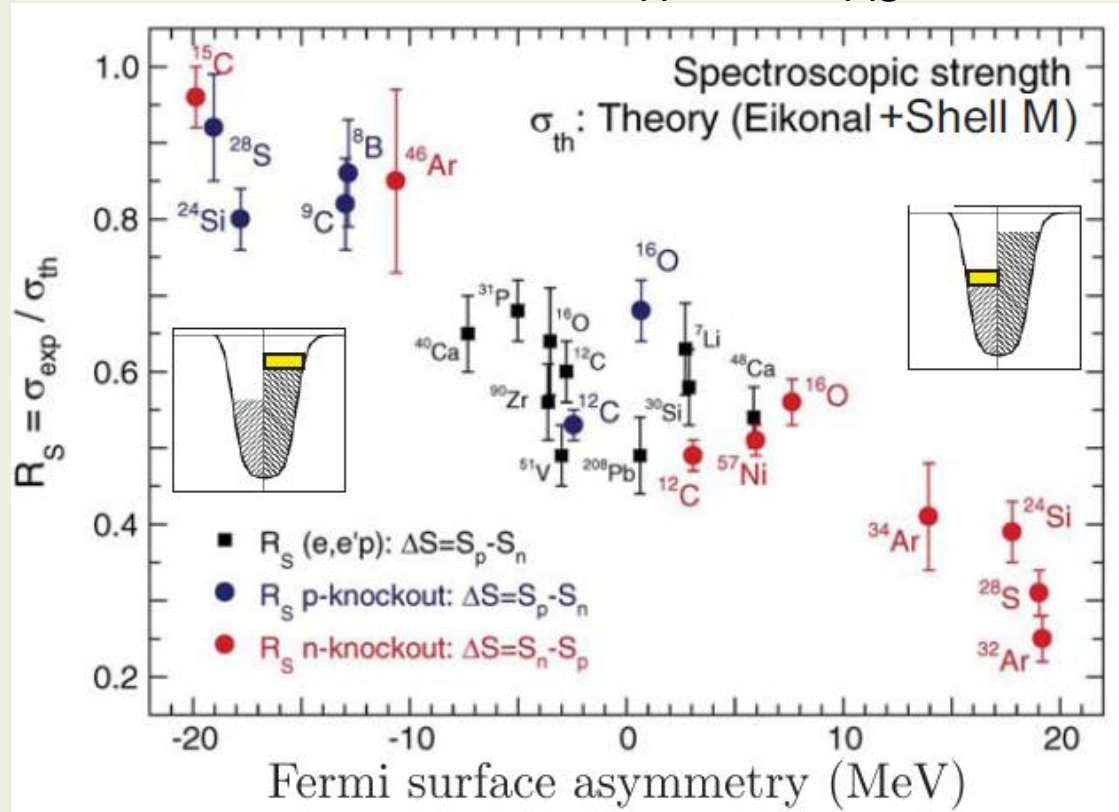

### Dependence on Fermi Surface

Enhanced *CORRELATIONS* in Strongly bound valence nucleons

*Need for a more profound investigation of correlations*  
 → *Long Range Correlations*

# Focus on Long Range Correlations

→ *only partially included in Shell Model*

## Coupling between Particle and Phonon

### Key Ingredient for:

- ❑ Quenching of Spectroscopic Factors
- ❑ Anharmonicity of vibrational spectra
- ❑ Damping of Giant Resonances, ...
- ❑ Effective Masses, ...

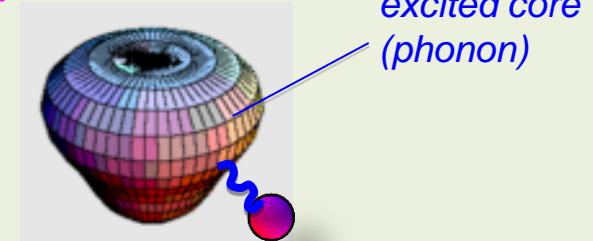

**Research Program in Milano**  
**FOCUS on Particle-Phonon Coupled States**  
*Systematic Study around magic nuclei: Ca, Ni, Sn, ...*

### **Experiments:**

Transfer with Heavy-Ions @ LNL  
(n, $\gamma$ ) and (n,Fission) @ ILL  
 $^7\text{Li}$  reactions @ Bucarest

→ *Preparatory work for  
SPES, SPIRAL<sub>2</sub>, HE-ISOLDE, ...*

### **Theory (Colò, Bortignon):**

#### **Coupling with 1 particle**

- *effective single particle levels*
- *coupling strength*

#### **Coupling with 2 particles**

- *core + 2 particles model*
- *physics of pairing*

**Dependence on Fermi Surface**

# Experimental STATUS

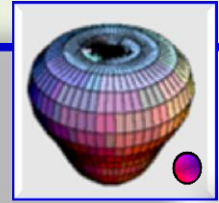

Up to now: **Scarce Information Mostly in Heavy-Masses**

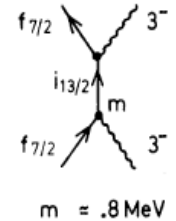
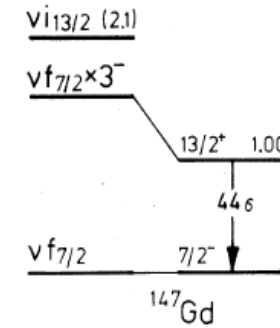
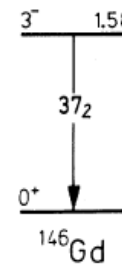
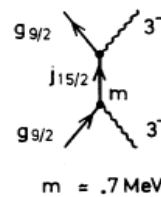
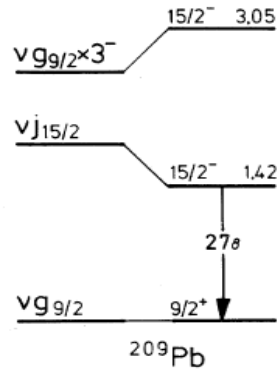
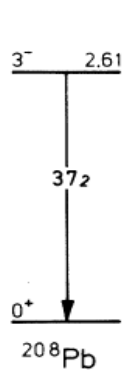

**A ~ 200**

- $^{209}\text{Bi}$ : Bohr & Mottelson, Vol. II.
- $^{209}\text{Pb}$ : P. Kleinheinz et al., PRL48(1982)1457
- $^{207}\text{Pb}$ : N. Pietralla et al., PLB681(2009)134

**A ~ 150**

- $^{147}\text{Gd}$ ,  $^{147}\text{Tb}$ : P. Kleinheinz et al., PRL48(1982)1457; P. Kleinheinz, Physica Scripta 24(1981)236.



Evidence for **Particle-phonon couplings** in **A~50 Nuclei**

$$^{49}\text{Ca}: 9/2^+ @ 4017 \text{ keV} = 3^- \otimes p_{3/2}$$

$$^{47}\text{Ca}: 11/2^+ @ 3999 \text{ keV} = 3^- \otimes f_{7/2}^{-1}$$

indication also in  $^{41,43}\text{Ar}$ : S. Szilner et al., PRC84(2011)014325

$^{65}\text{Co}$ : F. Recchia et al., PRC85(2012)064305 *lifetime analysis ??*

**→ Robustness of Collectivity in rather Light systems**

# Experimental Signature

- Multiplet of States:  $||-j| \leq l \leq |l+j|$
- $B(E\lambda)$  of phonon

46Sc	47Sc	48Sc	49Sc	50Sc	51Sc
45Ca	46Ca	47Ca	48Ca	49Ca	50Ca
44K	45K	46K	47K	48K	49K
43Ar	44Ar	45Ar	46Ar	47Ar	48Ar

**$48\text{Ca}$**   
( $Z=20, N=28$ )

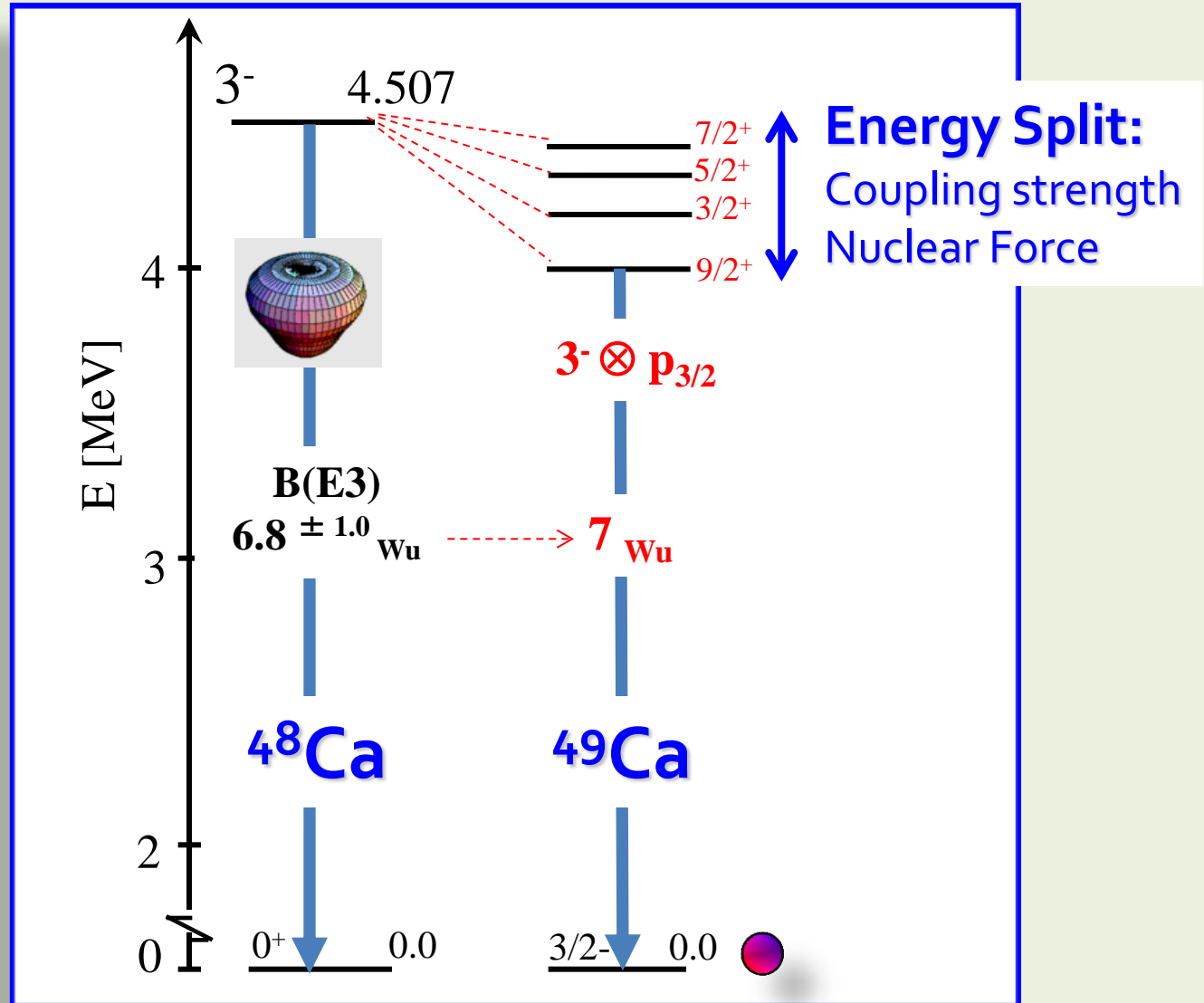

# Theoretical Description

**PHENOMENOLOGICAL**  
Particle-phonon  
WEAK coupling calculations  
(Bohr & Mottelson)

**$^{49}\text{Ca}$**   $3^- \otimes p_{3/2}$   
 $[\lambda \otimes j_1]_1$

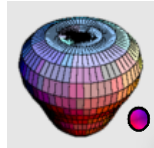

**Multiplet of States**  $9/2^+, 7/2^+, 5/2^+, 3/2^+$

**Energy Shift**  $\delta E(I)_{a,b,c,d} = \pm \sum_{i_1} \frac{\hbar^2(j_2, j_1, \lambda)}{\varepsilon(j_1) - \varepsilon(j_2) \pm \hbar\omega_\lambda} \times C_{\text{recoupling}}$

Lowest order  
Perturbative  
Contributions

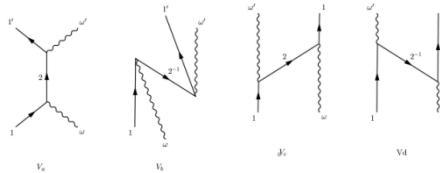

- $\hbar\omega_\lambda, B(E\lambda)$   
→ Exp. Values
- s.p. Energies  
 $\varepsilon(j_1), \varepsilon(j_2)$   
→ HF - SkX
- matrix element  
 $h(j_2, j_1, \lambda)$   
→ Bohr & Mott.

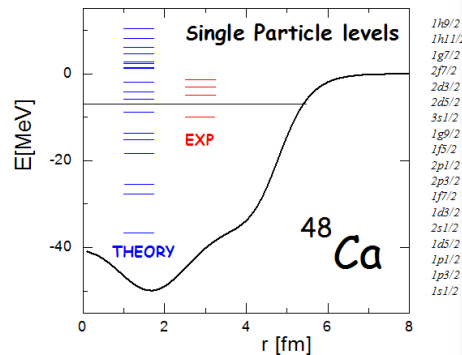

**MICROSCOPIC**  
Calculations based on  
SELF-CONSISTENT Scheme  
(Colò, Bortignon, Sagawa, ...)

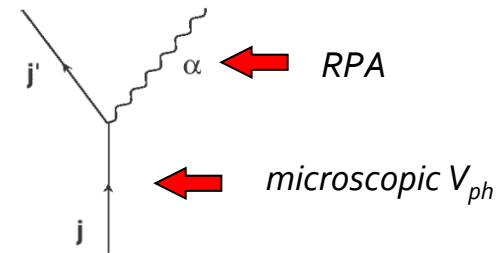

- Hartee-Fock with  $V_{\text{eff}}$   
→ short-range correlations included
- Particle-Vibration coupling on top  
→ same Hamiltonian or EDF

- NO approximation in the vertex

EXACT treatment of COUPLING

use of WHOLE phonon wave function

**Need for More Experimental Input**

# Best Reaction Mechanism ... ?

*It has to enhance collective (core)-excitations*

- ***Fusion Reactions***

- ***Incomplete Fusion Reactions***

*... need for RIB to reach n-rich systems*

- ***Heavy-Ion Transfer Reactions***

*... population of moderately n-rich nuclei  
even with stable beams*

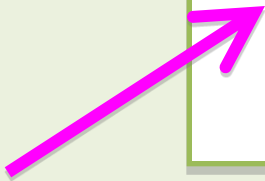

# Multi-Nucleon Transfer Reactions as a TOOL to study n-rich nuclei

Stable nuclei

126

**CLARA/AGATA-PRISMA campaigns @ LNL since 2004- ...**

*Structure of moderately n-rich nuclei*

*using most n-rich beams by PIAVE-Tandem-ALPI (5-10 MeV/A)*

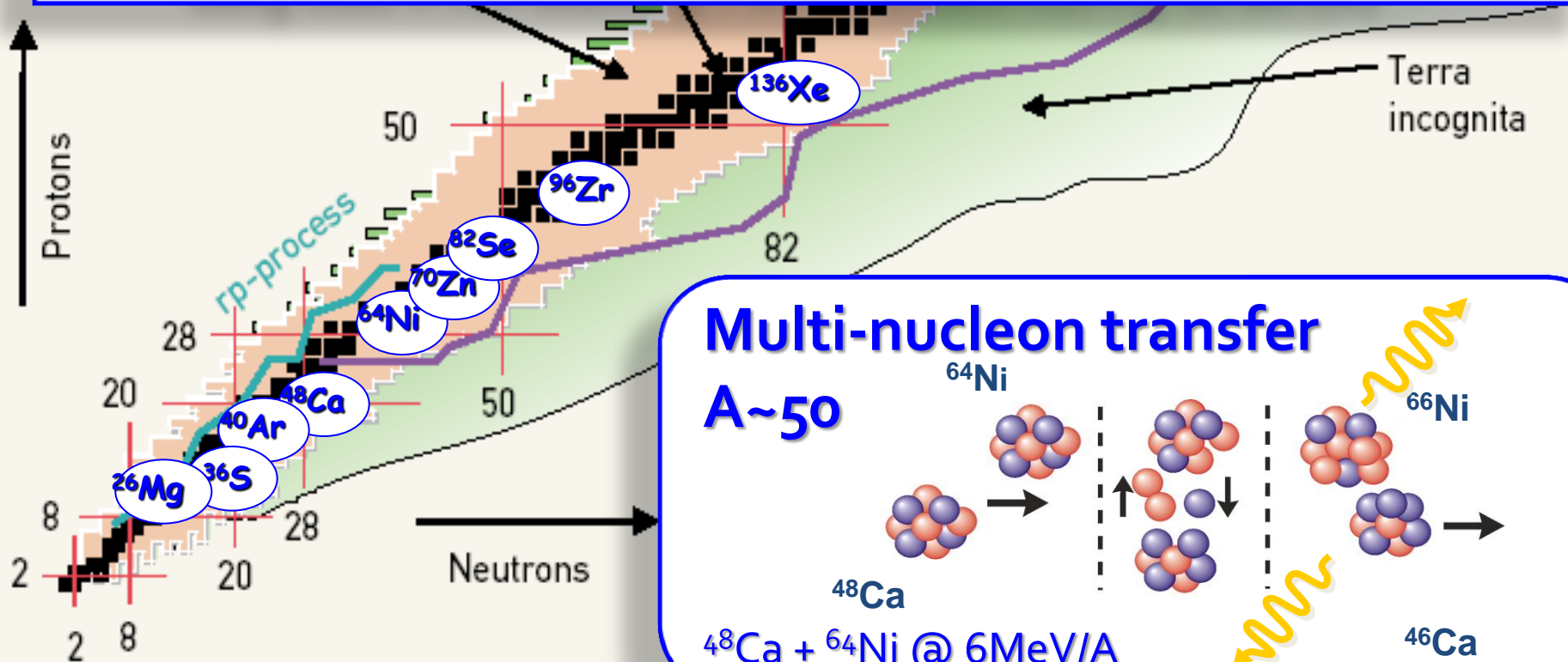

**Multi-nucleon transfer**  
**A~50**

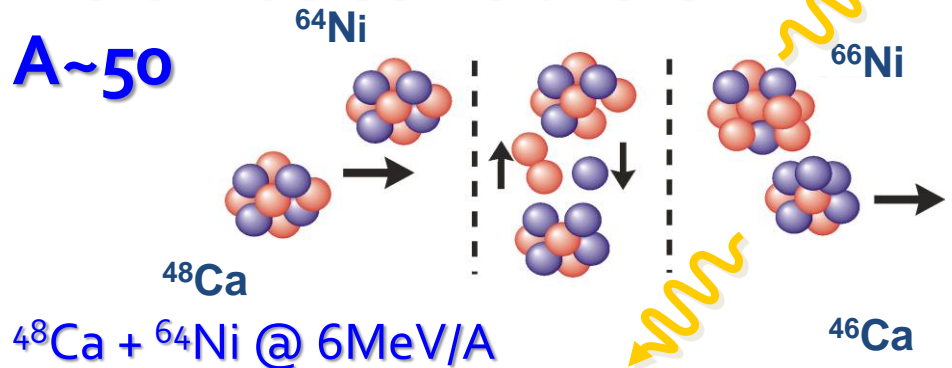

# CLARA (ex-EUROBALL)/AGATA – PRISMA setup

Legnaro National Laboratory INFN (Italy)

**AGATA Demonstrator @ LNL**  
Physics Campaign 2010-2011



**CLARA**

25 EUROBALL HpGe Clover

$\epsilon \sim 3\%$  @  $E_\gamma = 1.3$  MeV

$2\pi$  solid angle

3 rings at  $100^\circ$ ,  $130^\circ$ ,  
 $150^\circ$

**PRISMA**

$\Delta\Omega = 80$  msr

$\Delta Z/Z \approx 1/60$

$\Delta A/A \approx 1/190$

Energy acceptance  $\pm 20\%$

$B\rho = 1.2$  Tm

**High-Efficiency  $\gamma$ -particle coincidence Measurements**

# CLARA

**25 EUROBALL HpGe Clover**

$\epsilon \sim 3\%$  @  $E_\gamma = 1.3$  MeV

P/T  $\sim 45\%$

$2\pi$

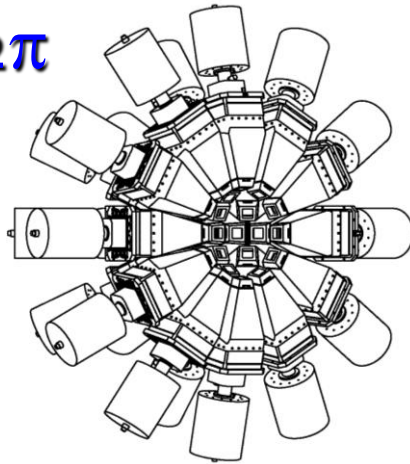

Composite Ge

50mmx70mm

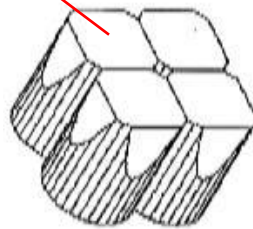

Compton  
Polarimeters

**3 RINGS**

$\theta = 100^\circ, 130^\circ, 150^\circ$

Angular  
Distributions  
 $\gamma$  rays

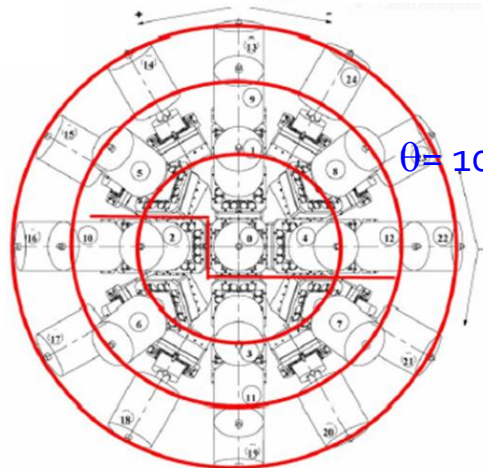

*CLARA always opposite to PRISMA*

# PRISMA

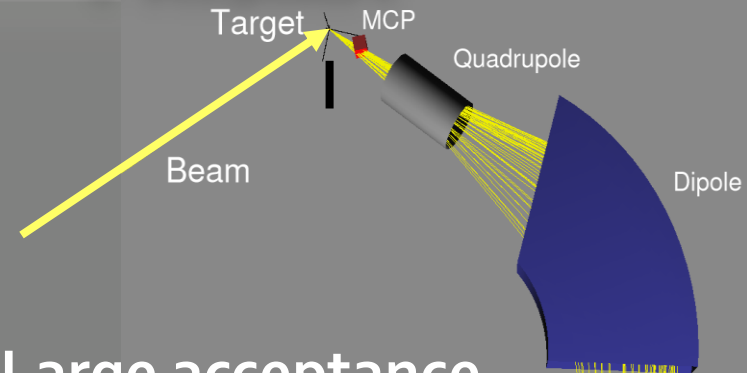

Large acceptance

Magnetic  
Spectrometer

$\Delta\Omega = 80$  msr

$\Delta Z/Z \approx 1/60$

$\Delta A/A \approx 1/190$

Energy acceptance  $\pm 20\%$

$B\rho = 1.2$  Tm

PPAC

$\Delta E/E$

Trajectory Reconstruction - Ion identif.

**Legnaro National Laboratory INFN (Italy)**

$^{48}\text{Ca} + ^{64}\text{Ni}$  @ 6 MeV/A ( $v/c \sim 10\%$ )

# CLARA + PRISMA

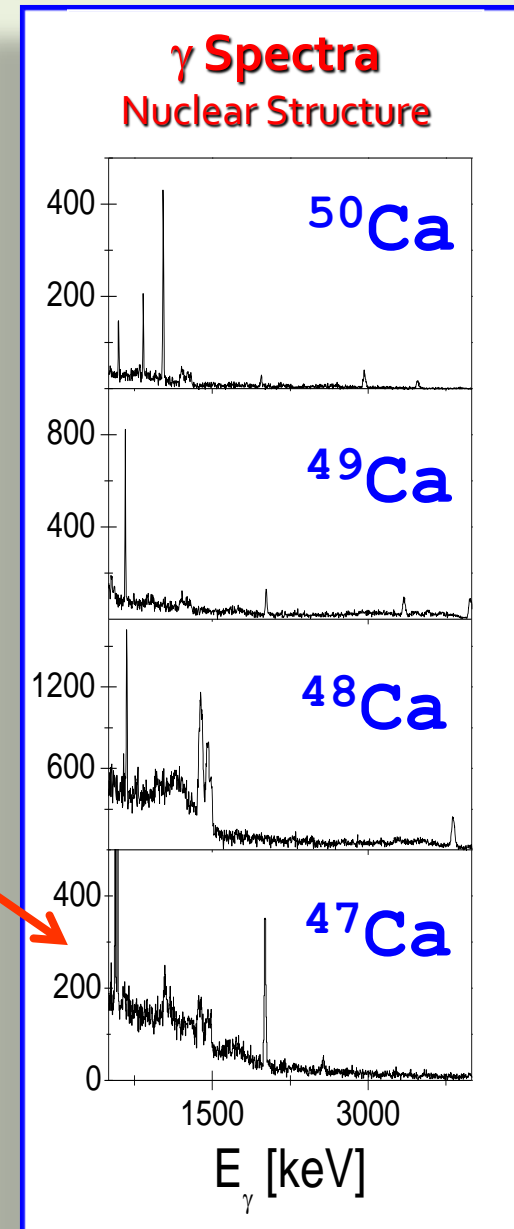
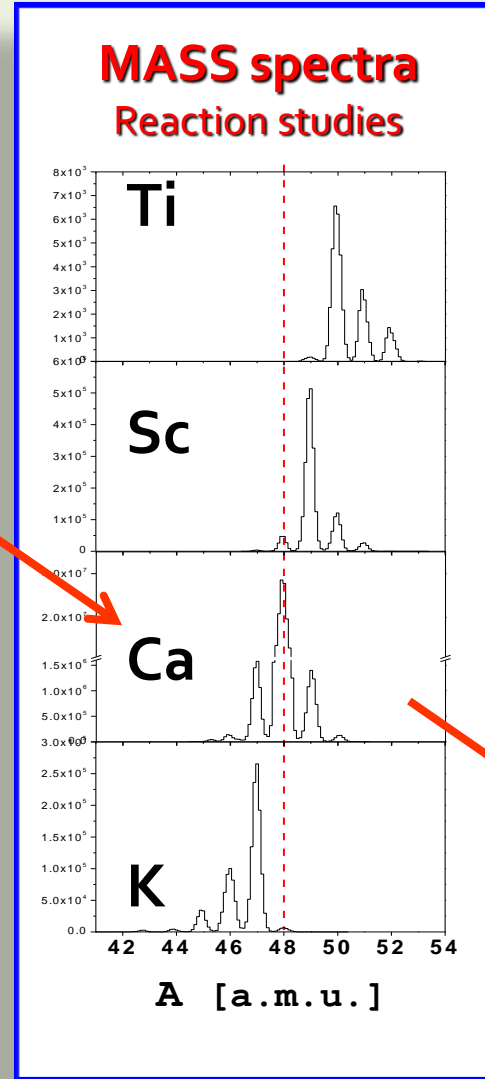
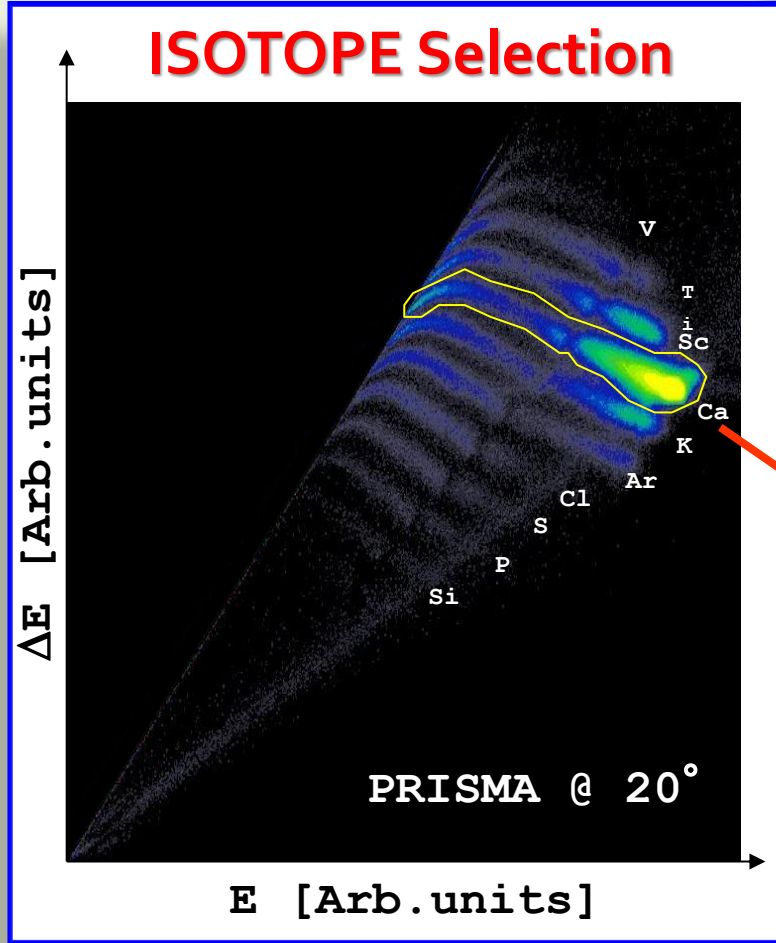

# $\gamma$ -particle Coincidence Measurements

$^{48}\text{Ca} + ^{64}\text{Ni}$  @ 6MeV/A

## 1 – Reaction Studies

Angular Distributions of ions (Inclusive and  $\gamma$ -gated)

D. Montanari, S. Leoni et al., Phys. Rev. C84(2011)054613

D. Montanari, S. Leoni et al., EPJA47(2011)4

*Need for a careful study of spectrometer response*

## 2 – Gamma Spectroscopy

Angular Distributions

Polarizations

Lifetime Analysis

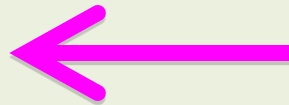

***→ Spin, Parity and Nature of State***

D. Montanari, S. Leoni et al., Phys. Lett. B697(2011)288

D. Montanari, S. Leoni et al., Phys. Rev. C85(2012)044301

# $\gamma$ -Ray Angular Distributions in CLARA Array

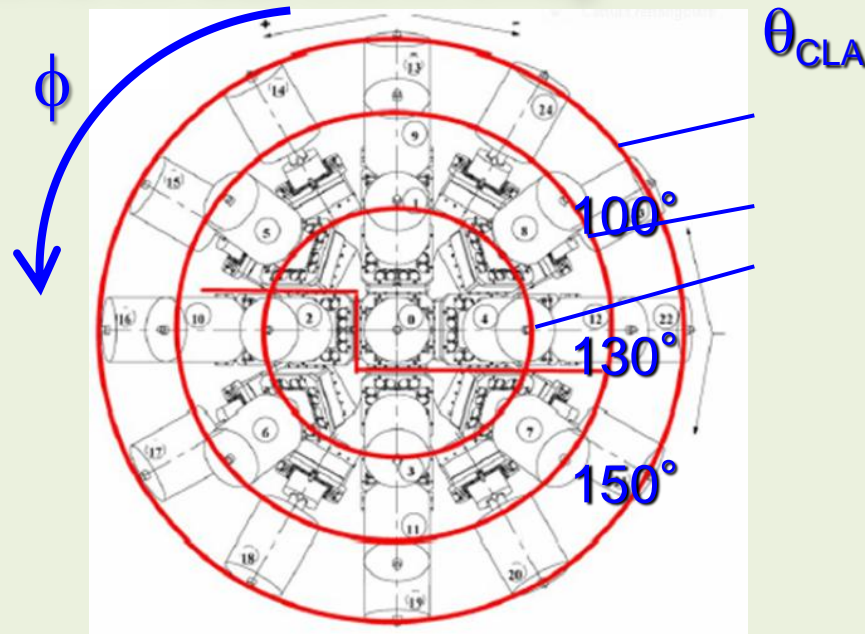
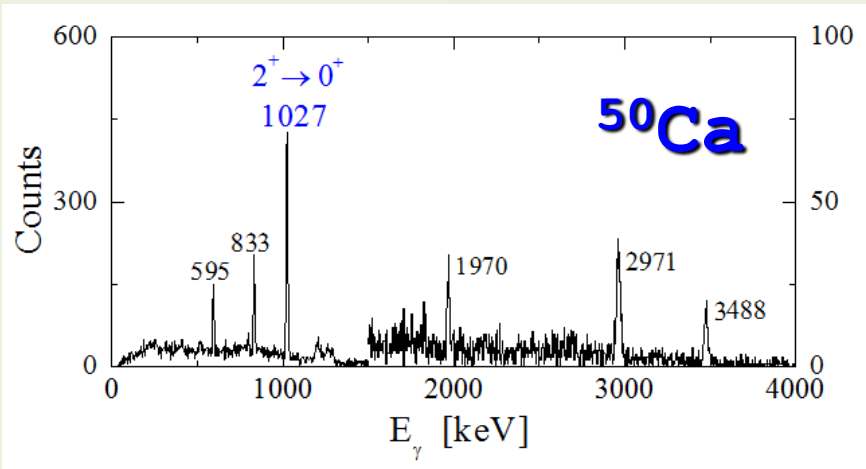

$$W(\theta) = 1 + \alpha_2 A_2 P_2(\cos \theta)$$

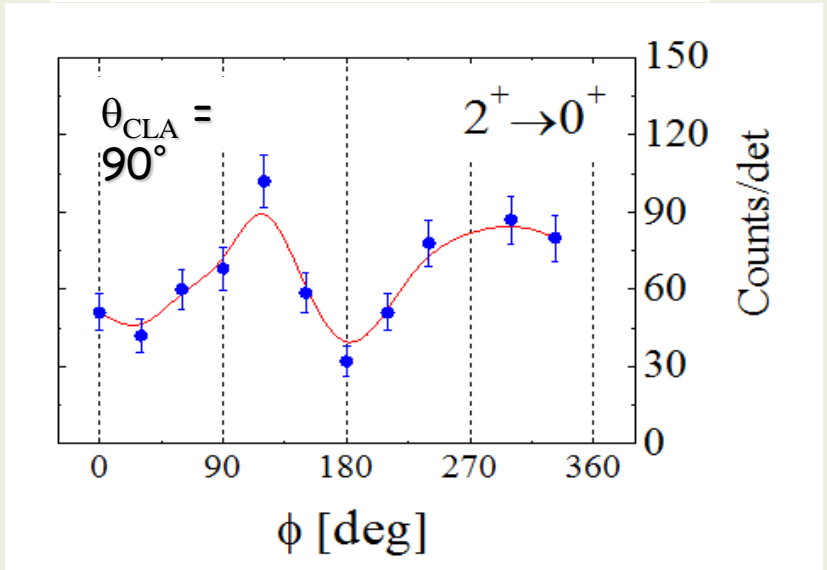
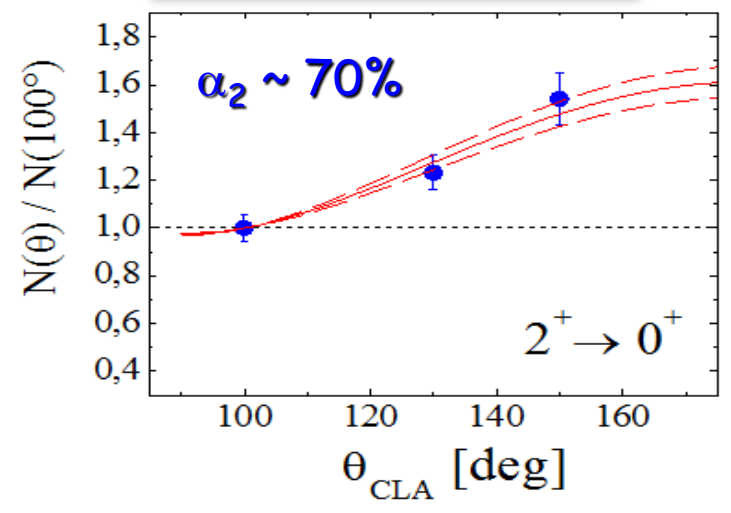

**Oblate SPIN Alignment perpendicular to reaction plane**

## Similar Anisotropy for known $\Delta I = 2$ transitions

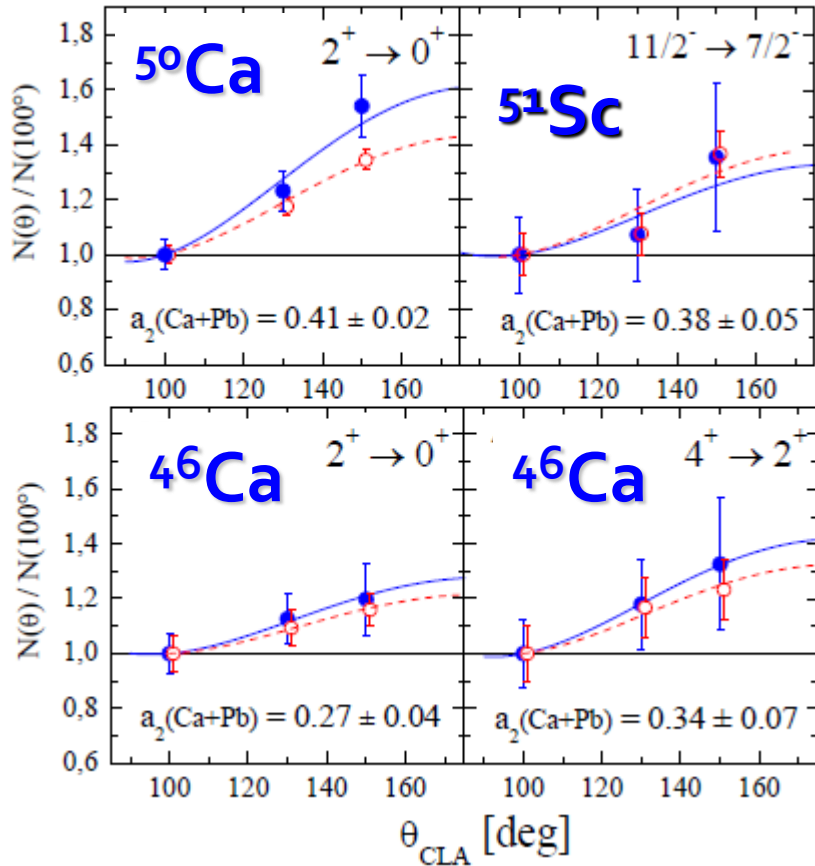

$^{48}\text{Ca} + ^{64}\text{Ni}$  @ 282 MeV

$^{48}\text{Ca} + ^{208}\text{Pb}$  @ 310 MeV

## Asymmetry of Compton Scattering in CLOVERs@90°

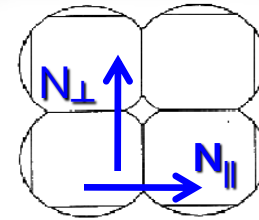

$$A_{\text{sym}} = \frac{N_{\perp} - N_{\parallel}}{N_{\perp} + N_{\parallel}} > 0 \quad \mathbf{E}$$

$$A_{\text{sym}} < 0 \quad \mathbf{M}$$

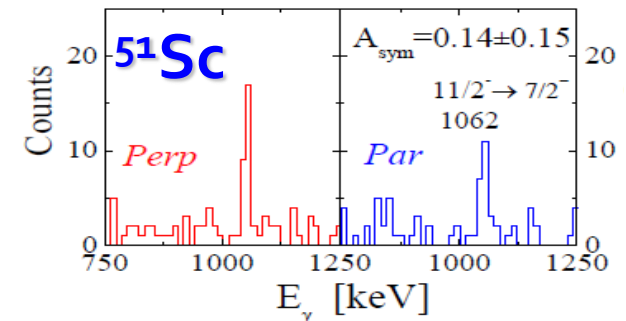
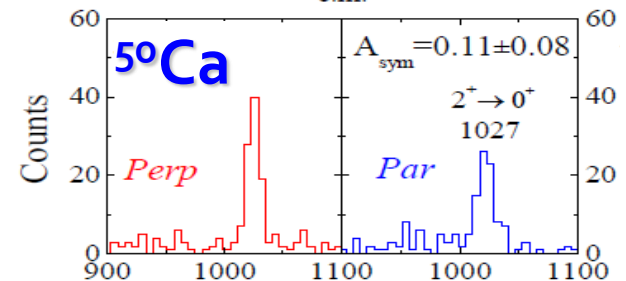
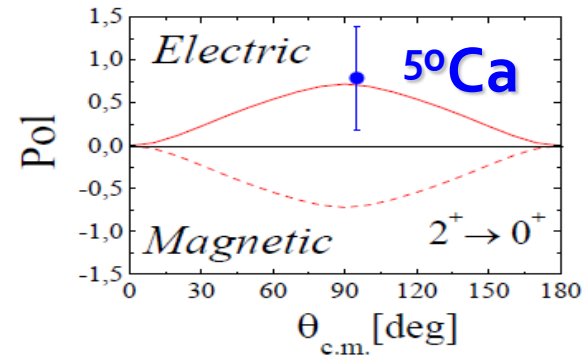

# Spectroscopy of $^{49}\text{Ca}$ : Spin and Parity Assignment

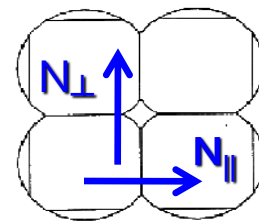
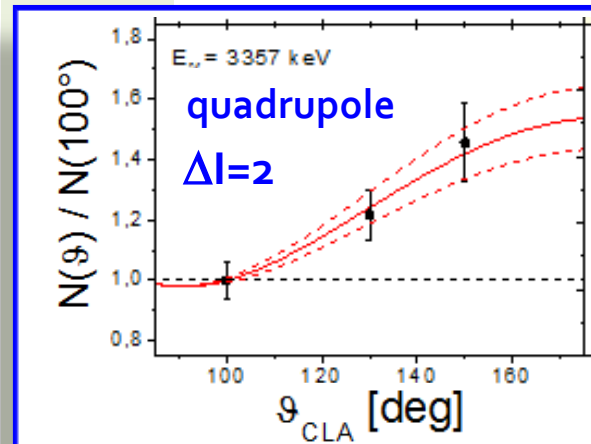
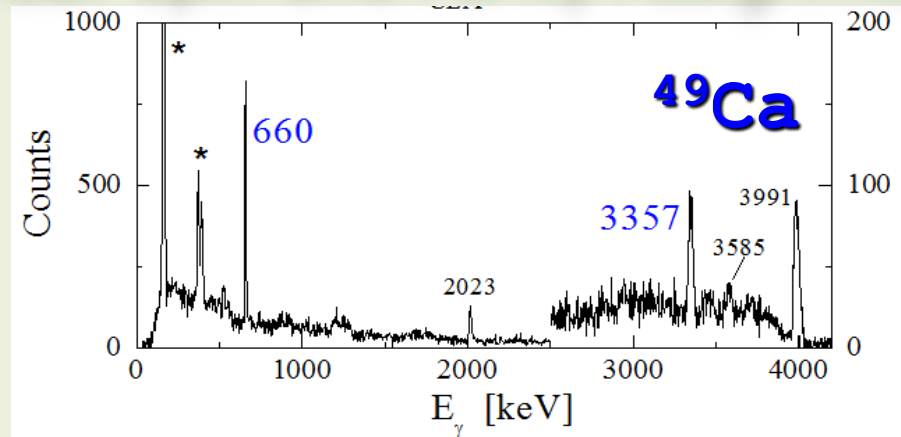
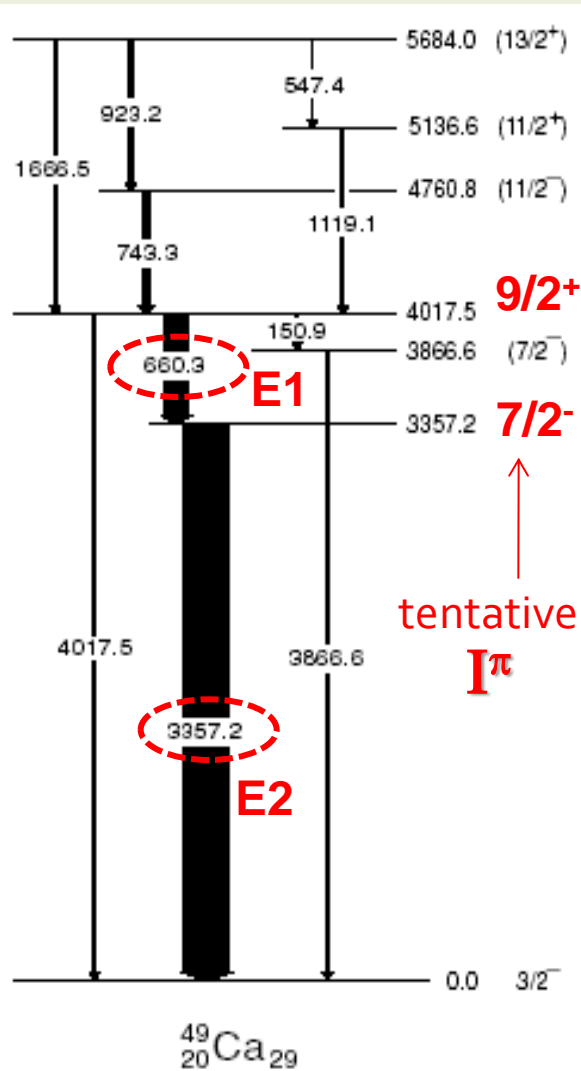

$$A = \frac{N_\perp - N_\parallel}{N_\perp + N_\parallel} = 0.08^{\pm 0.05} > 0$$

**Electric**

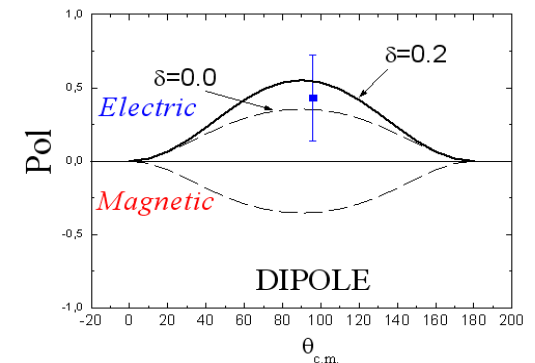
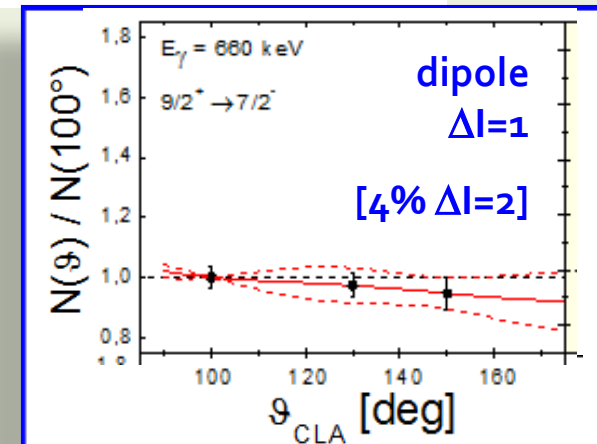

# Interpretation of $7/2^-$ and $9/2^+$

Core( $^{48}\text{Ca}$ ) - particle ( $p_{3/2}$ ) Couplings??

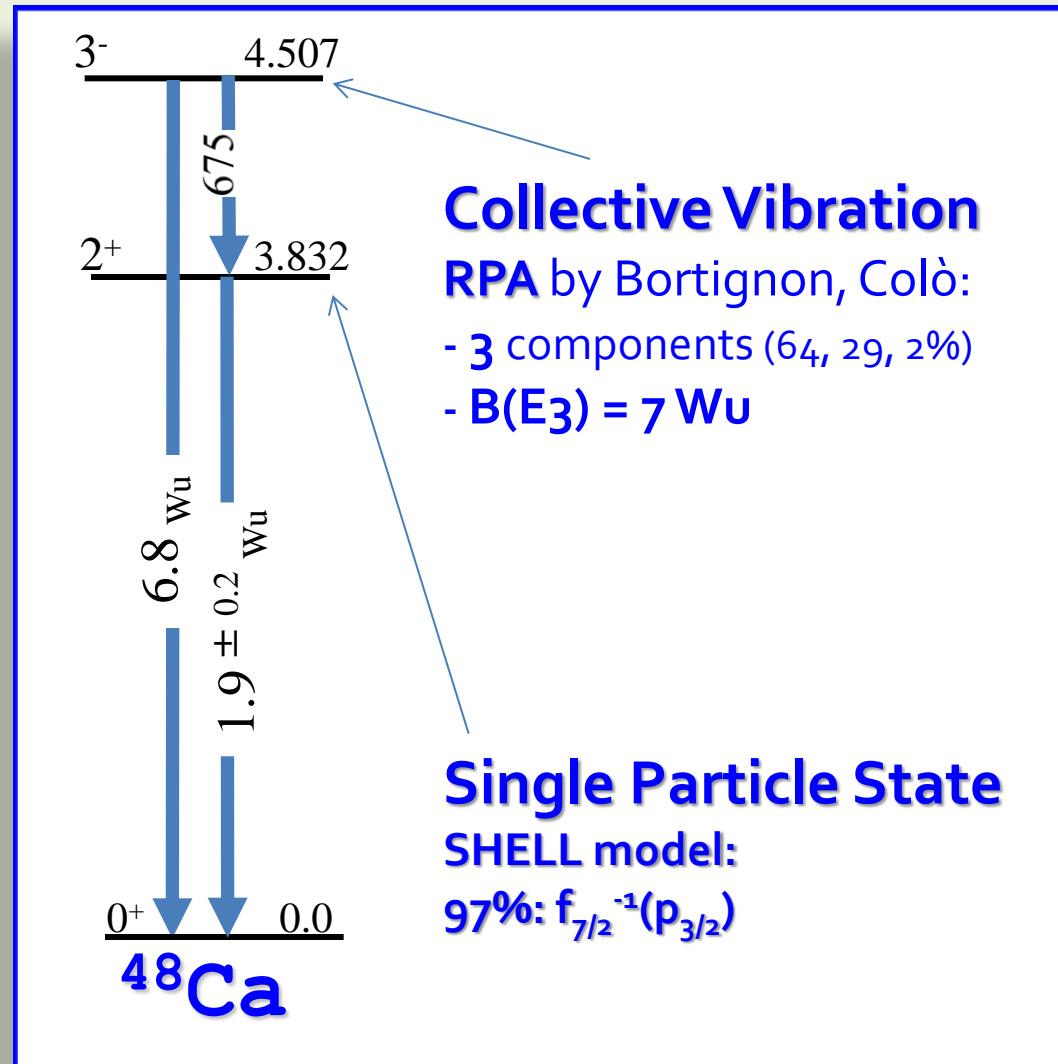
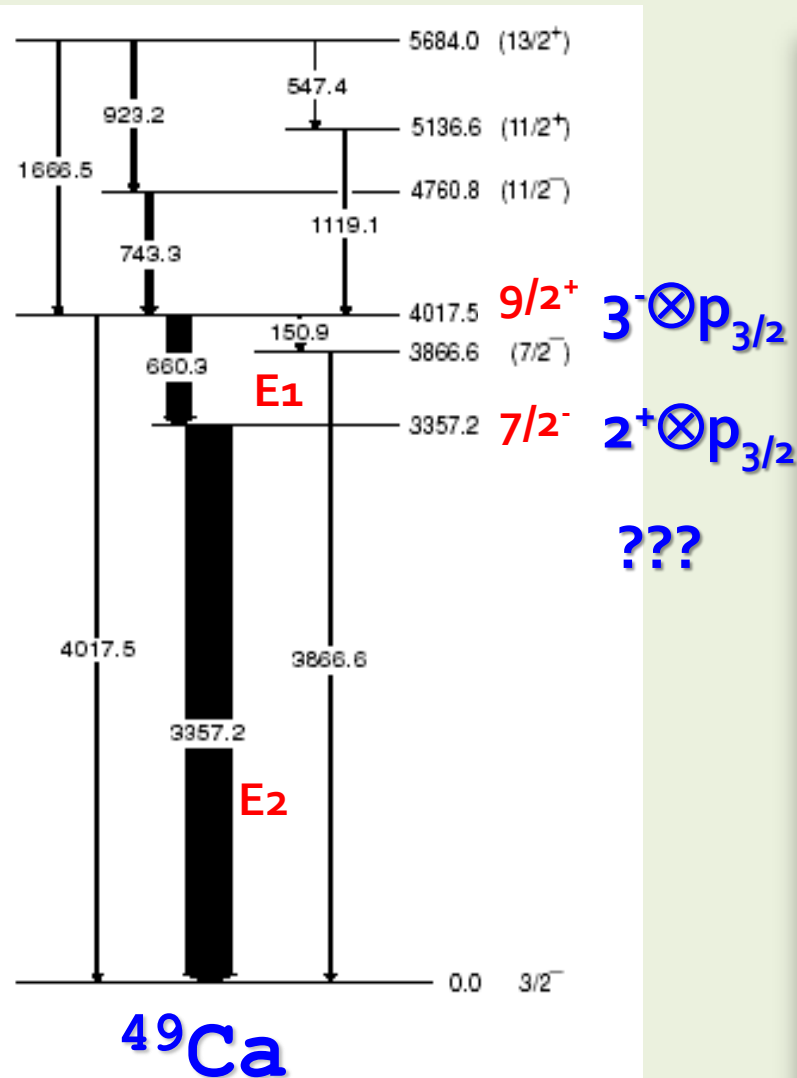

# $^{48}\text{Ca}$ : 3- RPA calculations

(G. Colò, P.F. Bortignon)

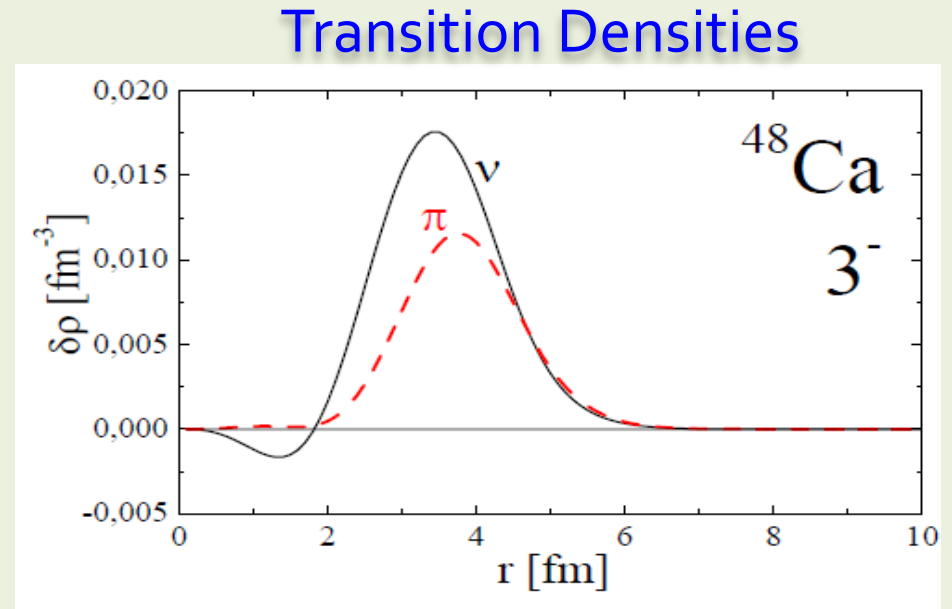
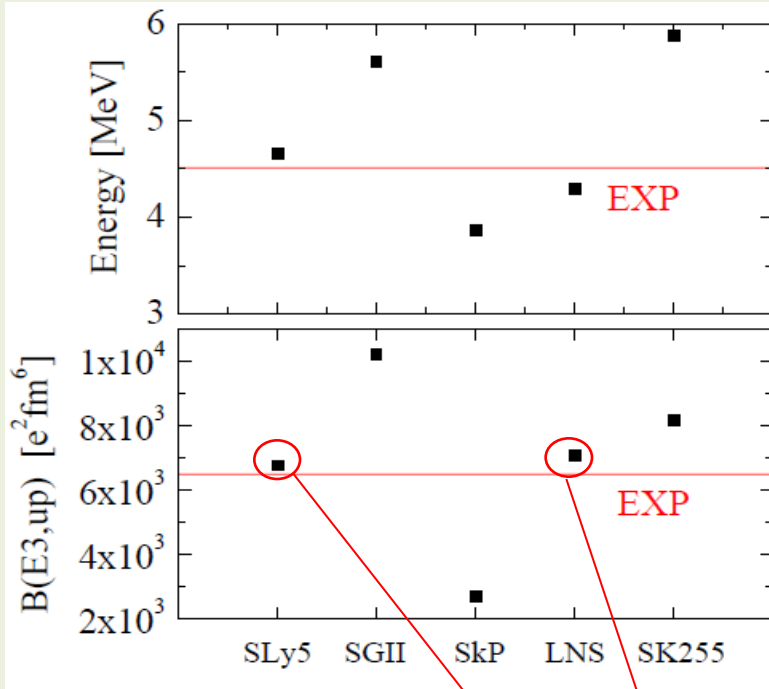

SLy5 - LNS				
$\pi$	$1d_{3/2} \rightarrow 1f_{7/2}$	0.82	0.64	
	$2s_{1/2} \rightarrow 1f_{7/2}$	0.13	0.29	
$\nu$	$1f_{7/2} \rightarrow 1g_{9/2}$	0.01	0.02	

“SIMPLE Structures”  
↓  
Macroscopic Core  
Vibration

# Lifetimes of $^{49}\text{Ca}$ with Differential PLUNGER

## Recoil Distance Doppler Shift Method @ PRISMA-CLARA

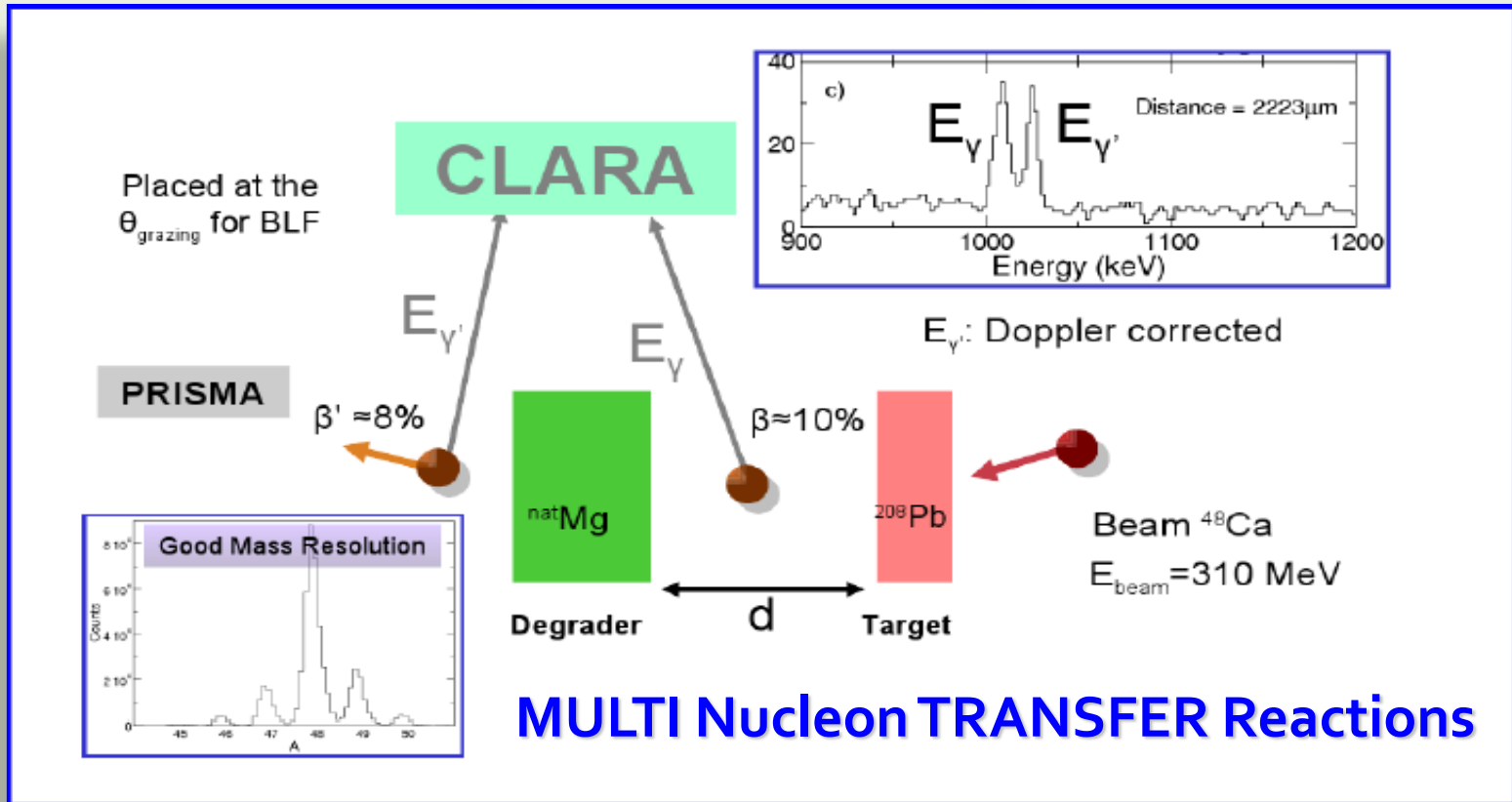

**$D = 30 \mu\text{m} - 2200 \mu\text{m}$**   
 **$\tau \sim 0.5 - 75 \text{ ps}$**

Lifetimes in  $^{50}\text{Ca}$ ,  $^{51}\text{Sc}$ ,  $^{44,46}\text{Ar}$   
Valiente-Dobon et al., PRL102(2009)242502  
D. Mengoni et al., PRC82(2010)024308



A. Dewald et al., Köln

# Lifetimes of $^{49}\text{Ca}$

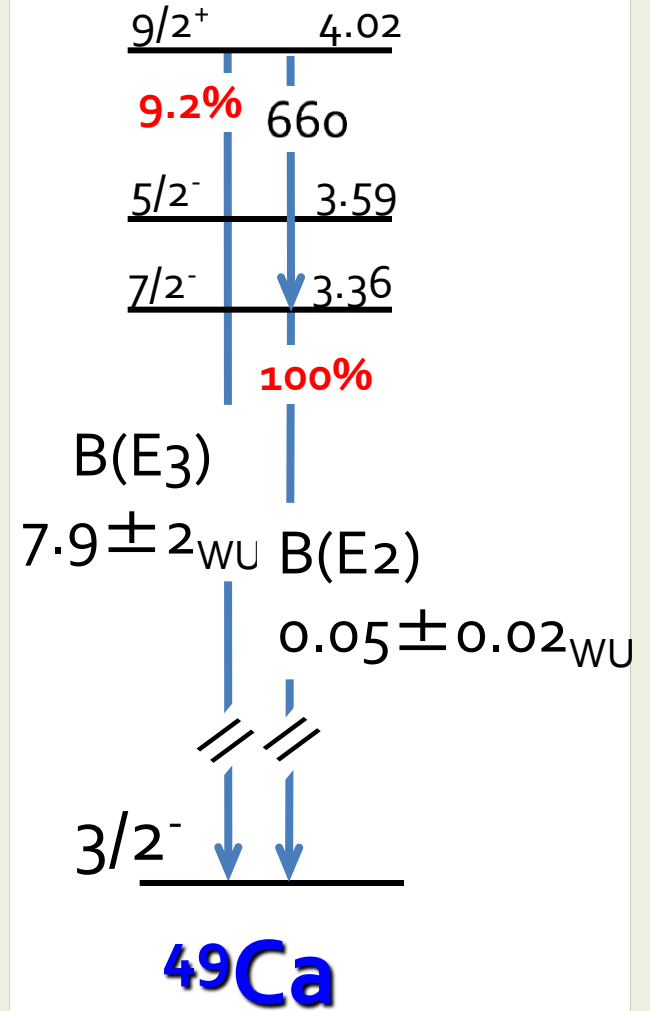
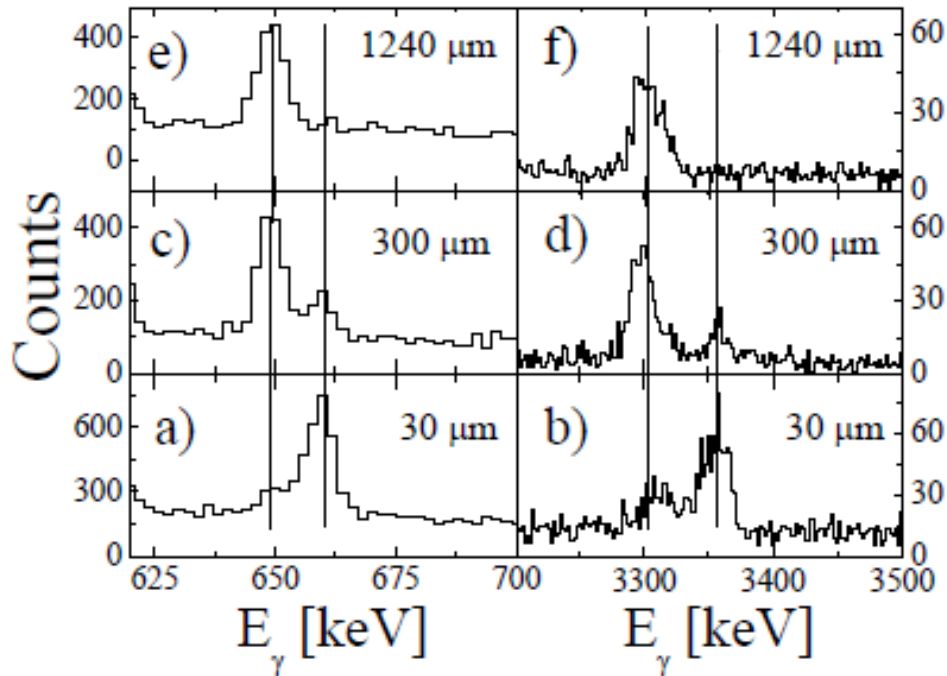
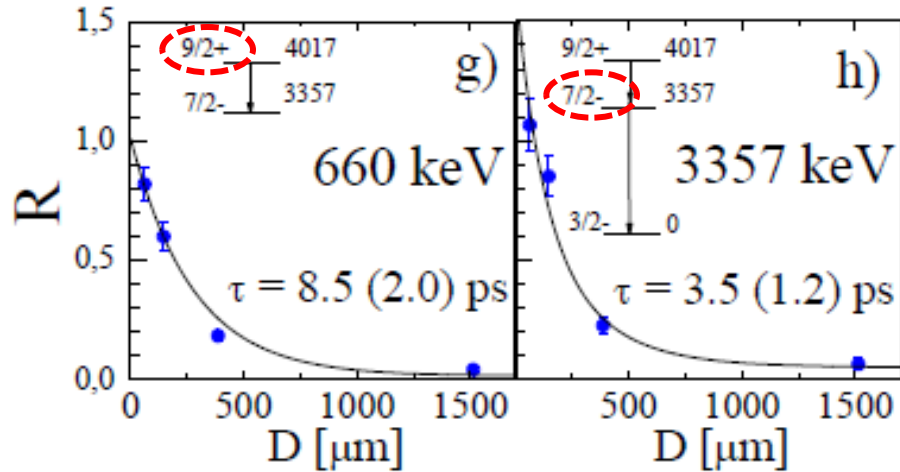

Branching from  
R. Broda thick target exp.

# Interpretation of $^{49}\text{Ca}$

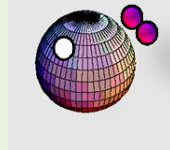
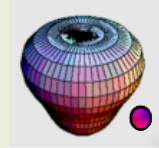
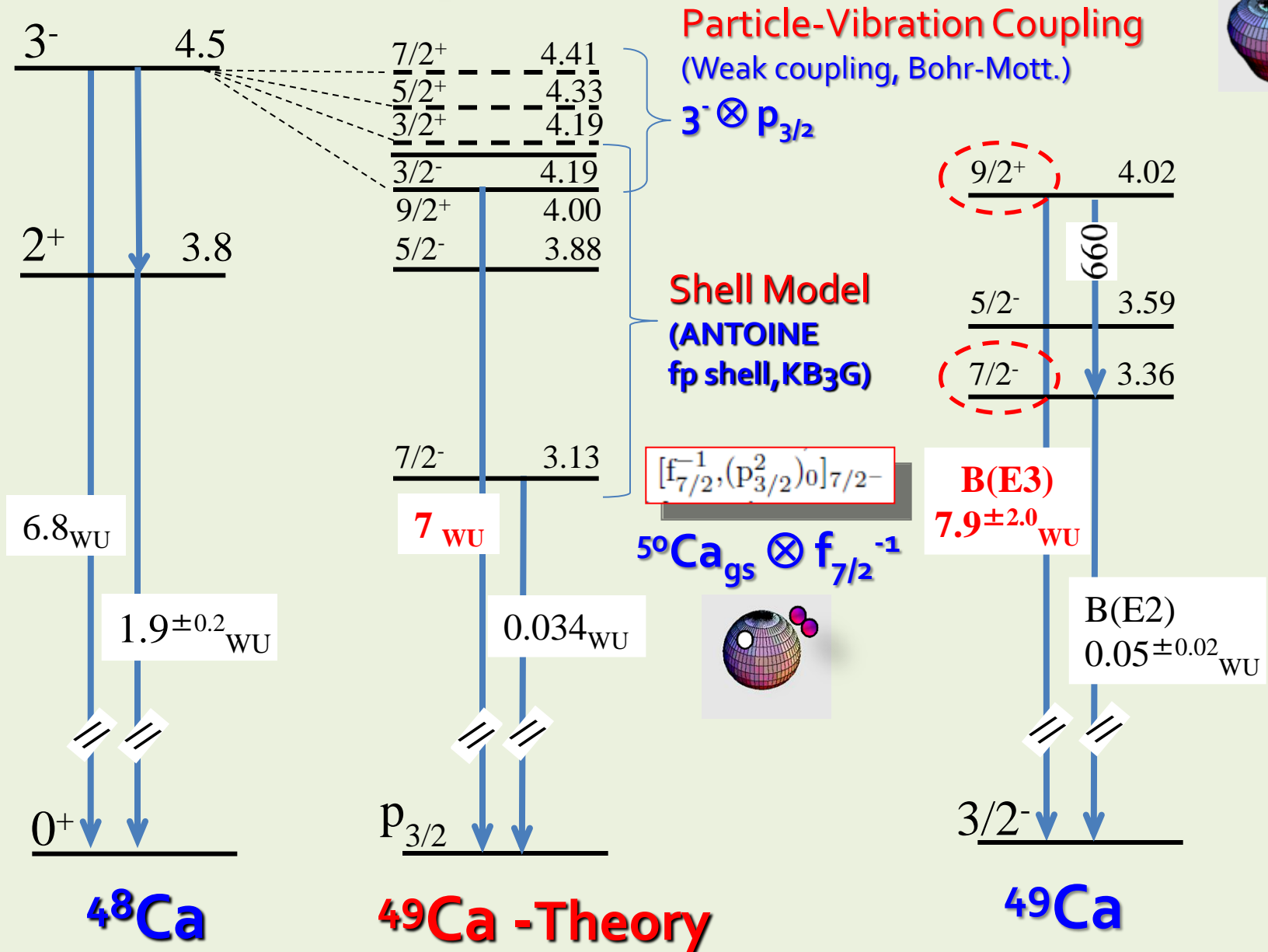

# The case of $^{47}\text{Ca}$

R. Broda, *J.Phys.G32(2006)R151*  
MNT & Thick target data

tentative

$I^\pi$

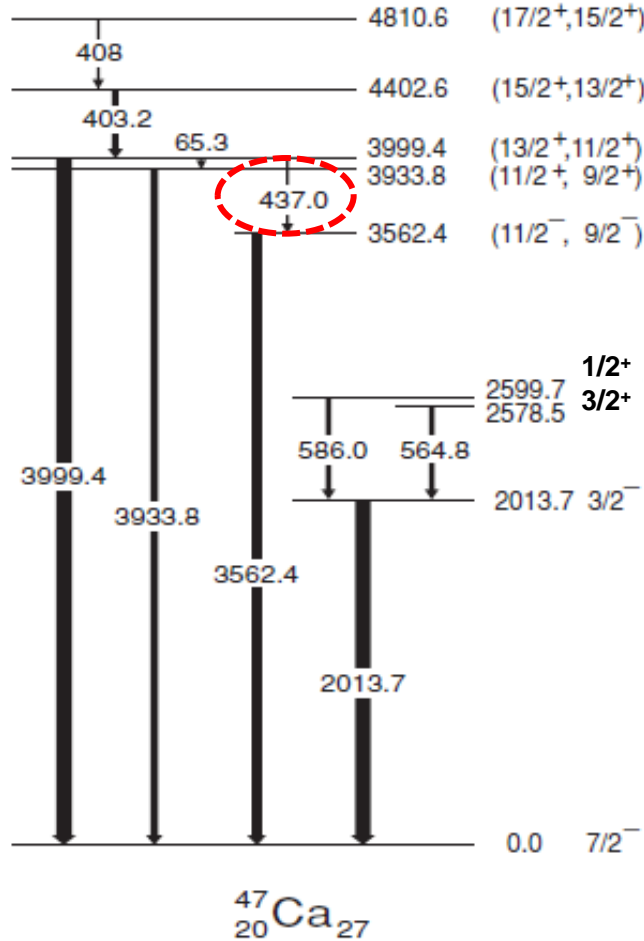

$3^- \otimes f_{7/2}^{-1}$   
???

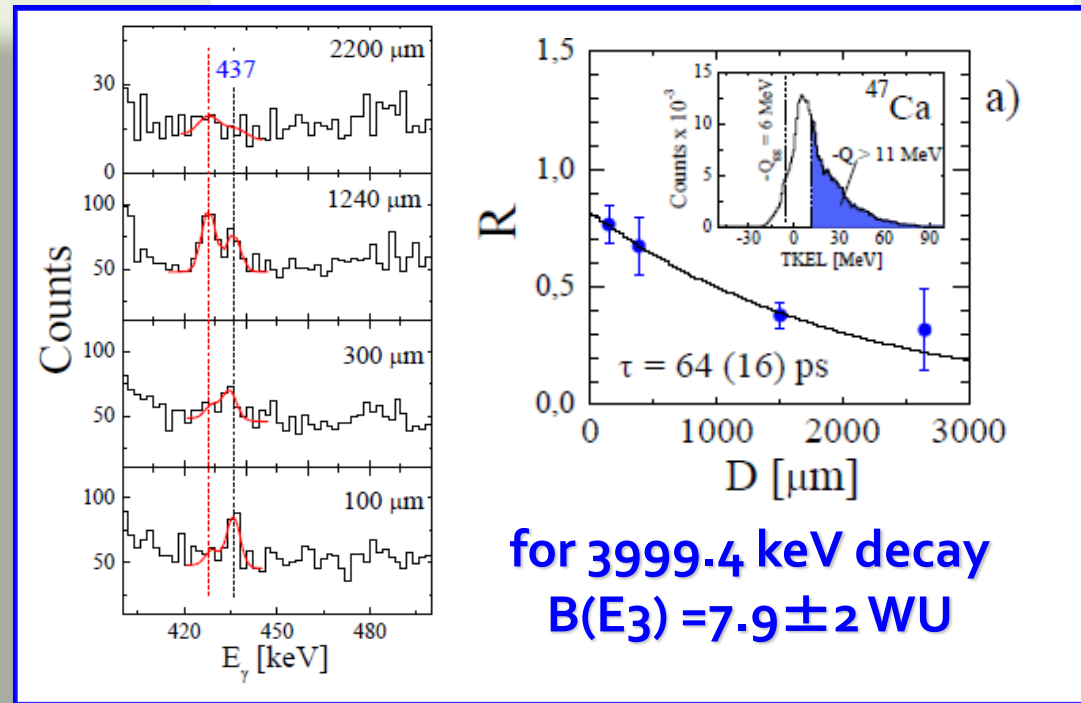
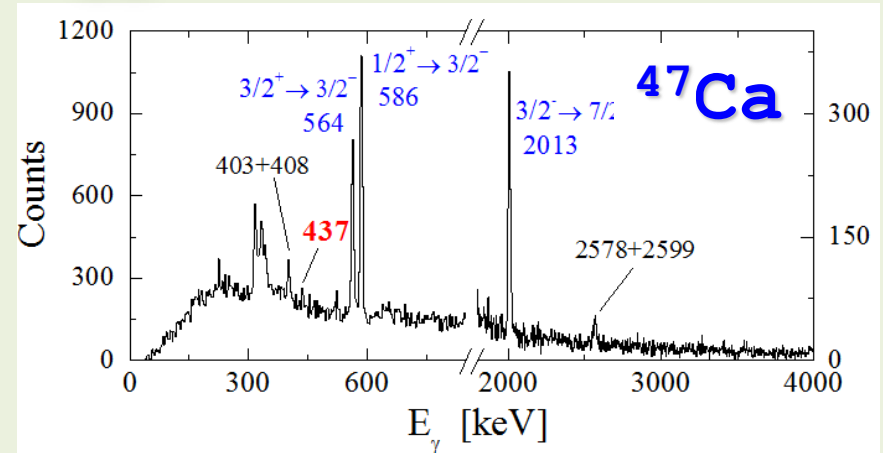

Hole-Vibration Coupling Model : multiplet of states  $\sim 4$  MeV

# Interpretation of $^{47}\text{Ca}$

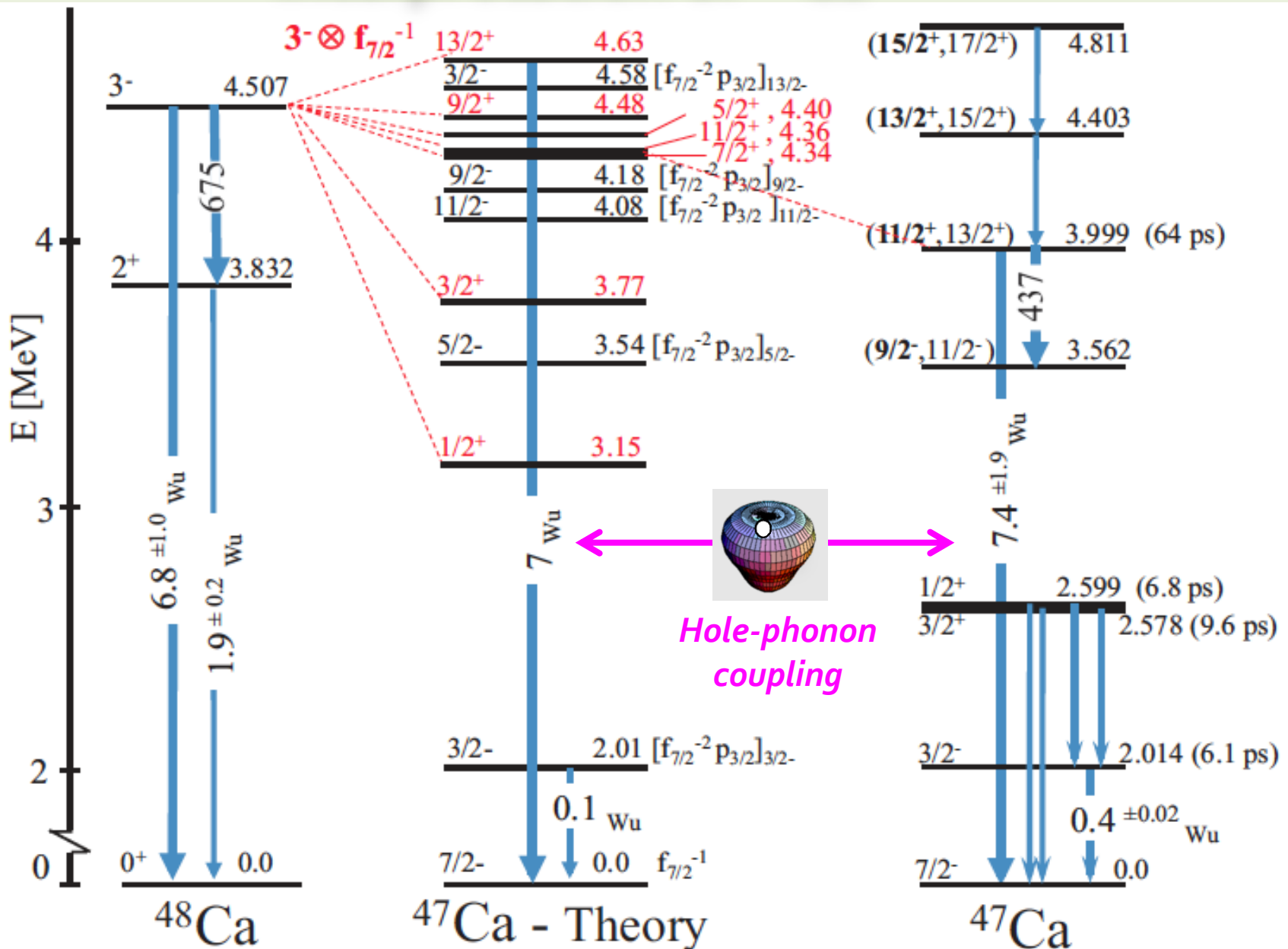

# Work in Progress: $^{65,67}\text{Cu}$

## Study of Particle-Phonon states around Ni isotopes

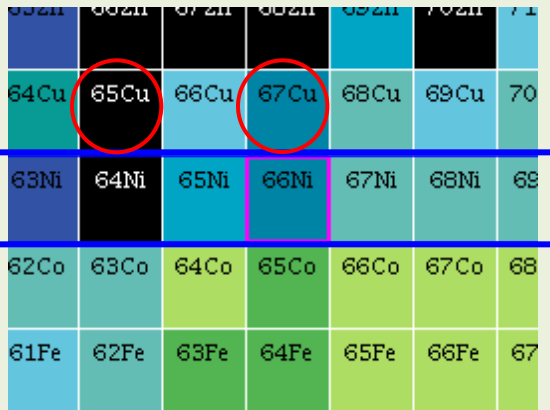

**$^{64,66}\text{Ni}$**

( $Z=28, N=36,38$ )

- Superfluid Core in  $\nu$
- $\pi$  coupling

$$3^- \otimes p_{3/2} \rightarrow [\lambda \otimes j_1]_1$$

Multiplet of States  
 $9/2^+, 7/2^+, 5/2^+, 3/2^+$

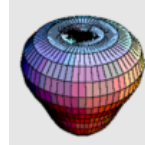
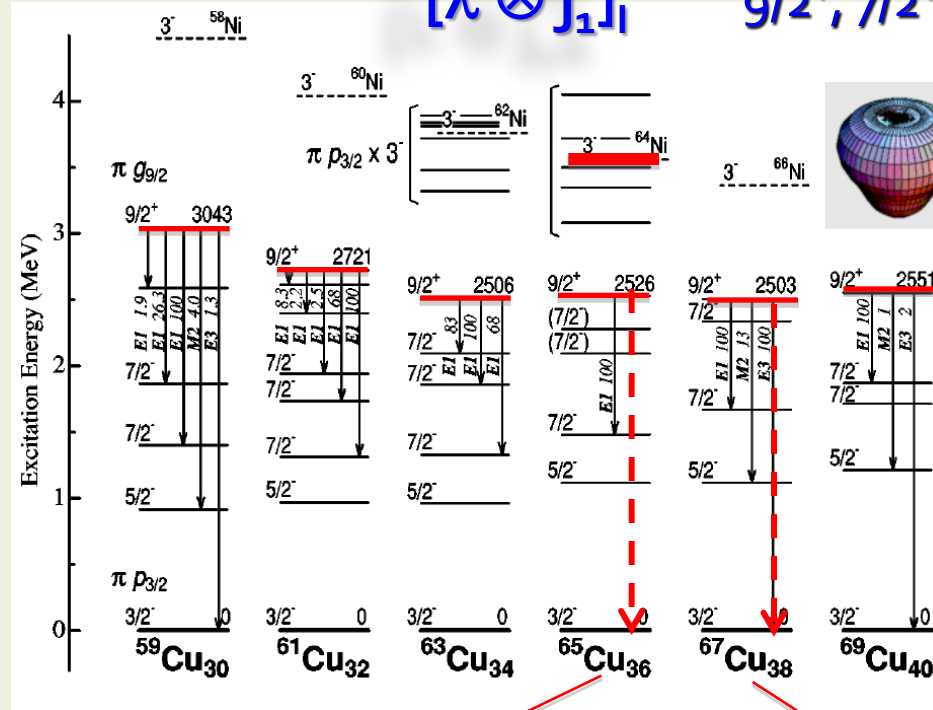

$3^-$   
 $B(E_3) \sim 17 \text{ Wu}$

●  $\pi p_{3/2}^-$

### August 2012 Experiment

$^{64}\text{Ni}(^7\text{Li}, \alpha)^{65}\text{Cu}$

Tandem-Bucarest

S. Leoni et al.  
FAST TIMING  
 $B(E_3) \sim ??? \text{ Wu}$

### Existing Data

$^{64}\text{Ni}(\alpha, p)^{67}\text{Cu}$

N. Marginean et al.  
FAST TIMING  
 $\tau(9/2^+) \sim 150 \text{ ps}$   
 $B(E_3) \sim 17(2) \text{ Wu}$

# Theoretical Interpretation

(S. Bottoni, G. Bocchi, G. Colò, PF. Bortignon)

## Single Particle $\pi$ Levels

$^{64,66}\text{Ni}$  ( $Z=28, N=36,38$ )

Superfluid Core

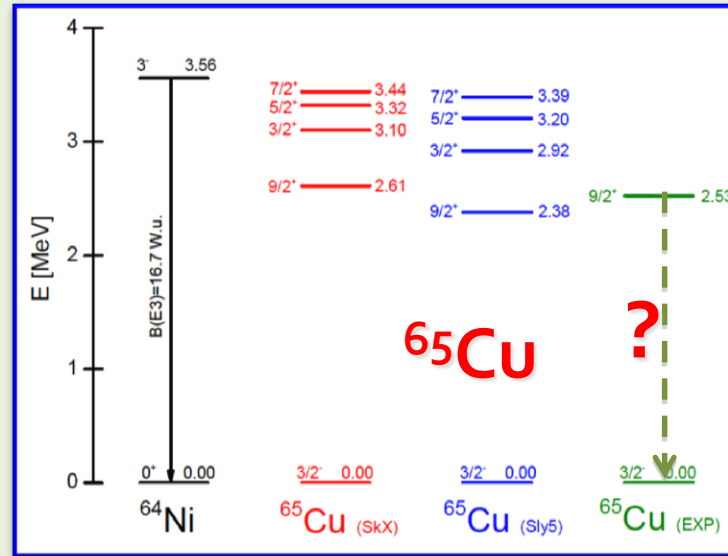
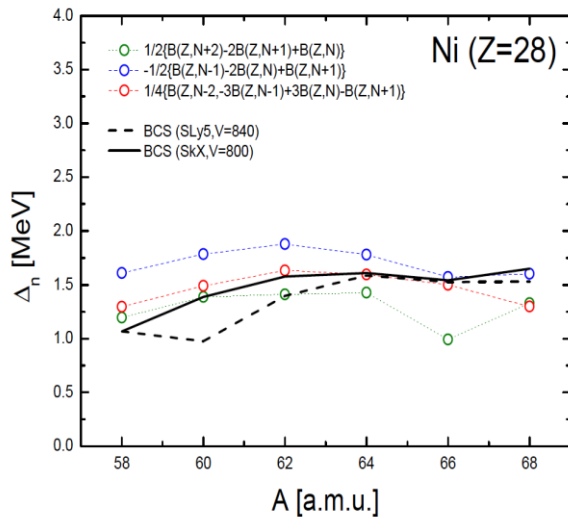
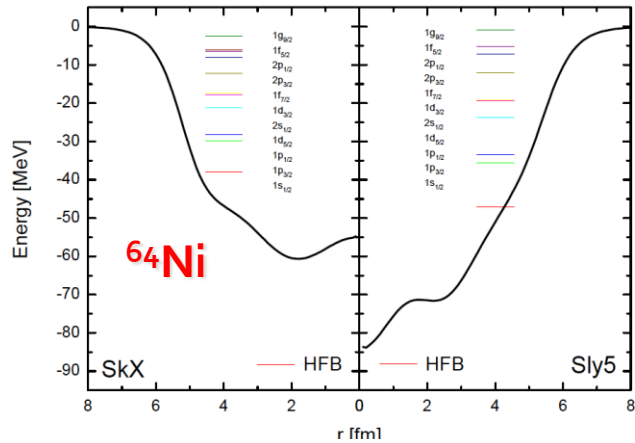

Coupling with proton

$3^- \otimes p_{3/2}$

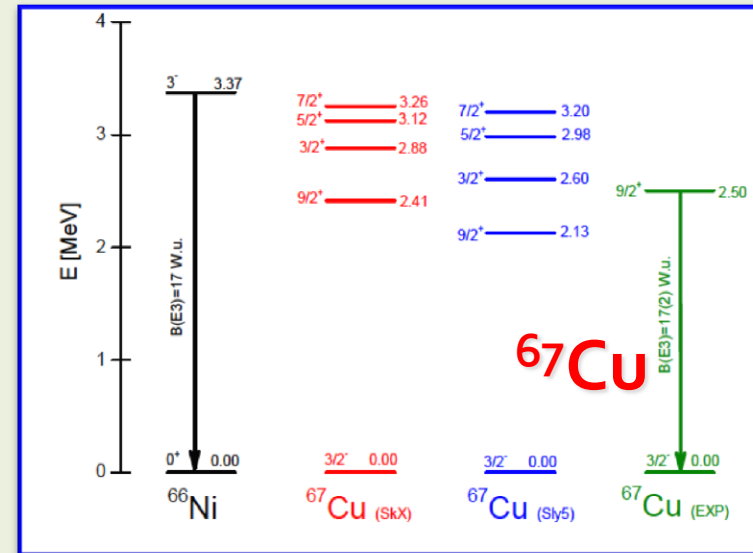

→ Good Candidates for Particle-Phonon Coupled states

# Perspectives with RIB

## $\gamma$ spectroscopy around $^{132}\text{Sn}$ with HI transfer reactions

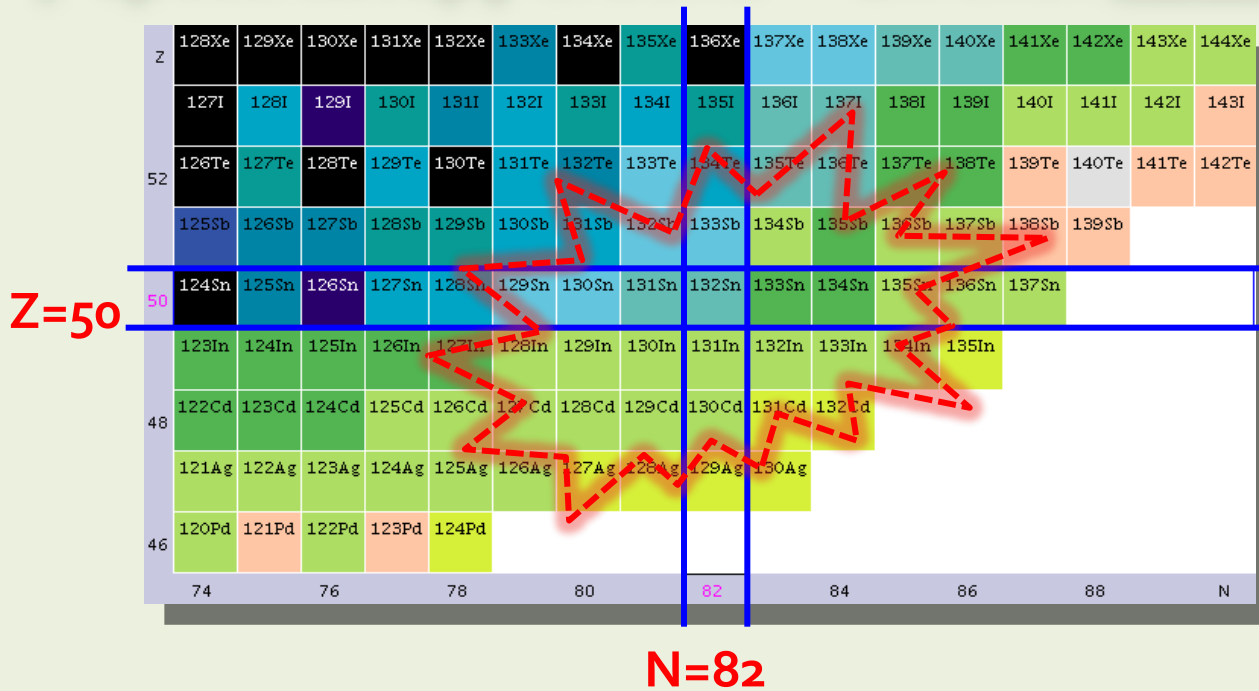

**STUDY OF**

- Single particle states
- particle-phonon couplings
- high spins

**$I\pi, B(E\lambda)$**

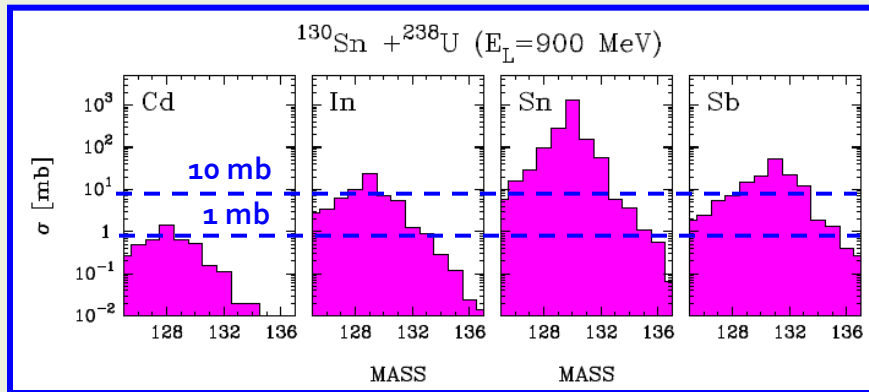

*GRAZING calculations*  
*Conservative estimates for more than 1 nucleon transfer*

## SPES Beams Legnaro-RIB

<b><math>^{130}\text{Sn}</math></b> $1.6 \cdot 10^8$	$^{131}\text{Sn}$ $6.8 \cdot 10^7$	$^{132}\text{Sn}$ $3.1 \cdot 10^7$	$^{133}\text{Sn}$ $2.8 \cdot 10^6$	$^{134}\text{Sn}$ $5 \cdot 10^5$
$^{129}\text{In}$ $1.1 \cdot 10^5$	$^{130}\text{In}$ $1.5 \cdot 10^4$	$^{131}\text{In}$ $2.8 \cdot 10^3$	$^{132}\text{In}$ $1.9 \cdot 10^3$	$^{133}\text{In}$ -
$^{128}\text{Cd}$ $2.9 \cdot 10^3$	$^{129}\text{Cd}$ $2.5 \cdot 10^2$	$^{130}\text{Cd}$ -		

# $^{131}\text{In}$ – proton hole states

Sb	131Sb	132Sb	133Sb	134Sb	135Sb	136Sb
Sn	130Sn	131Sn	132Sn	133Sn	134Sn	136Sn
In	129In	130In	131In	132In	133In	135In
Cd	128Cd	129Cd	130Cd	131Cd	132Cd	134Cd

E [MeV]

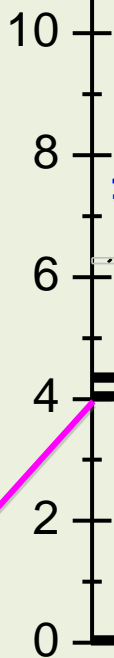

EXP

HF-Skx

$B(E2)$   
7.2 Wu

$B(E3)$   
> 7 Wu

pure  
hole states

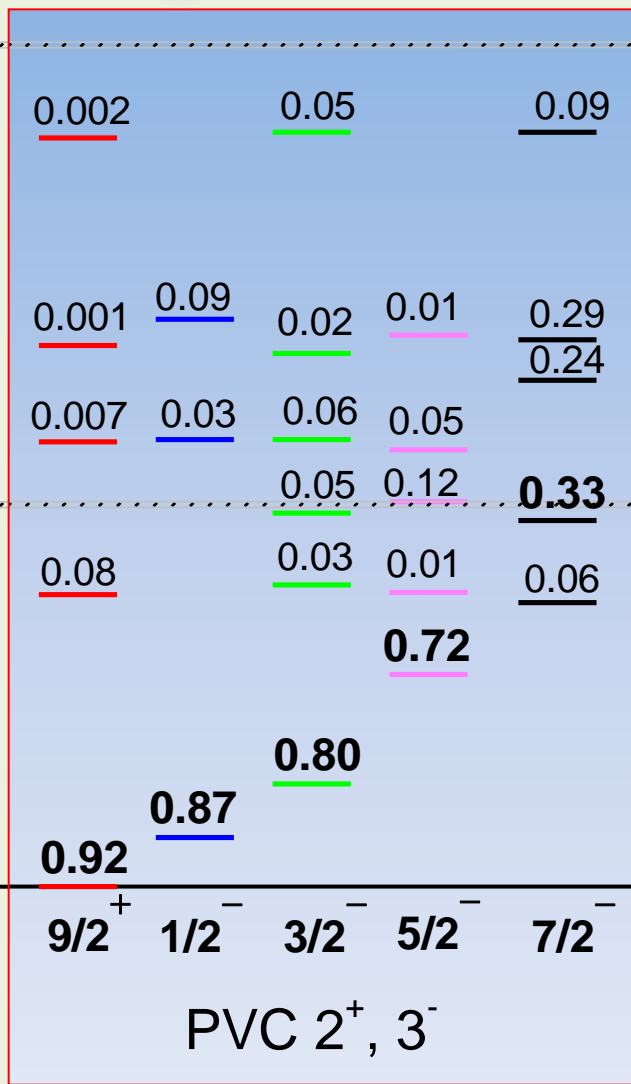

PVC 2<sup>+</sup>, 3<sup>-</sup>

EXP

S<sub>p</sub>

S<sub>n</sub>

(17/2<sup>+</sup>) 630 ns  
(21/2<sup>+</sup>) 0.3 s

(5/2)

(3/2)

(1/2<sup>-</sup>) 0.3 s

(9/2<sup>+</sup>)

J<sup>π</sup>

# Conclusions

## + **FOCUS on Particle-Phonon Coupled States:**

*Building block of anharmonicity of vibrational spectra  
Quenching of Spectroscopic Factors, ...*

### **→ Research Program in Milano in Exp. and Theory:**

*Systematic study in different mass regions to obtain information on  
Interaction strength, N/Z dependence...*

## + **$\gamma$ -spectroscopy of n-rich nuclei with HEAVY-ION Transfer, Incomplete Fusion Reactions, ...**

*Angular Distribution, Polarization, Lifetime Analysis*

*→ Spin, Parity and Nature of Nuclear State*

**→ Evidence for particle-phonon states in  $^{47,49}\text{Ca}$**

**→ Indication In  $^{65,67}\text{Cu}$ , ...**

## + **Preparatory Work for Radioactive Beam Physics ...**

*Thank You for the Attention*



# Remark for future Analysis:

## High-Precision $W(\theta)$ and Pol Measurements with AGATA

inelastic scattering of light ion beams +  $\gamma$ -decay

$^{17}\text{O}$  @ 20 MeV/A on  $^{208}\text{Pb}$

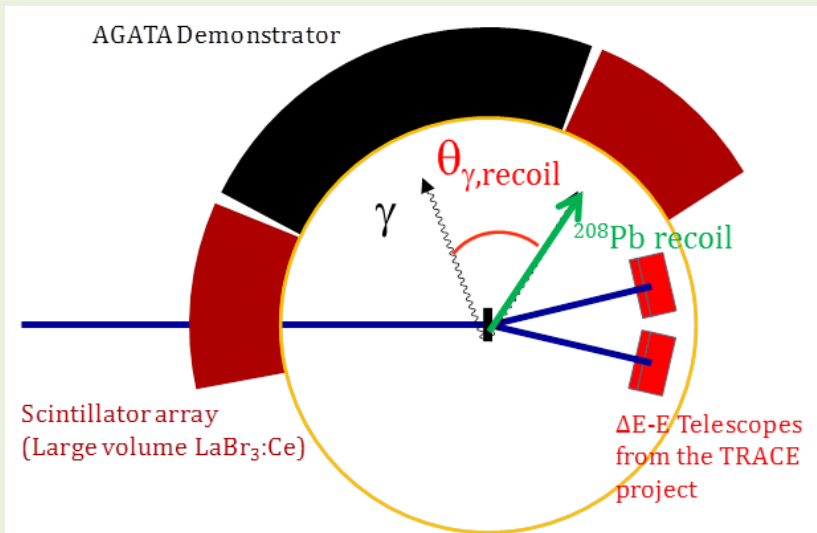

Angular Distribution of  $\gamma$ 's obtained exploiting position sensitivity of AGATA and E- $\Delta$ E Si telescopes (pixel type)

**PRELIMINARY**

F. Crespi, A. Bracco, et al.  
(Milano University)

**$^{208}\text{Pb}$**

