

AGATA

Demonstrator at LNL

Dino Bazzacco
INFN Padova

Symposium Italy- Japan 2012 on Nuclear Physics
Milano 20-23 November 2012

European γ -ray detection systems

TESSA



ESS30

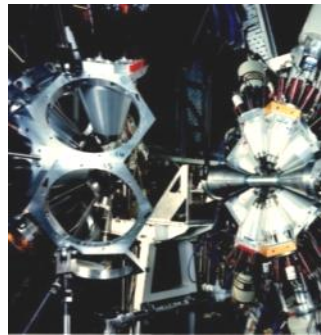

GASP

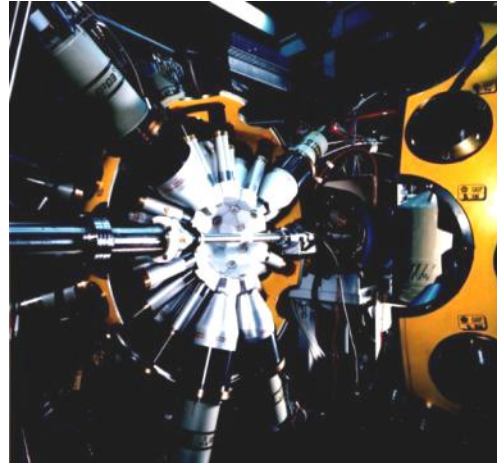

EUROBALL III

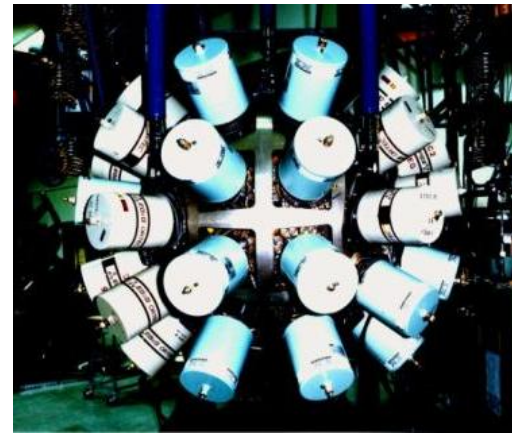

EUROGAM

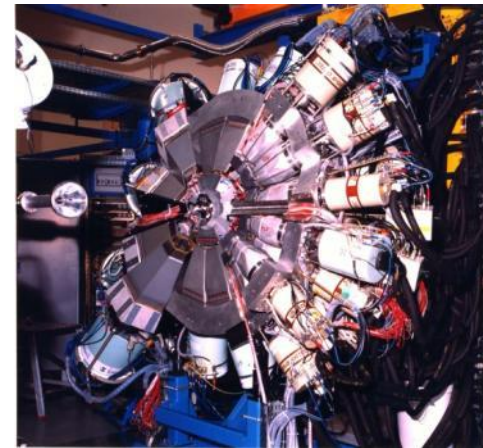

EUROBALL IV

1980

1986

1992

1996



AGATA

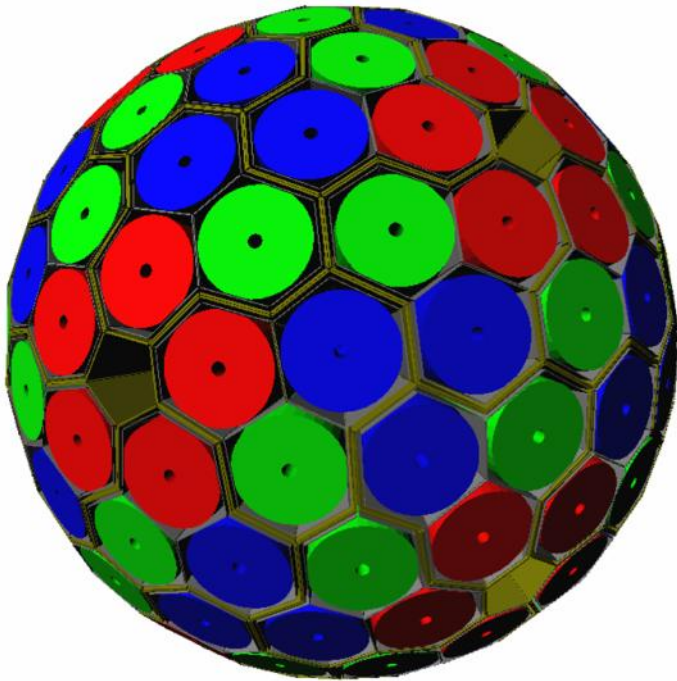
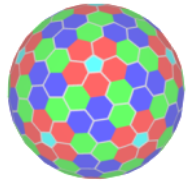

180 hexagonal crystals	3 shapes
60 triple-clusters	all equal
Inner radius (Ge)	23.5 cm
Amount of germanium	362 kg
Solid angle coverage	82 %
36-fold segmentation	6480 segments
Singles rate	~50 kHz
Efficiency:	43% ($M_\gamma=1$) 28% ($M_\gamma=30$)
Peak/Total:	58% ($M_\gamma=1$) 49% ($M_\gamma=30$)

6660 high-resolution digital electronics channels
Detectors operated in position-sensitive mode →
Digital EDAQ + Pulse Shape Analysis + γ -ray Tracking
 Coupling to ancillary detectors for added selectivity

Similar project is GRETA in the US

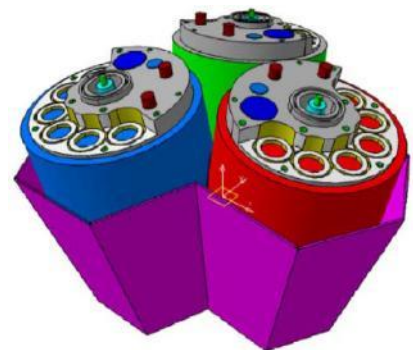

AGATA

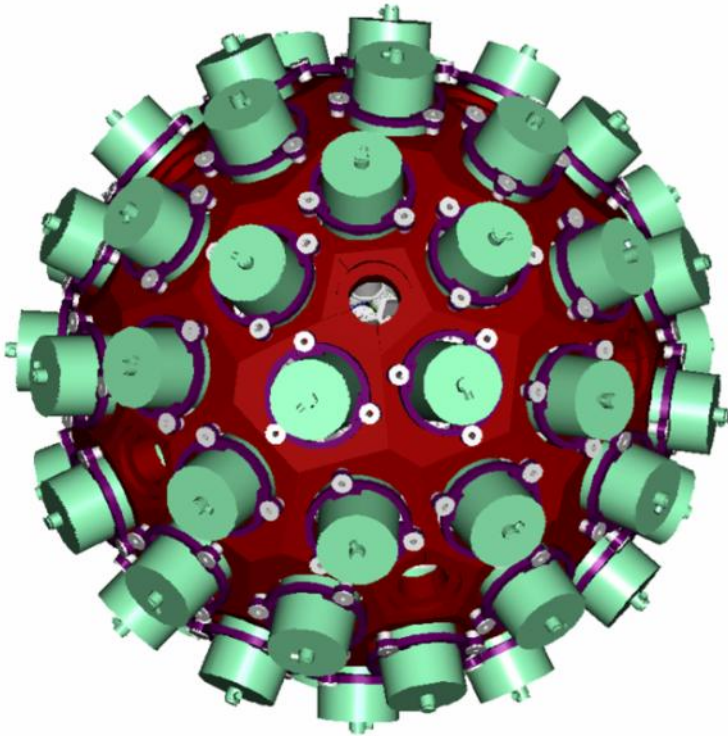
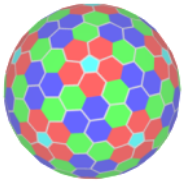

Using the detectors in **position-sensitive mode** will provide very high efficiency and excellent energy resolution, making AGATA ideal for spectroscopic studies of weak channels

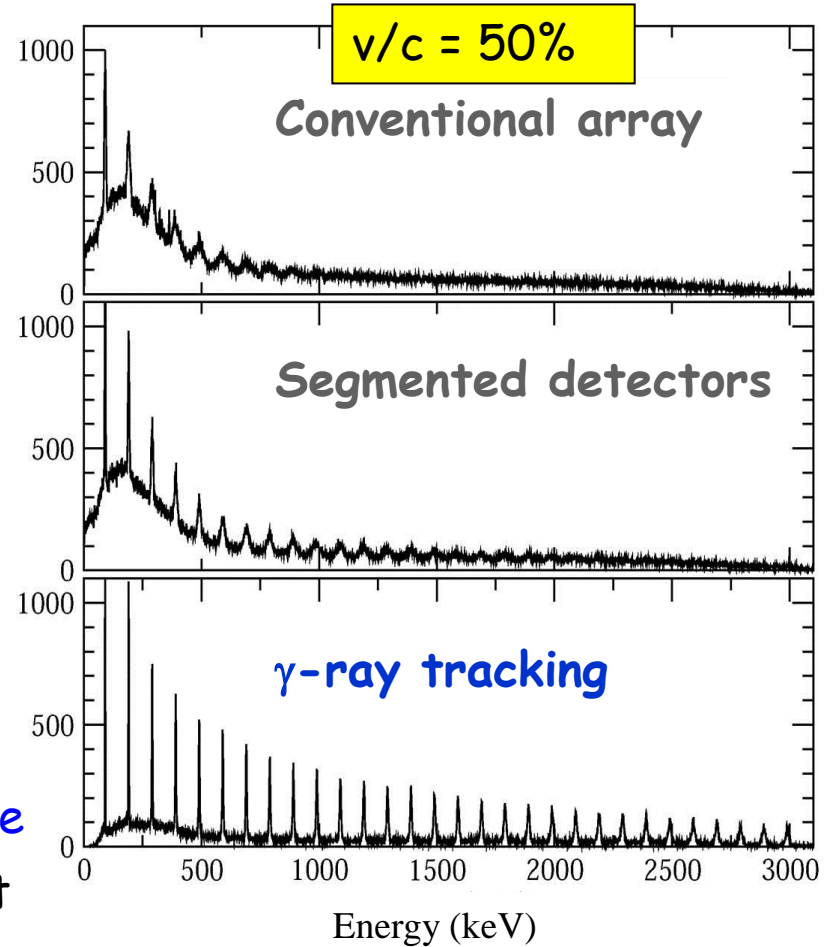

Effective energy resolution maintained at "extreme" v/c

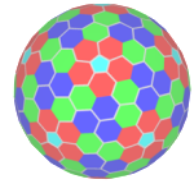

Gamma-ray tracking principle

1

Highly segmented
HPGe detectors

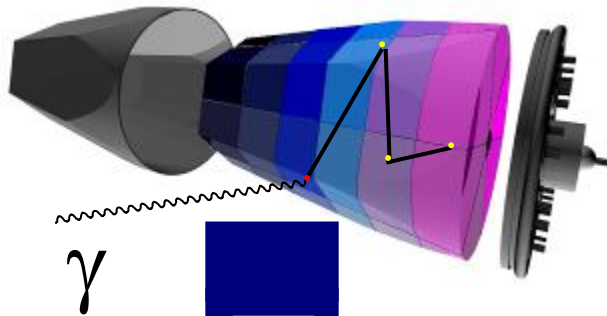

2

Digital electronics
to record and
process segment
signals



Identified
interaction points

$$(x, y, z, E)_i$$

Pulse Shape Analysis
to decompose
recorded waves

3

4

Reconstruction of
scattering sequence from
Compton vertices

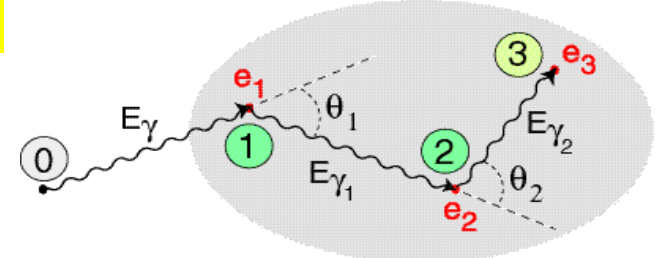

$$E_{\gamma'} = \frac{E_{\gamma}}{1 + \frac{E_{\gamma}}{m_0 c^2} (1 - \cos \theta)}$$

**Reconstructed
gamma-rays**

Pulse Shape Analysis concept

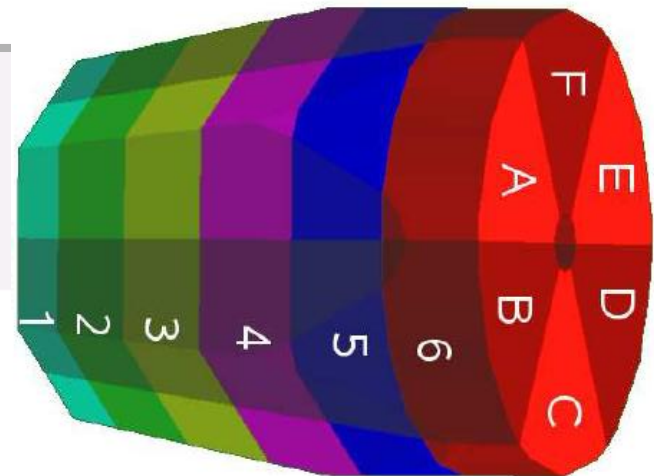
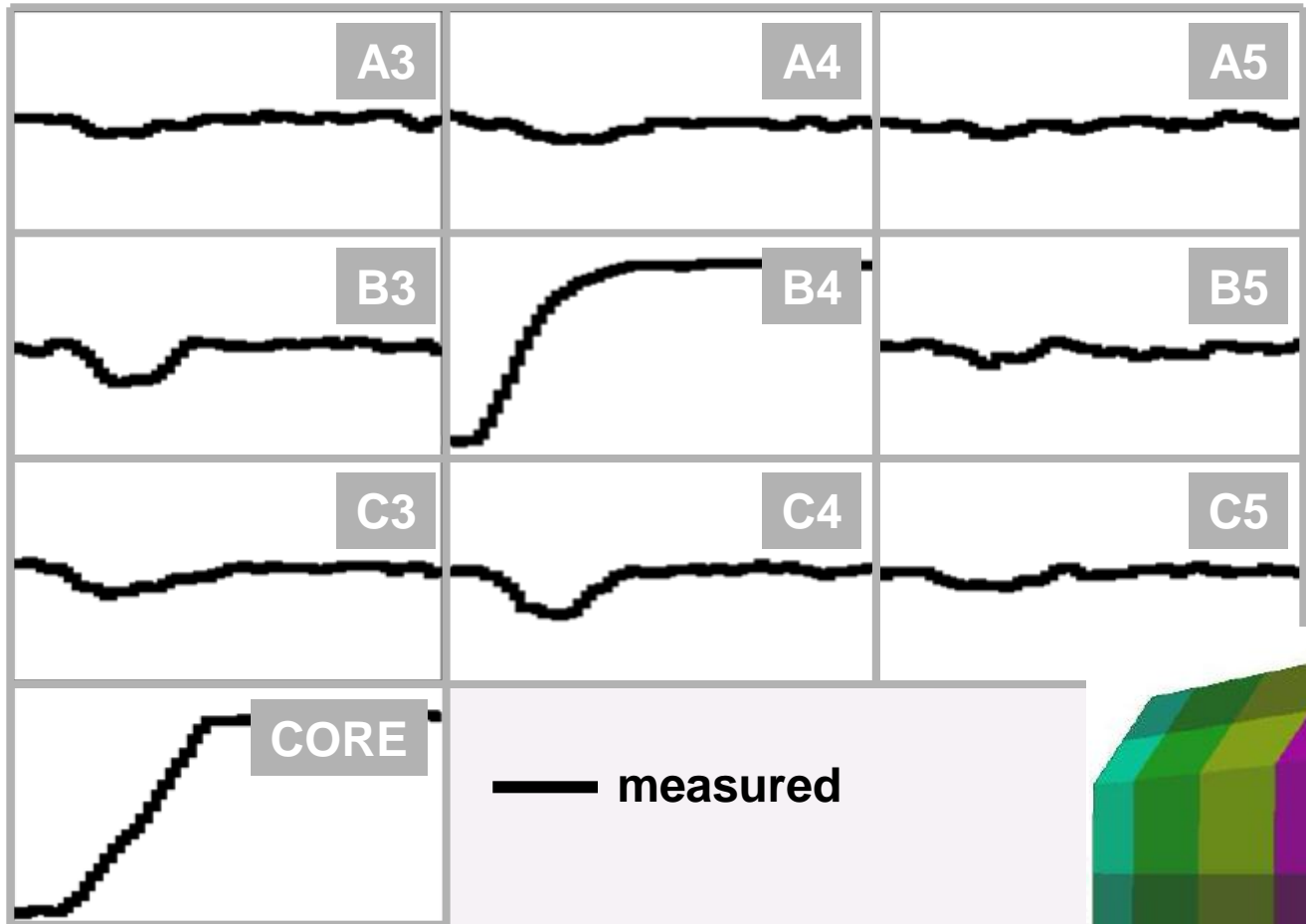

791 keV deposited in segment B4

Pulse Shape Analysis concept

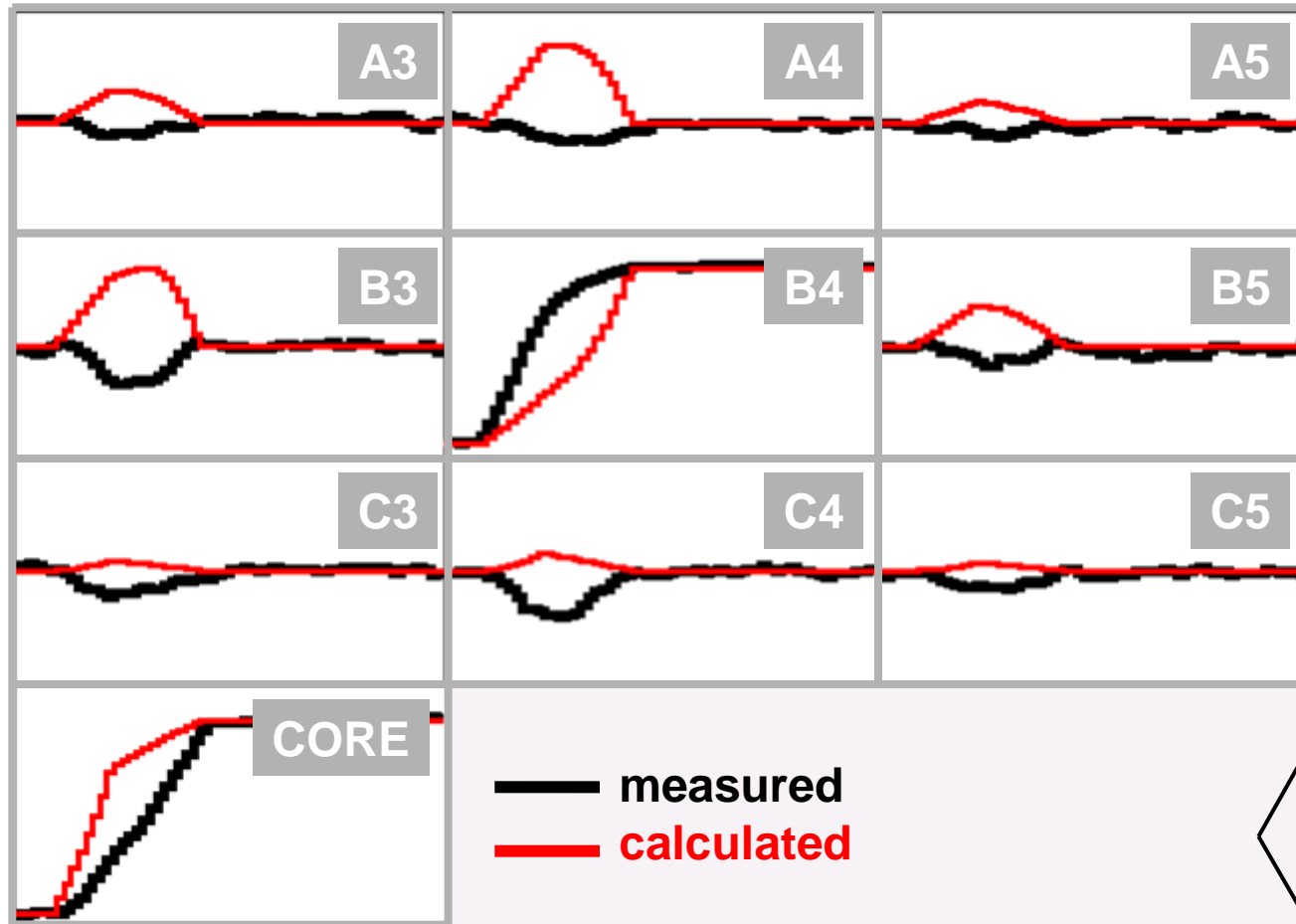

(10, 10, 46)

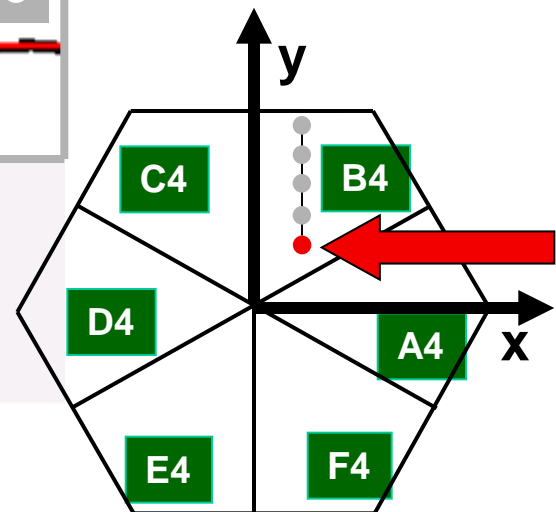

z = 46 mm

791 keV deposited in segment B4

Pulse Shape Analysis concept

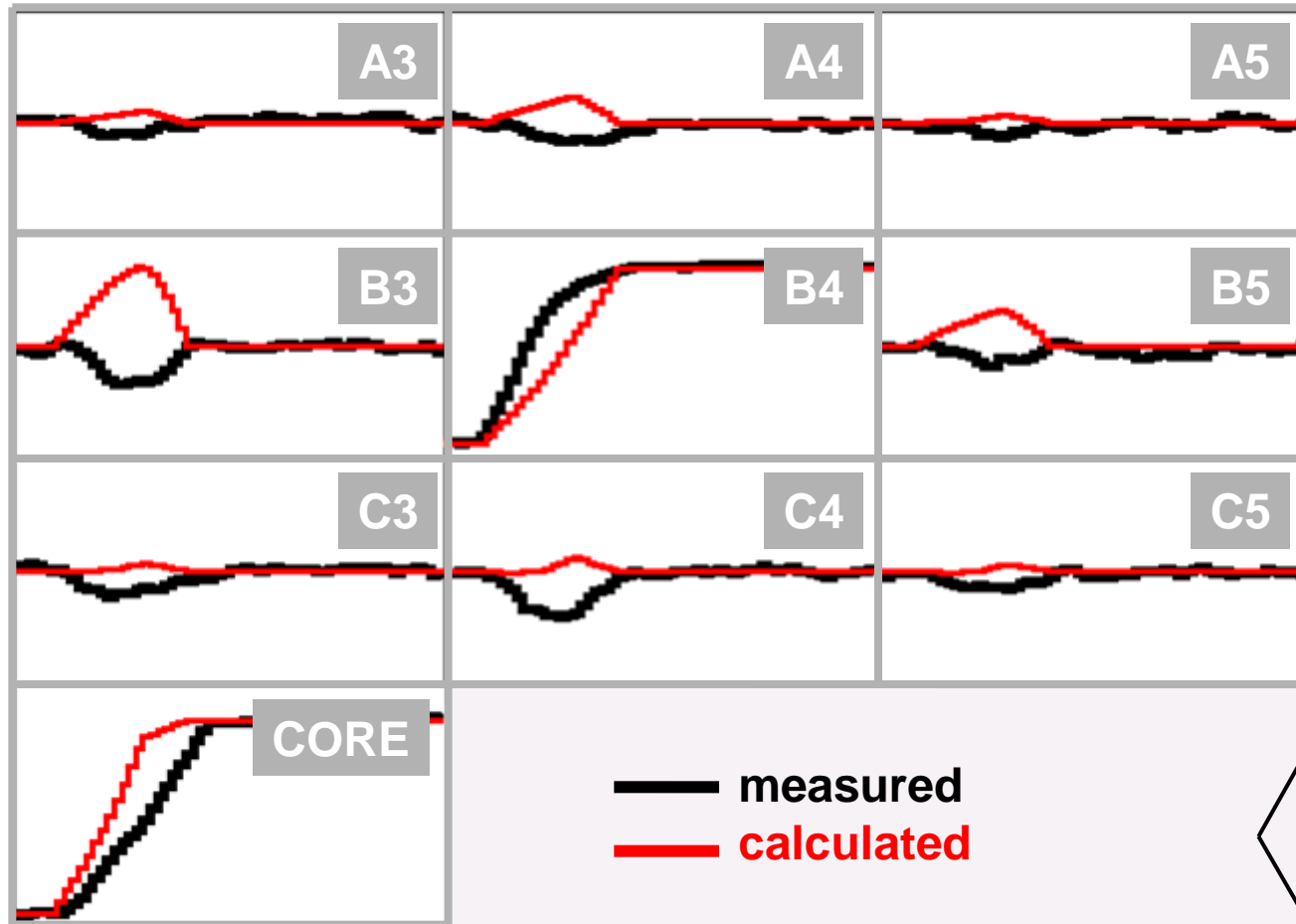

(10, 15, 46)

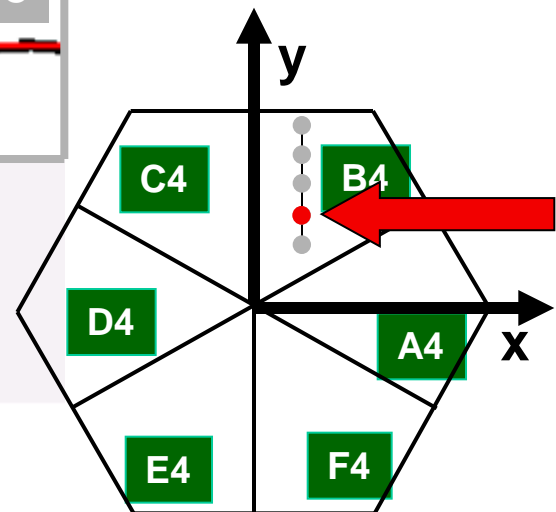

791 keV deposited in segment B4

z = 46 mm

Pulse Shape Analysis concept

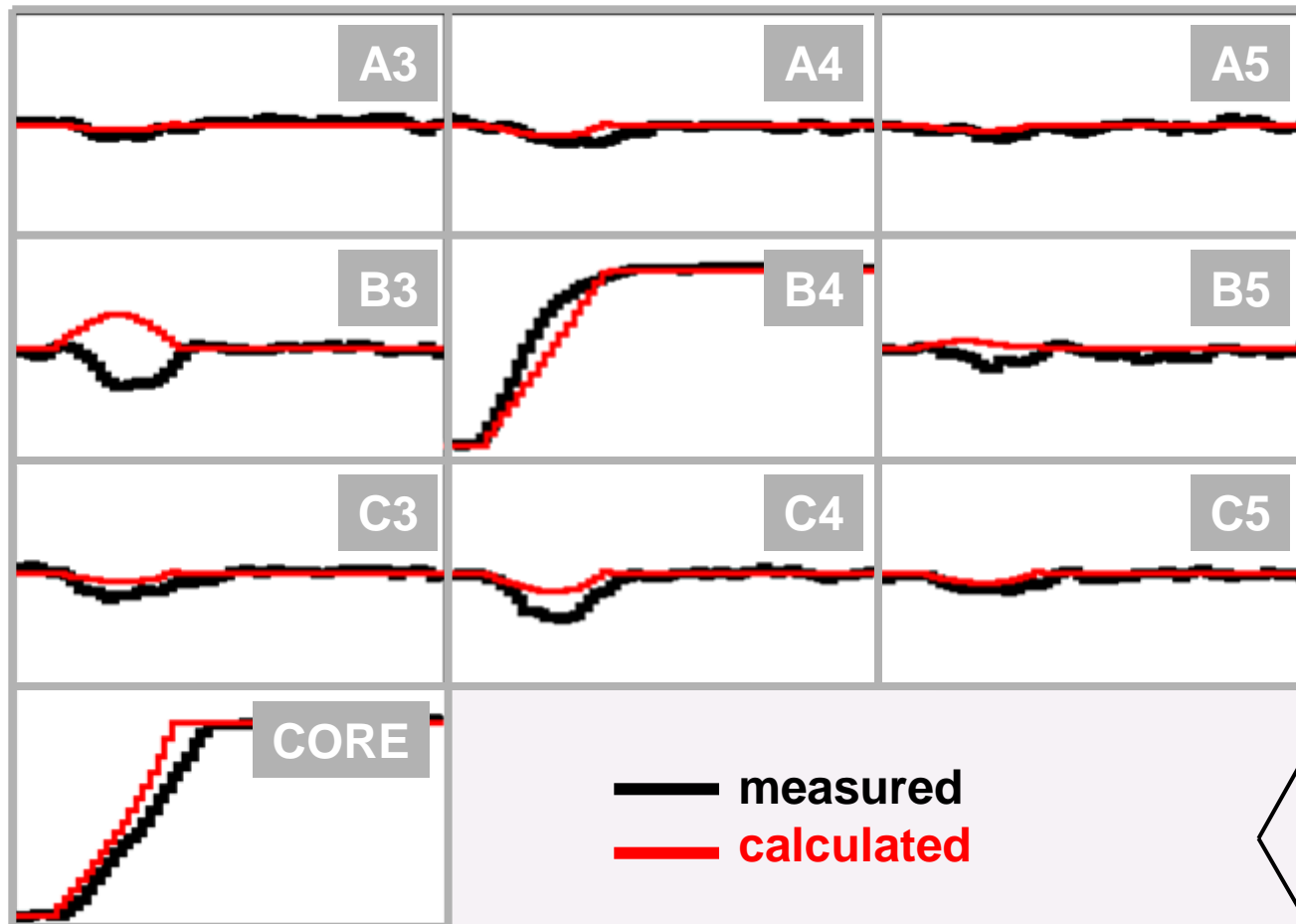

(10, 20, 46)

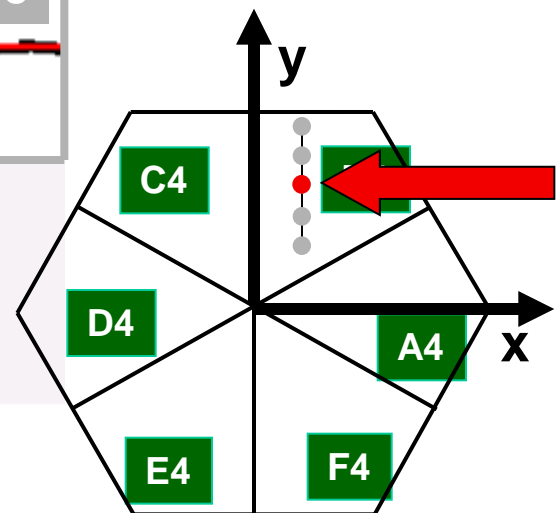

791 keV deposited in segment B4

z = 46 mm

Pulse Shape Analysis concept

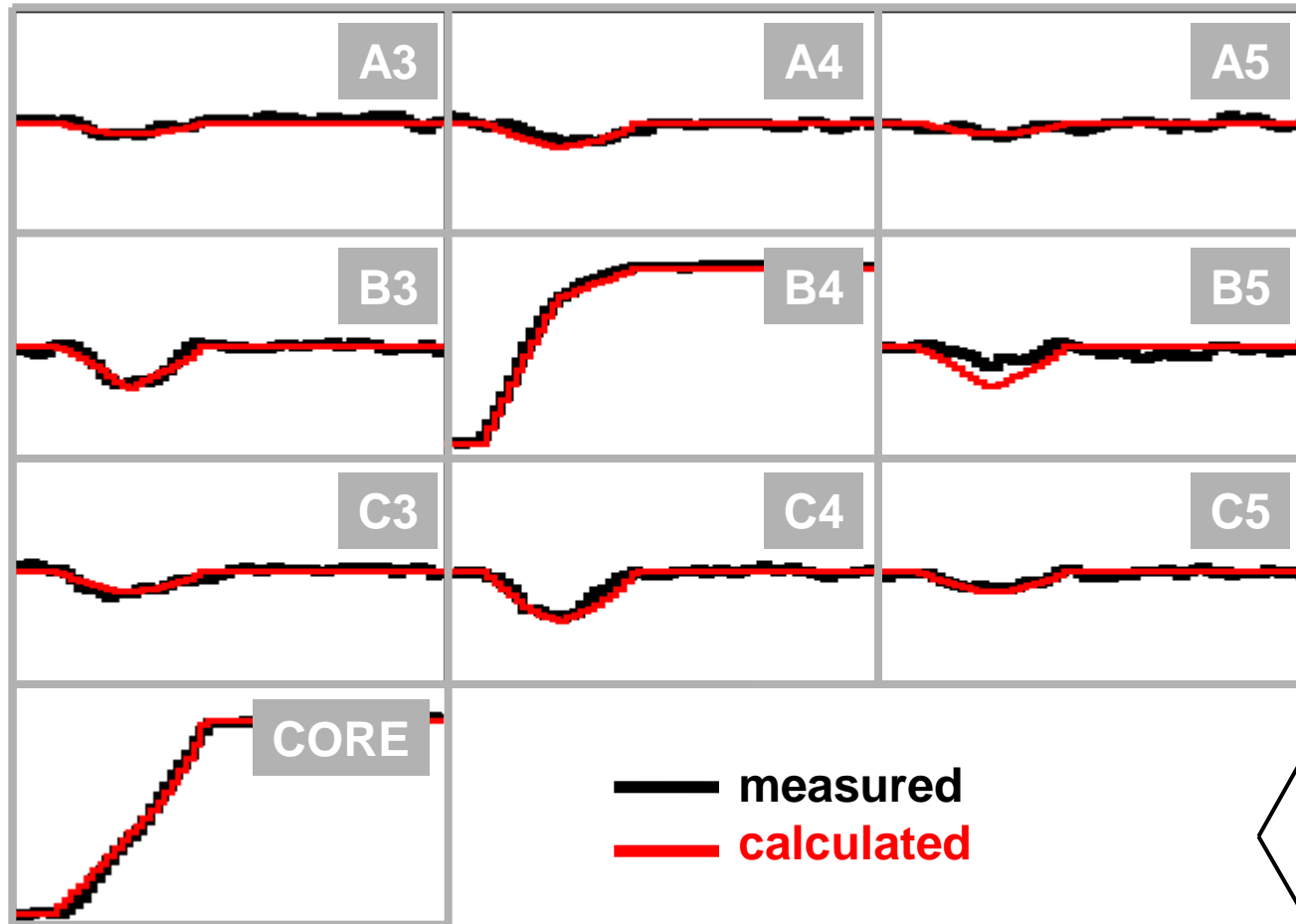

(10, **25**, 46)

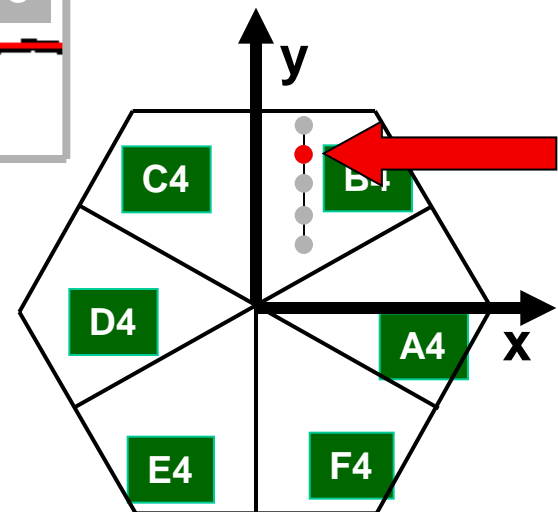

791 keV deposited in segment B4

z = 46 mm

Pulse Shape Analysis concept

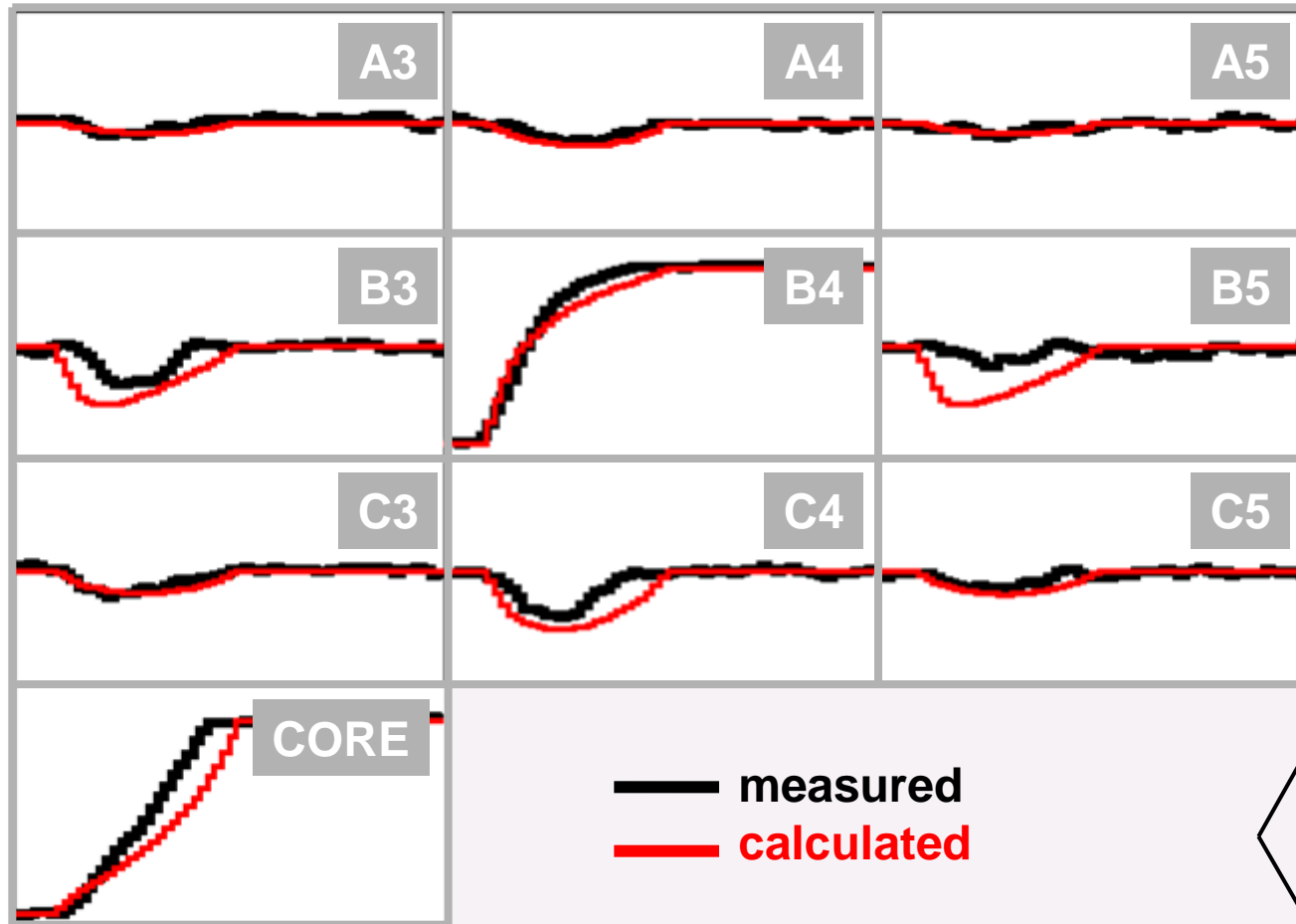

(10, **30**, 46)

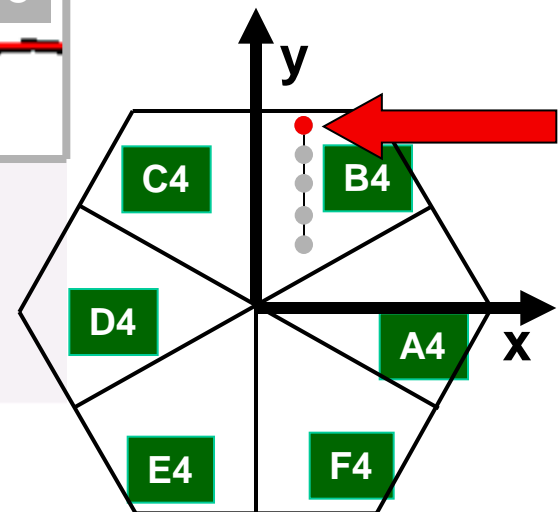

z = 46 mm

791 keV deposited in segment B4

Pulse Shape Analysis concept

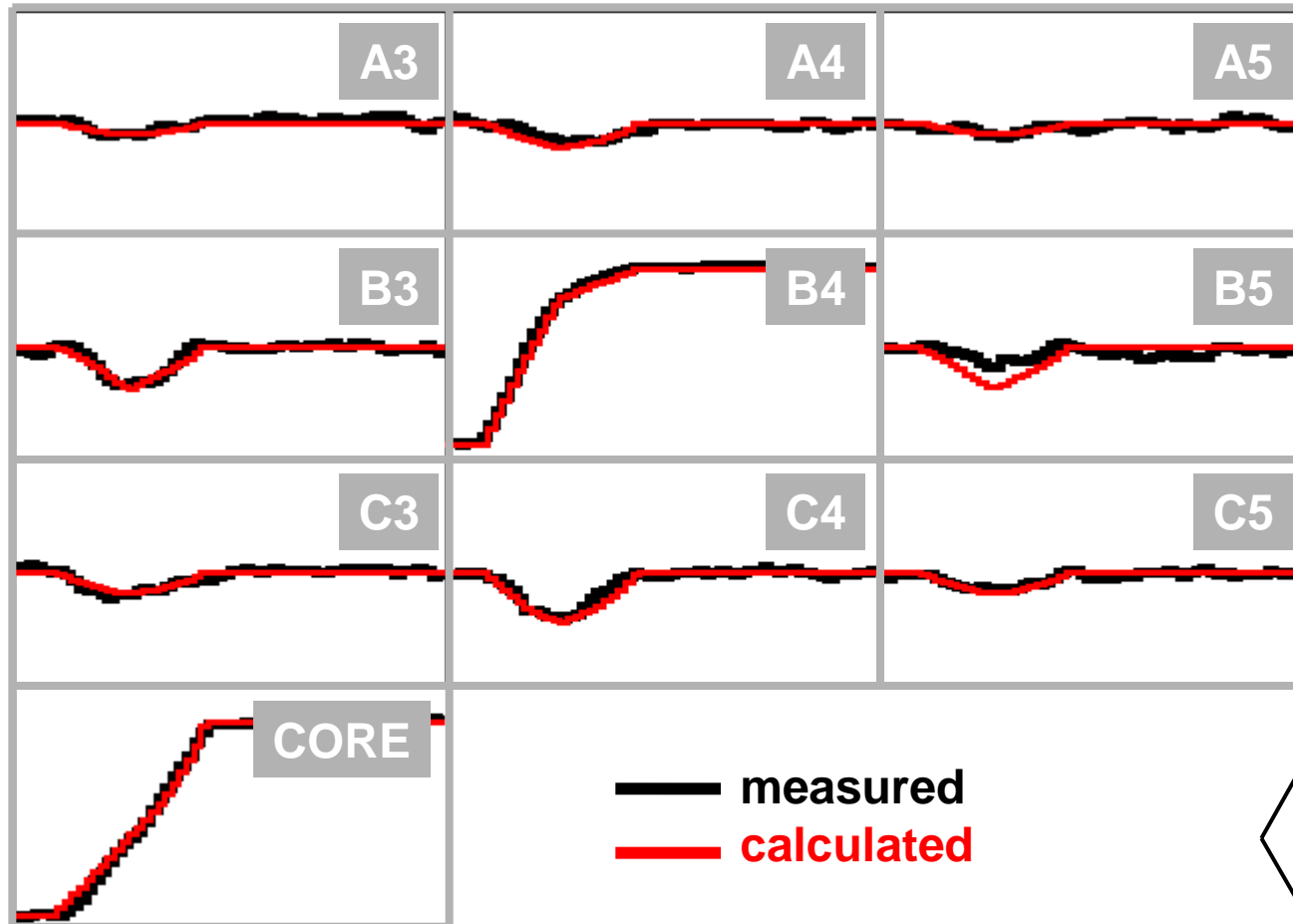

**Result of
Grid Search
Algorithm**

(10, 25, 46)

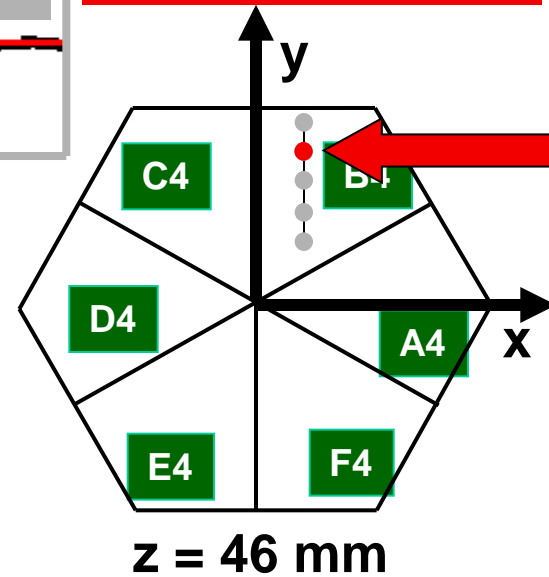

791 keV deposited in segment B4

Examples of signal decomposition

$E_\gamma = 1172 \text{ keV}$

net-charge in A1

x10

A

B

C

D

E

F

CC

$E_\gamma = 1332 \text{ keV}$

net-charge in C3, E1, E3

x10

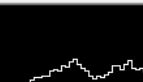
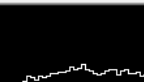
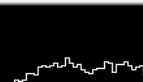
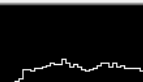
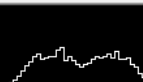
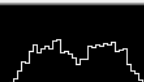
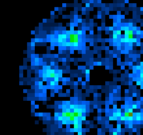
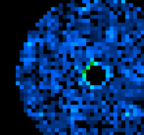
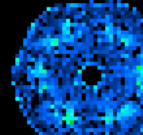
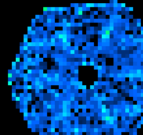
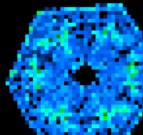
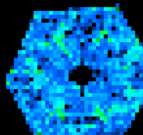
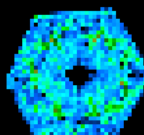
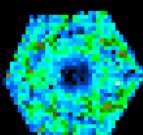
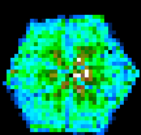

Reconstruction of 0.1÷10 MeV gammas

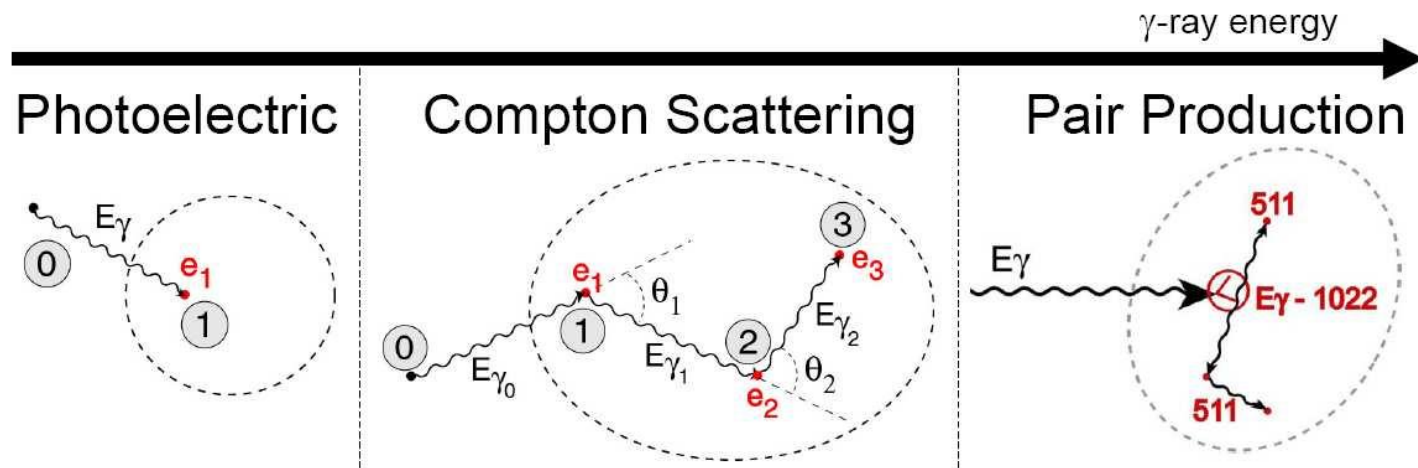

MC simulation of a high-multiplicity event

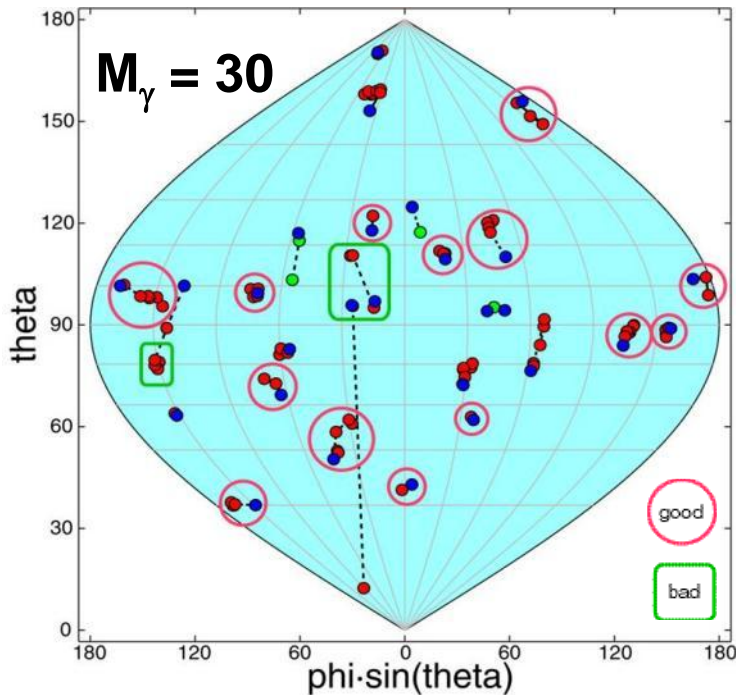

Efficiency depends on position resolution

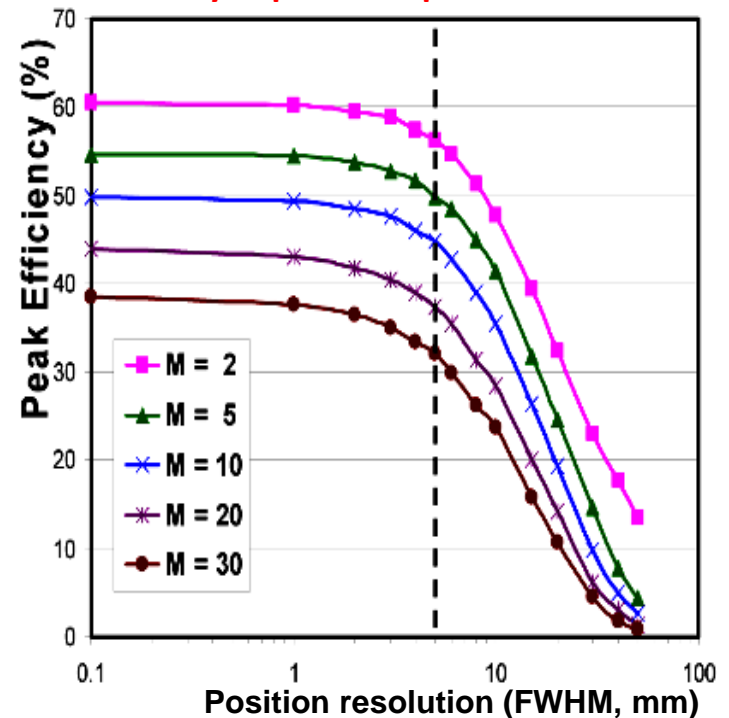

Status after ~10 years of R&D

- ✓ Germanium detectors
- ✓ Pulse Shape Analysis
- ✓ Gamma-ray Tracking
- ✓ AGATA Demonstrator
- ✓ Electronics and DAQ
- ✓ Problems encountered
- ✓ Performance
- ✓ Experiments
- ✓ Evolution

AGATA Detectors

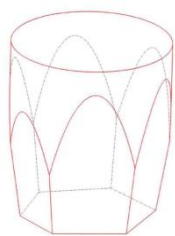
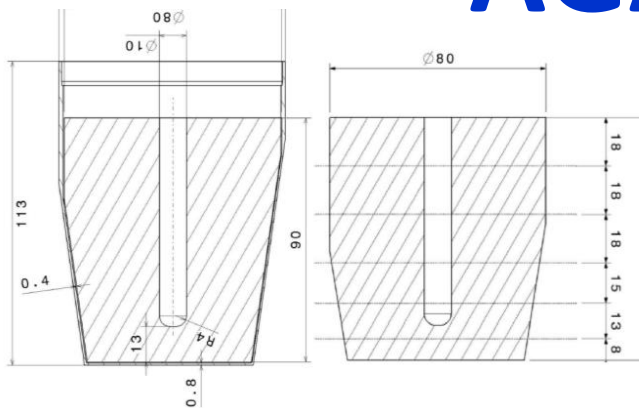

(d) A - red

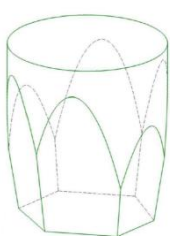

(e) B - green

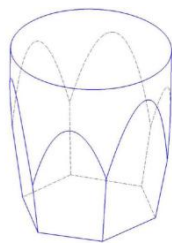

(f) C - blue

Volume ~370 cc Weight ~2 kg
(shapes are volume-equalized to 1%)

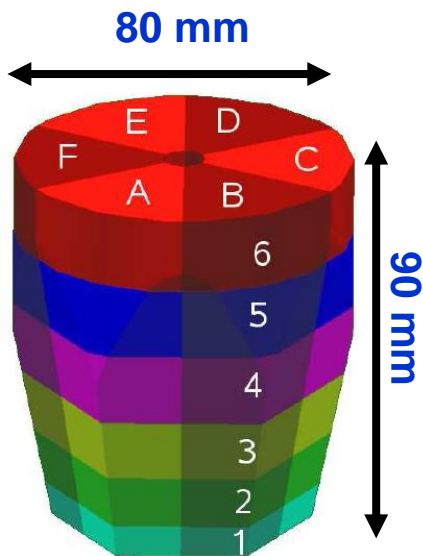

6x6 segmented cathode

Cold FET for all signals

Energy resolution

Core: 2.35 keV

Segments: 2.10 keV

(FWHM @ 1332 keV)

A. Wiens et al. NIM A 618 (2010) 223

D. Lersch et al. NIM A 640(2011) 133

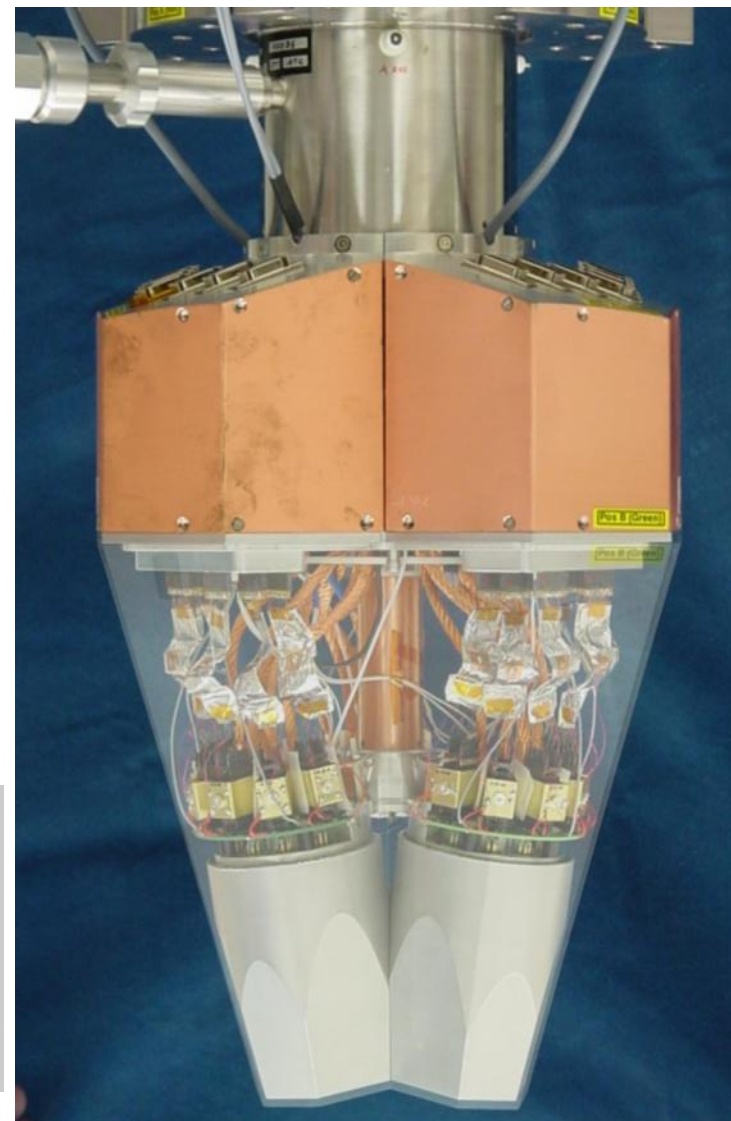

AGATA Asymmetric Triple Cryostat

Manufactured by CTT



AGATA Asymmetric Crystals

Manufactured by Canberra France

AGATA Demonstrator

Objective of the R&D phase 2003-2009
Used for Physics at LNL in 2010-2011

5 asymmetric triple-clusters

15 36-fold segmented crystals

540 segments

555 high-resolution digital-channels

Eff. 3 - 8 % @ $M_\gamma = 1$

Eff. 2 - 4 % @ $M_\gamma = 30$

Real time operation

Pulse Shape Analysis

γ -ray Tracking

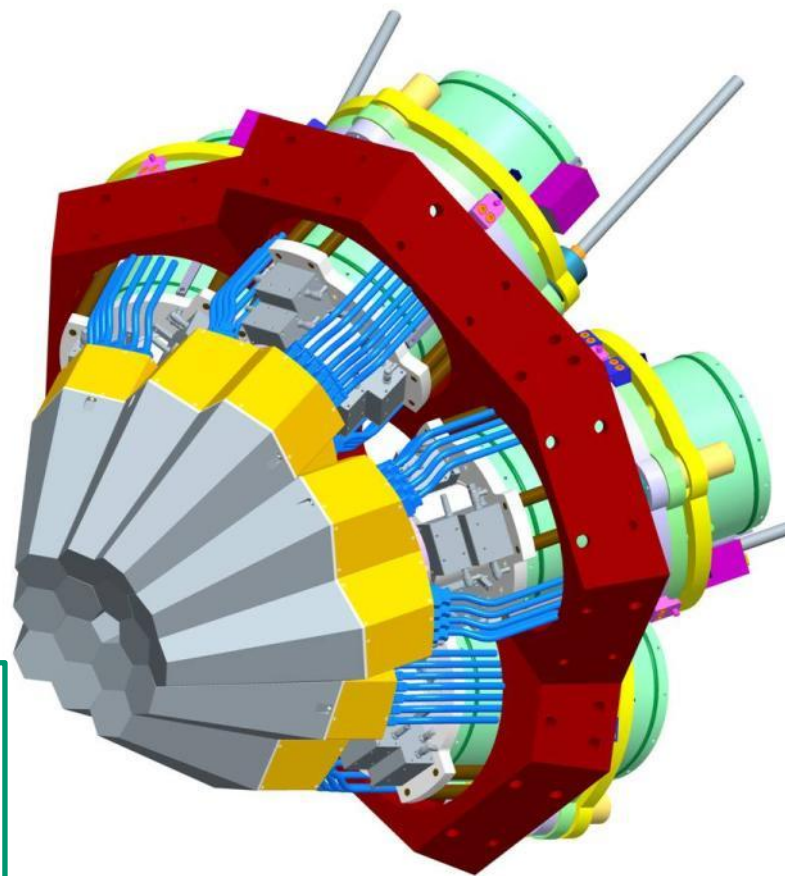

Hosting sites

LNL	→ 2009-2011	(done)
GSI	→ 2012-2013	(midway)
GANIL	→ 2014-2015	(preparation)

AGATA Demonstrator + PRISMA

Infrastructure completed mid 2009, all clusters in place May 2011

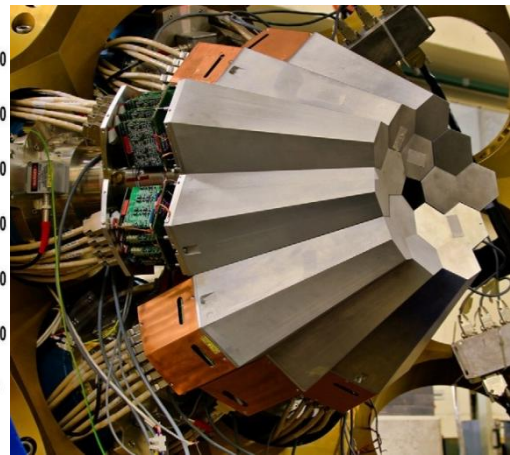
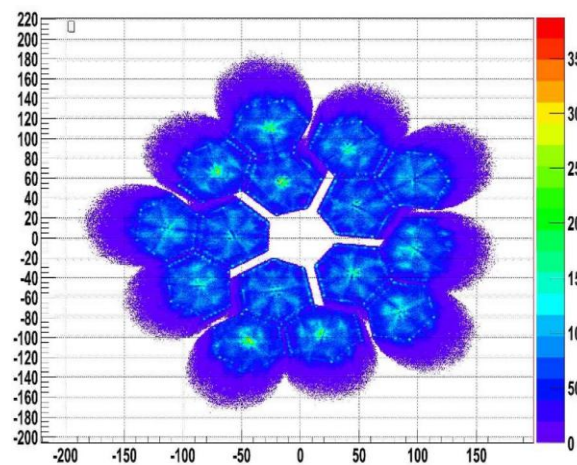
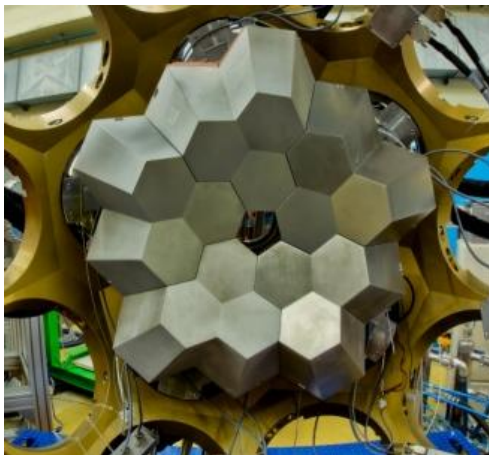
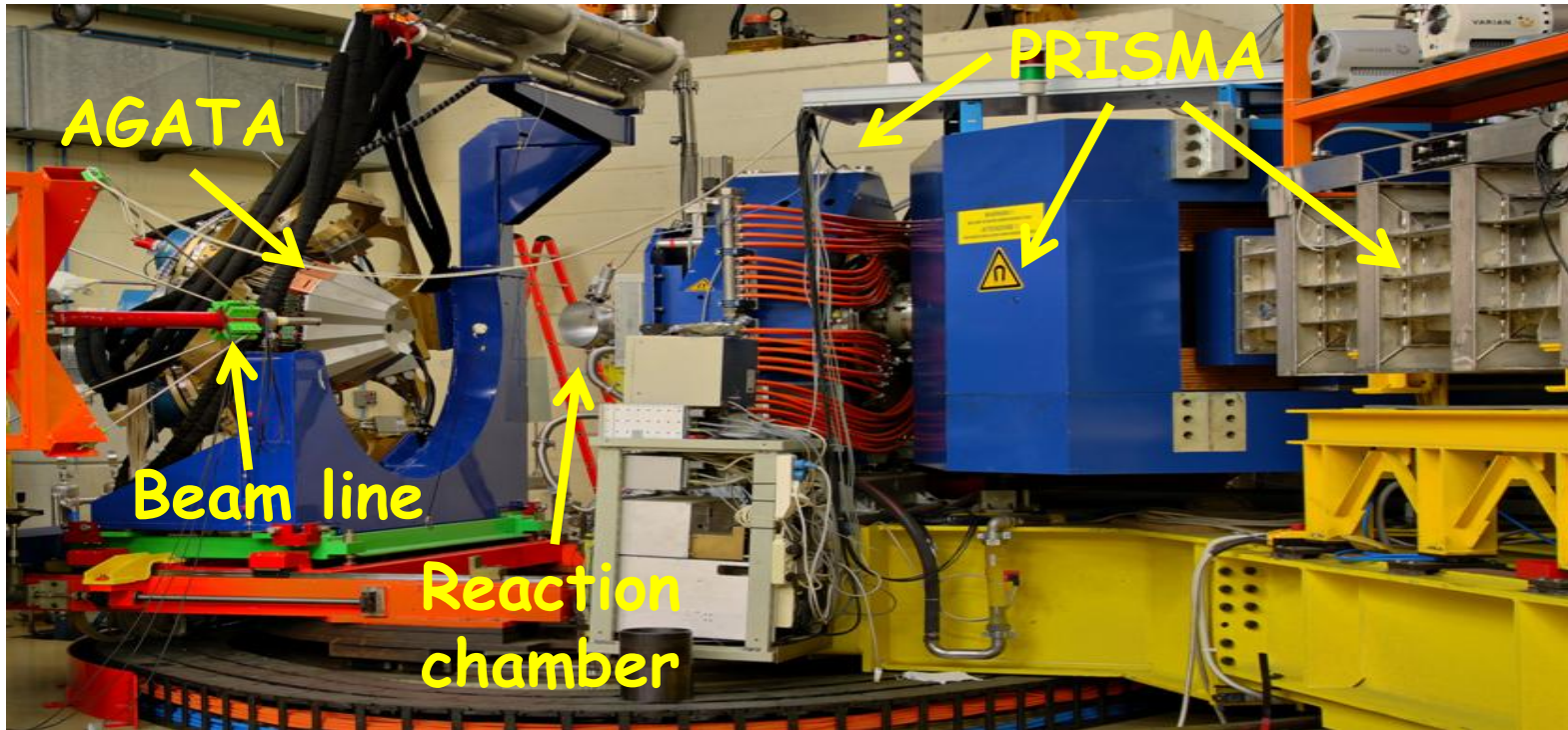

AGATA: Structure of Electronics and DAQ

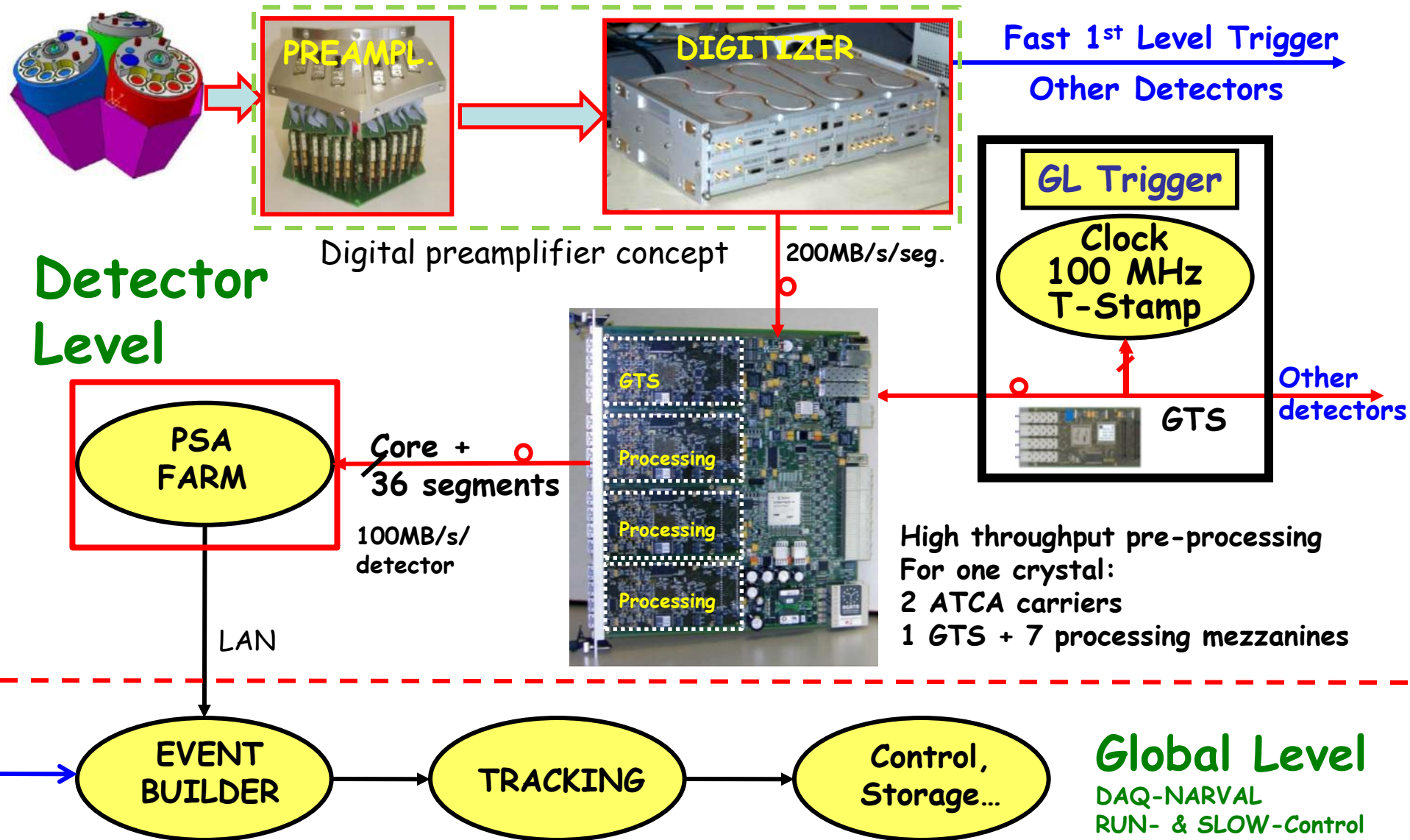

Other detectors:

interface to GTS, merge time-stamped data into event builder, prompt local trigger from digitisers

6 crystals in one ATCA crate

(228 high resolution channels)

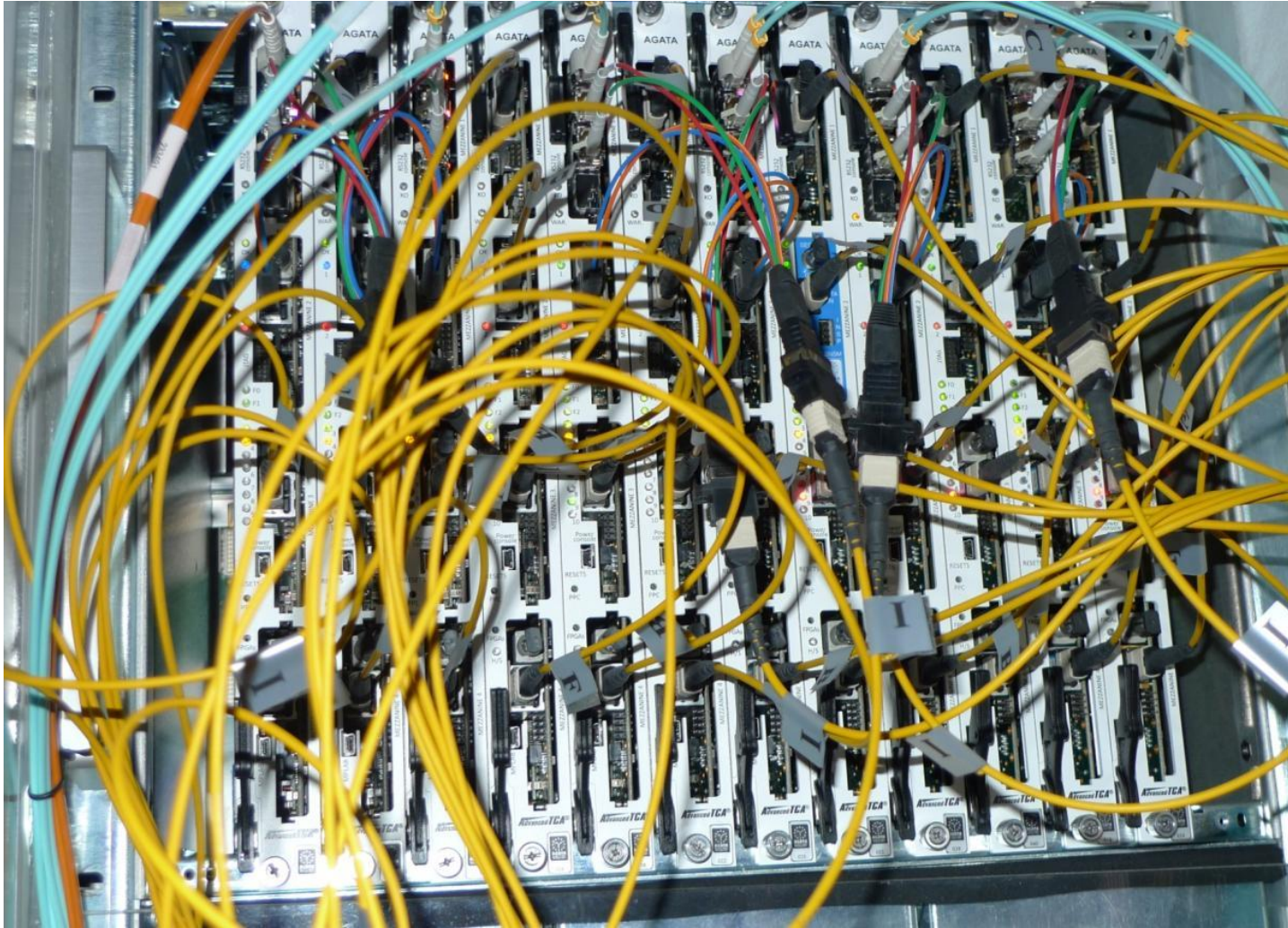

GTS : the system coordinator

All detectors operated on the same 100 MHz clock

Downwards

100 MHz clock + 48 bit Timestamp (updated every 16 clock cycles)

Upwards

trigger requests, consisting of address (8 bit) and timestamp (16 bit)

max request rate 10 MHz total, 1 MHz/detector

Downwards

validations/rejections, consisting of request + event number (24 bit)

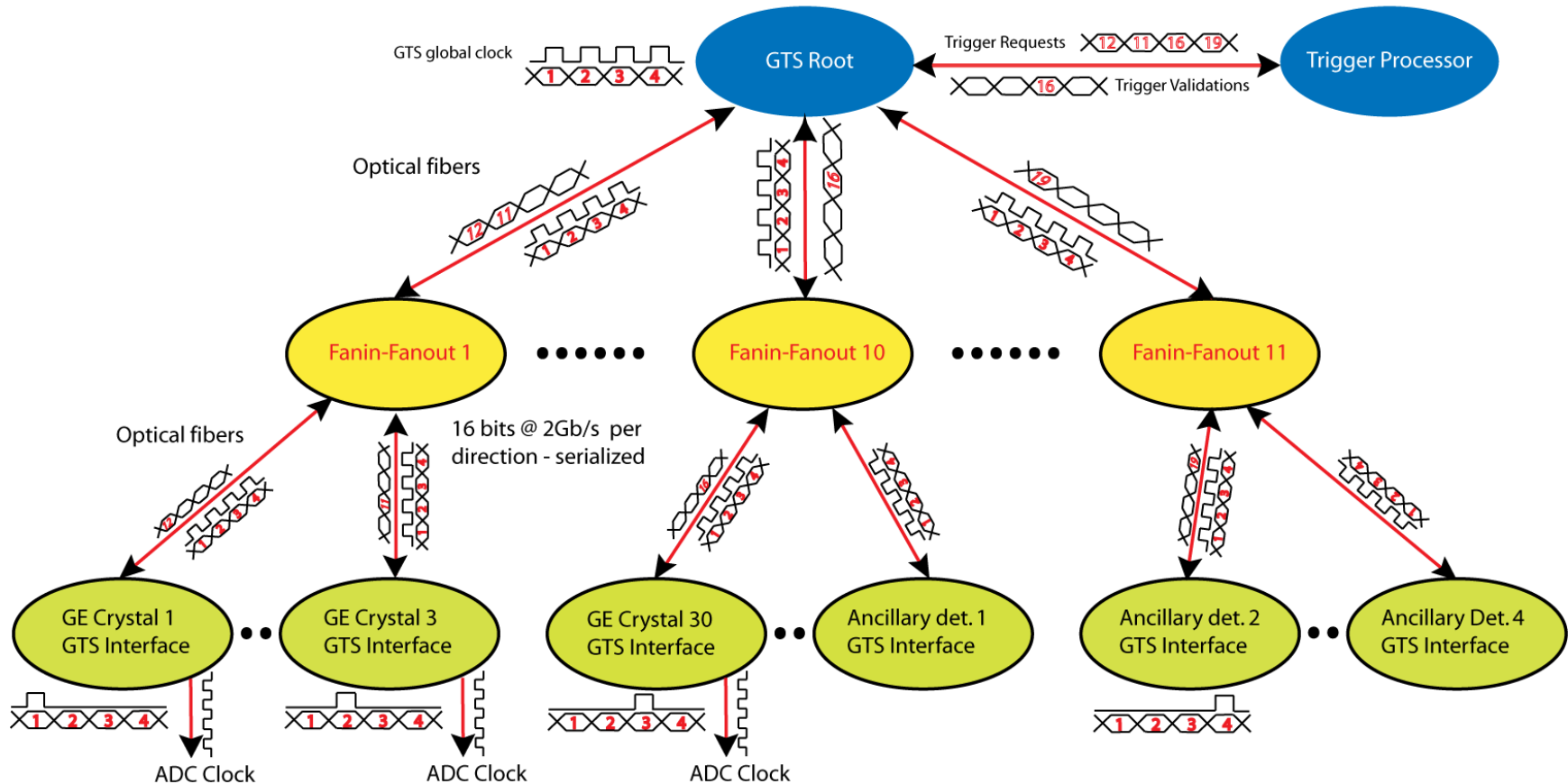

Some important issues

- Cross talk among the channels of one crystal
- Need to run at very high counting rates
- Neutron damage and energy resolution degradation of the segments
 - PSA can be used to restore resolution, so that
 - Annealing of crystals can be done less frequently

Crosstalk

- Crosstalk is present in any segmented detector
- Creates strong energy shifts proportional to fold
- Tracking needs segment energies !

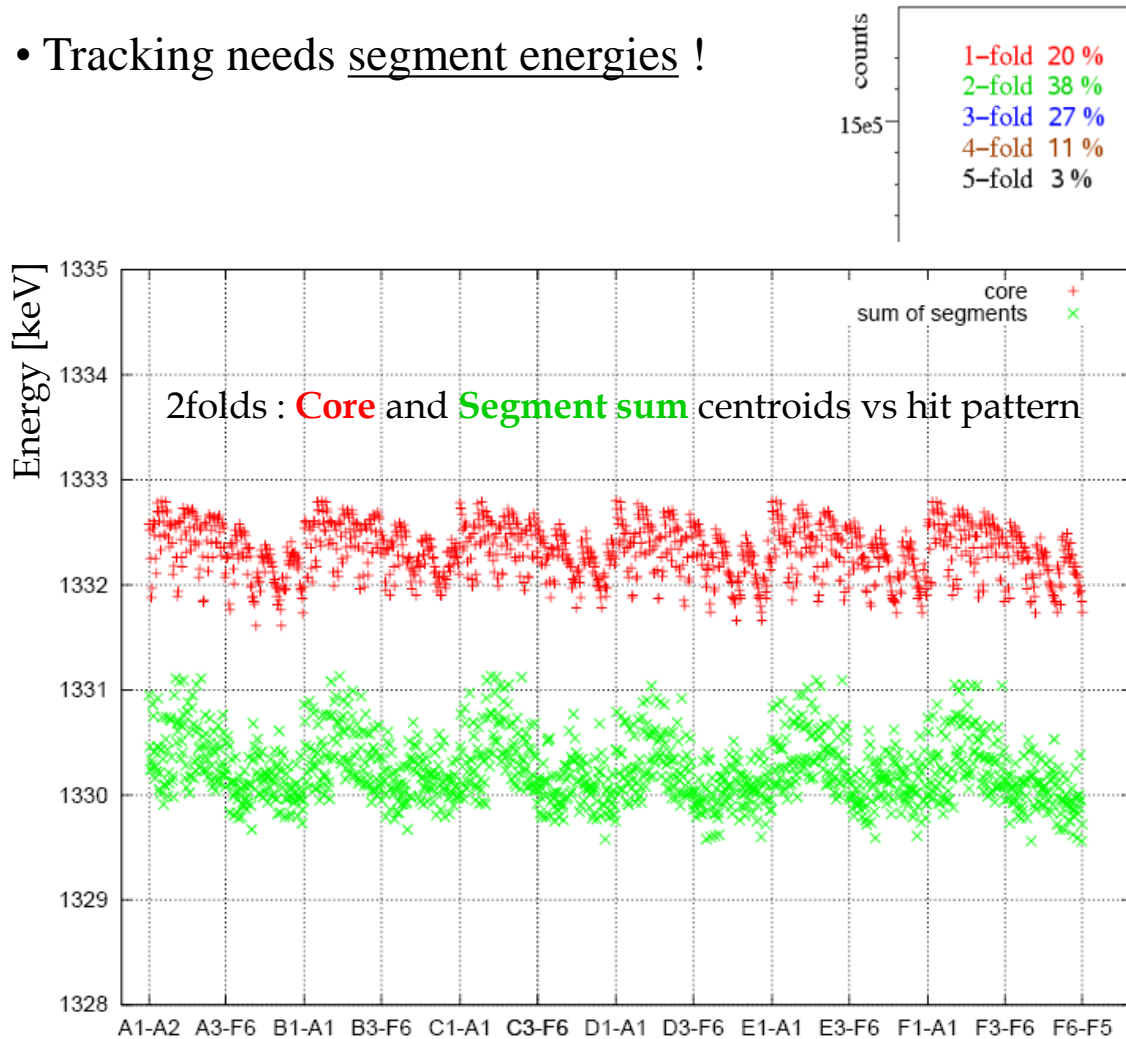

...All possible 2-fold combinations

Sum of segment-energy vs number of hit segments

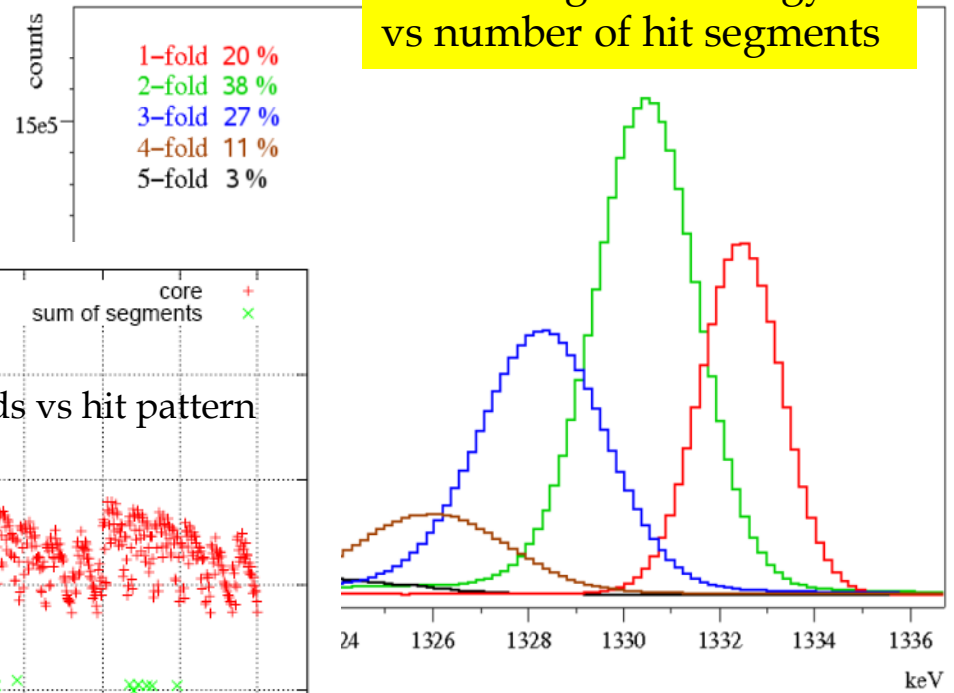

Cross talk correction: Results

FWHM 60keV: 1.20 → 1.02 !

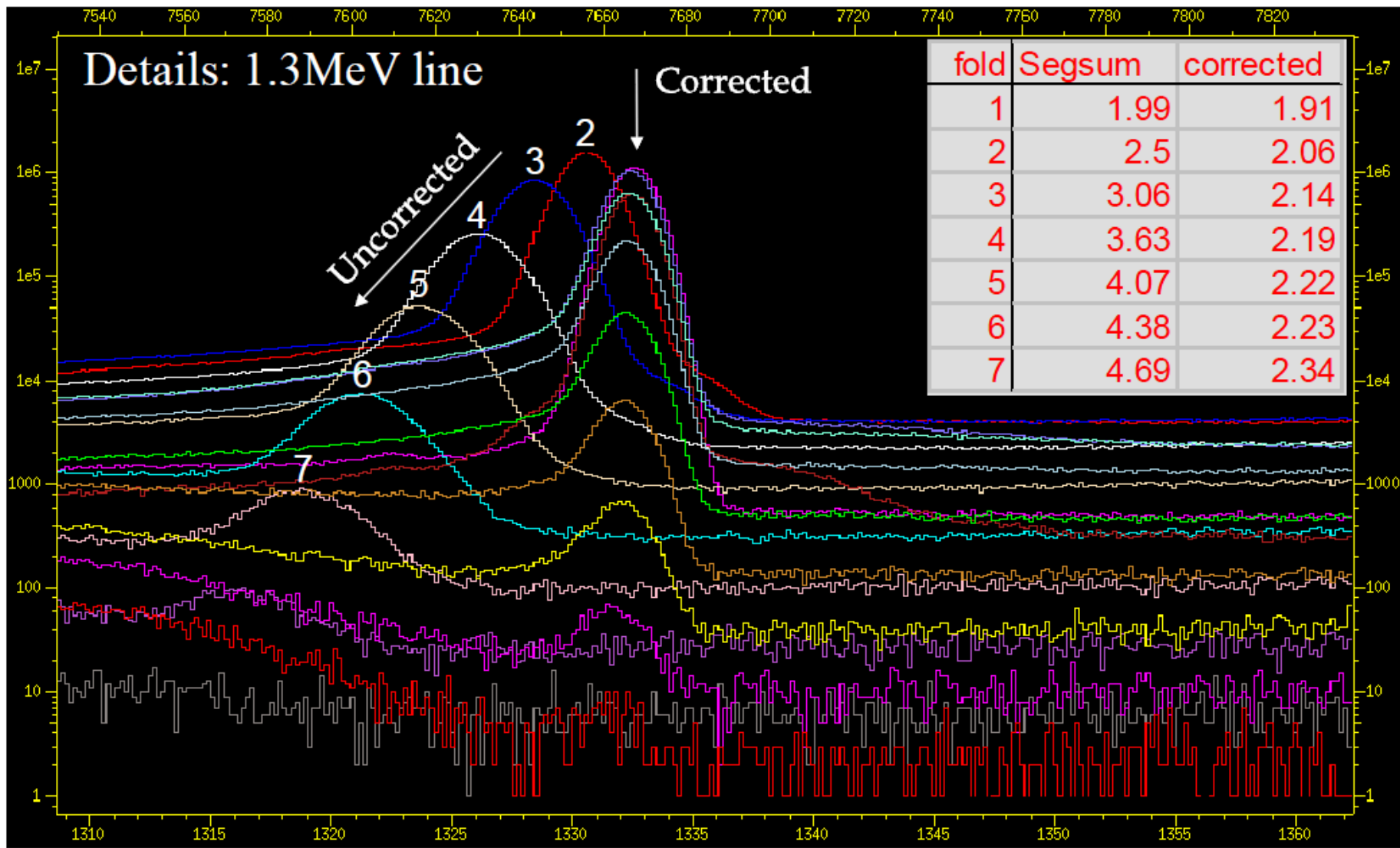

High Count Rate Performance

- The detection efficiency of AGATA is, so far, provided by a small number of crystals.
- Experiments want to collect big statistics → need to run at high singles rates (> 50 kHz).
- Digital Signal Processing allows to work at rates “impossible” with analogue electronics.
- Under these “extreme” conditions, the performance of the detectors is still acceptable.

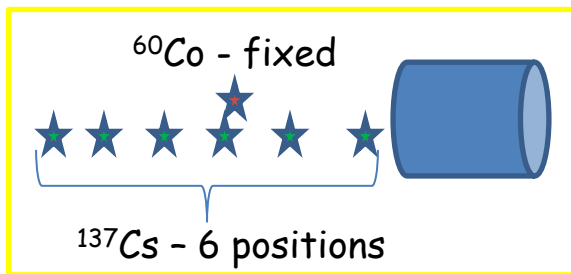

Two Sources Method

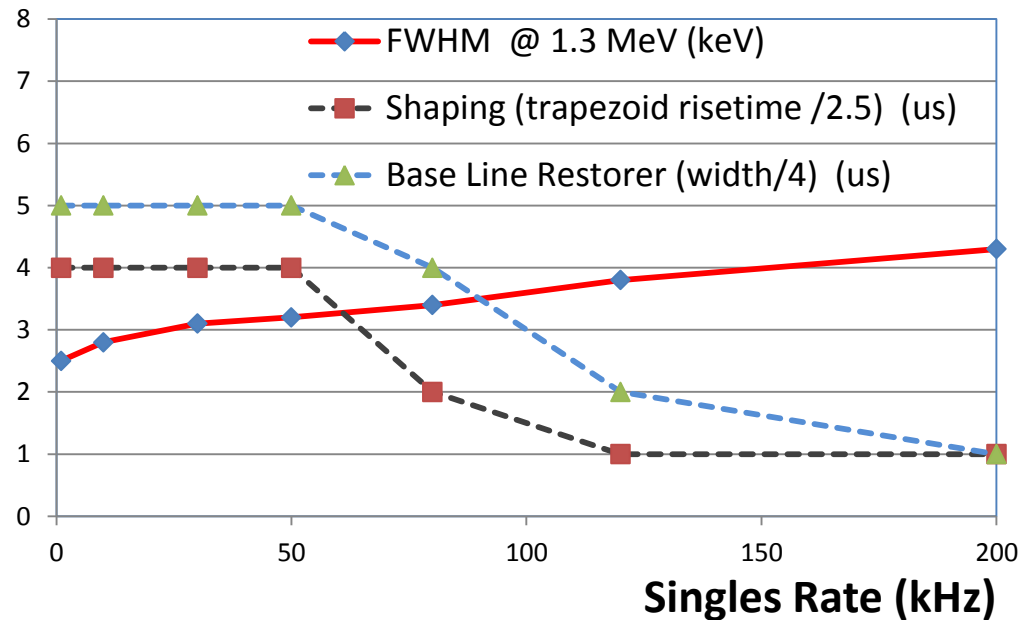

- A limit exists, due to pileup of the signals which exhausts the dynamical range of the FADC. Can counteract this by reducing the gain of the preamplifiers, but then energy resolution is a bit worse also at low counting rate.
- However, running at high singles rates has consequences ...

Neutron damage: shape of the 1332 keV line

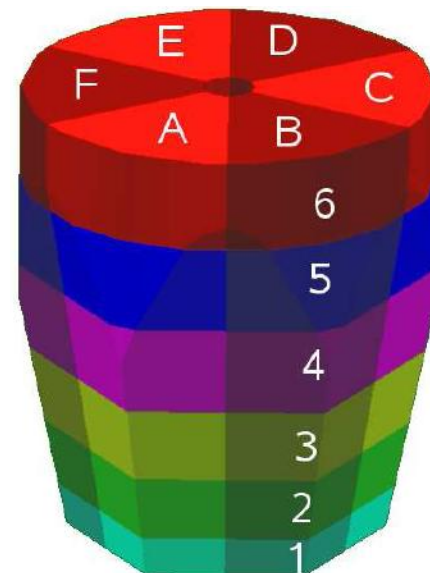
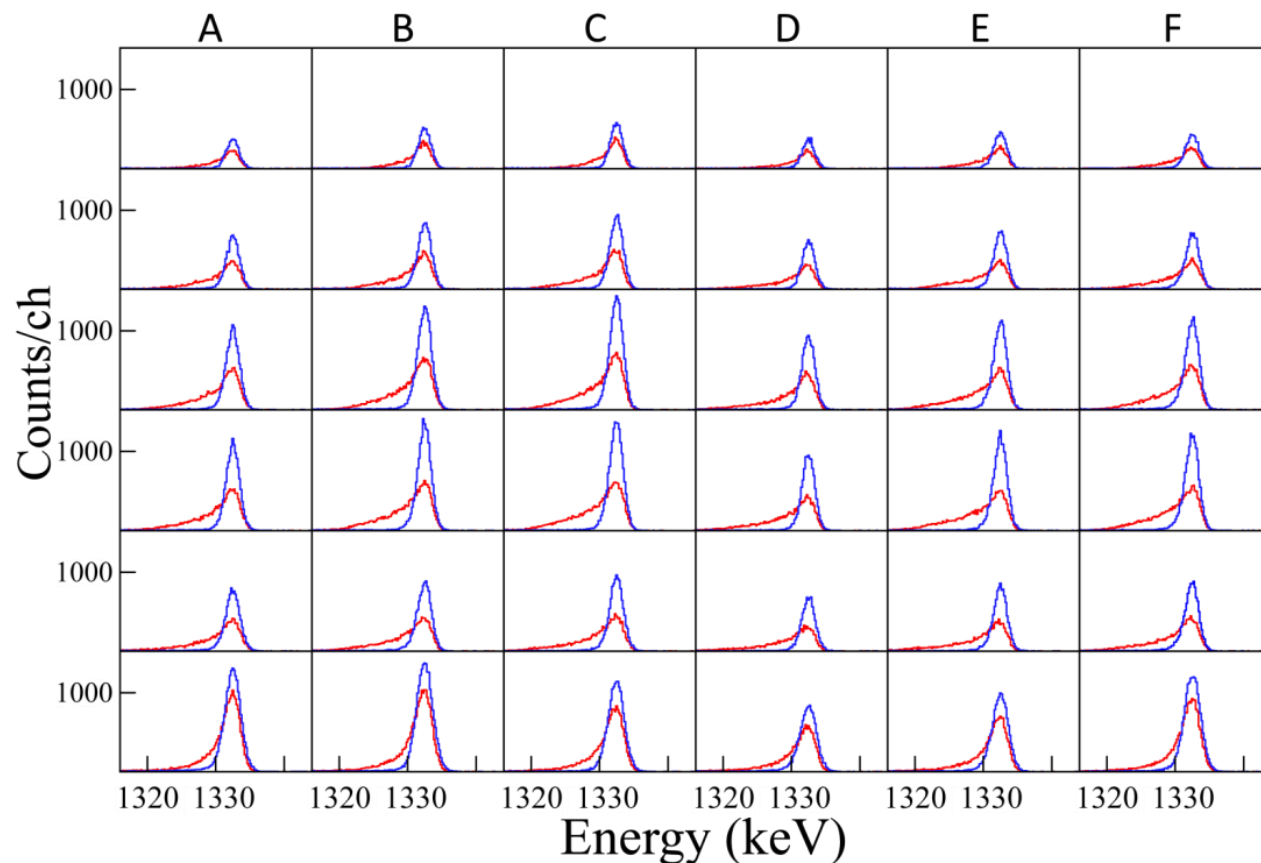

Blue: April 2010 → FWHM(core) ~ 2.3 keV FWHM(segments) ~ 2.0 keV

Red: July 2010 → FWHM(core) ~ 2.4 keV FWHM(segments) ~ 3 keV

Damage after 3 high counting-rate experiments (3 weeks of beam at 30-80 kHz singles)
(and a little help by EXOTIC... 😊)

Worsening seen in most of the detectors; more severe on the forward crystals;
segments are the most affected, cores almost unchanged (as expected for n-type HPGe)

Crystal C002

April 2010

July 2010

→ corrected

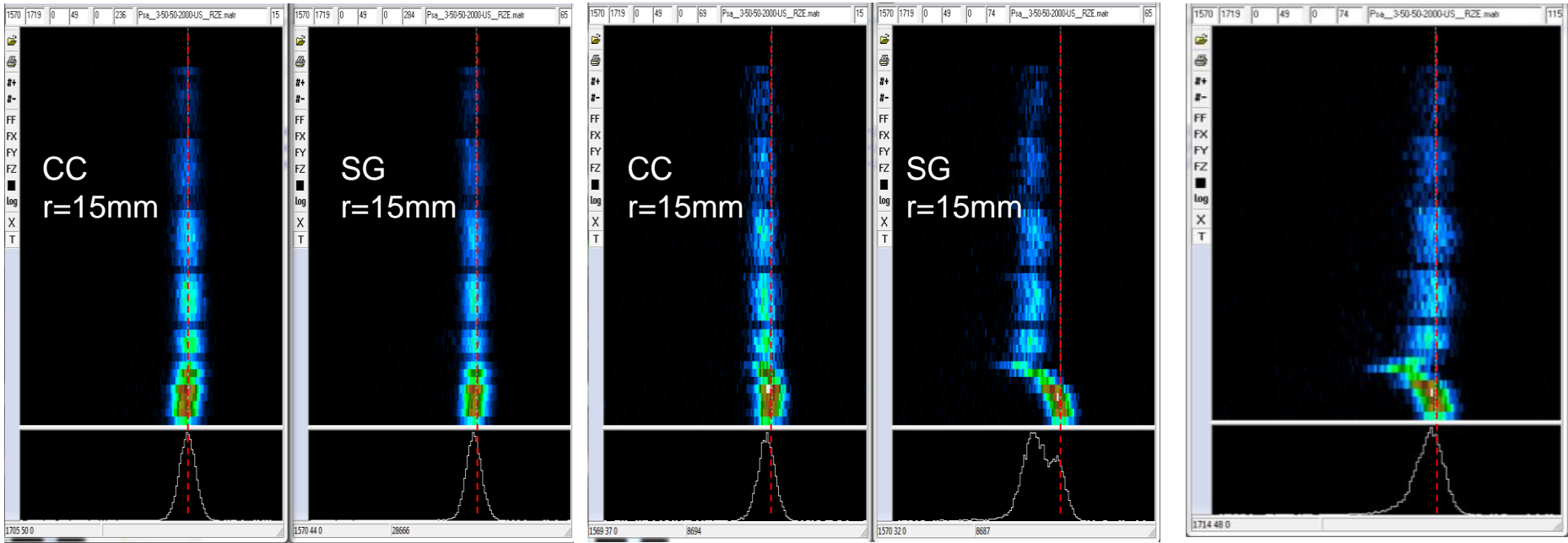

The 1332 keV peak as a function of crystal depth (z) for interactions at $r = 15$ mm

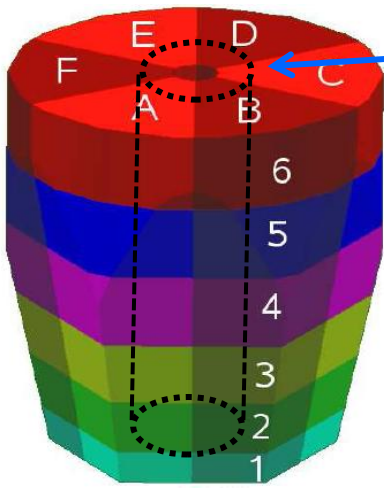

The charge loss due to neutron damage is proportional to the path length to the electrodes.

The position is provided by the PSA (which is barely affected by the amplitude loss).

Knowing the collection path, the charge trapping can be modeled and corrected away (Bart Bruyneel, IKP Köln)

Energy resolution at the end of the LNL campaign

Before and After charge-trapping correction

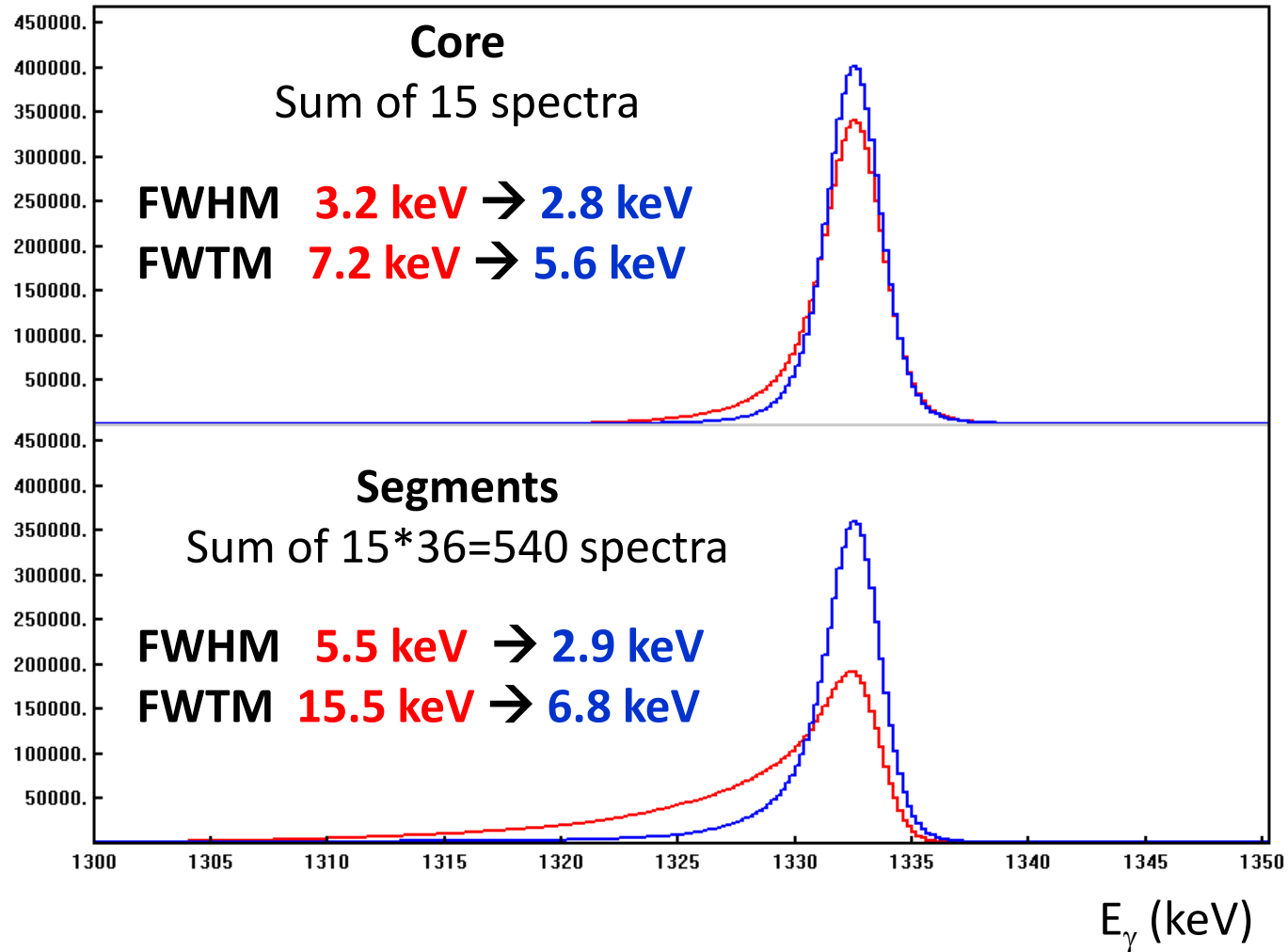

Undamaged detectors: FWHM \sim 2.5 keV, FWTM \sim 4.8 keV

Performance of the Demonstrator

Just a few examples

Doppler Correction Capability, "small" v/c

220 MeV $^{56}\text{Fe} \rightarrow ^{197}\text{Au}$ (ATC1 + DANTE, July 2009)

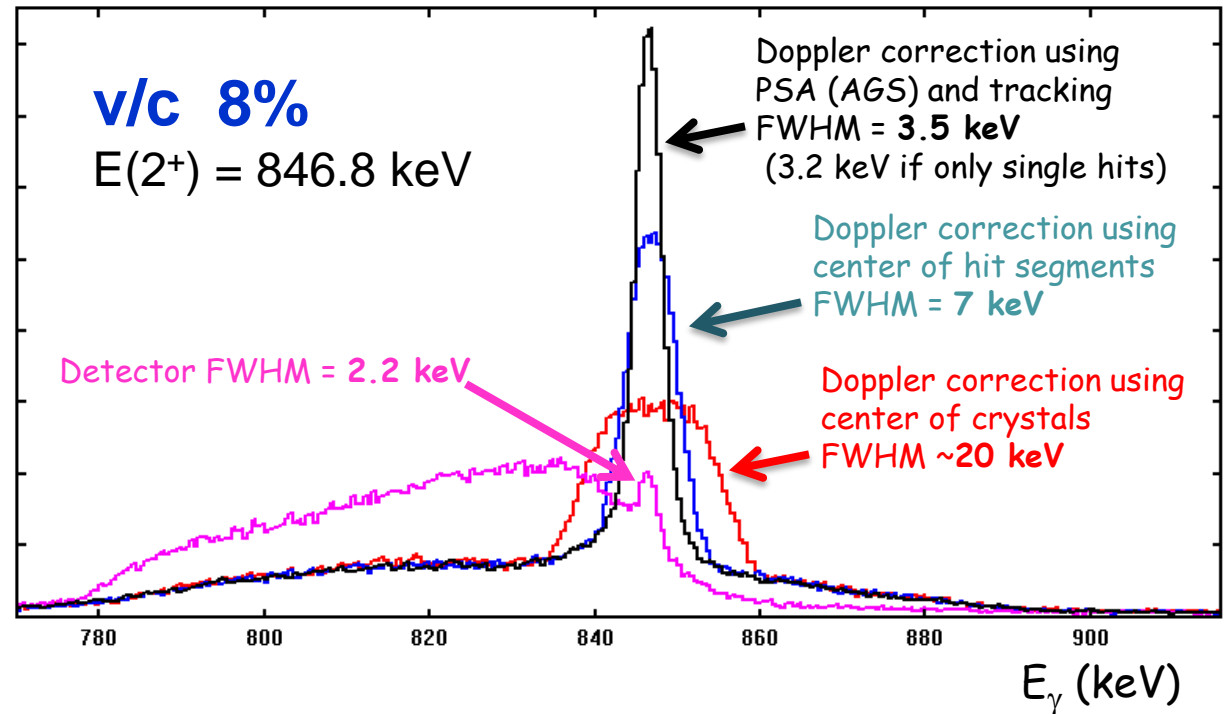
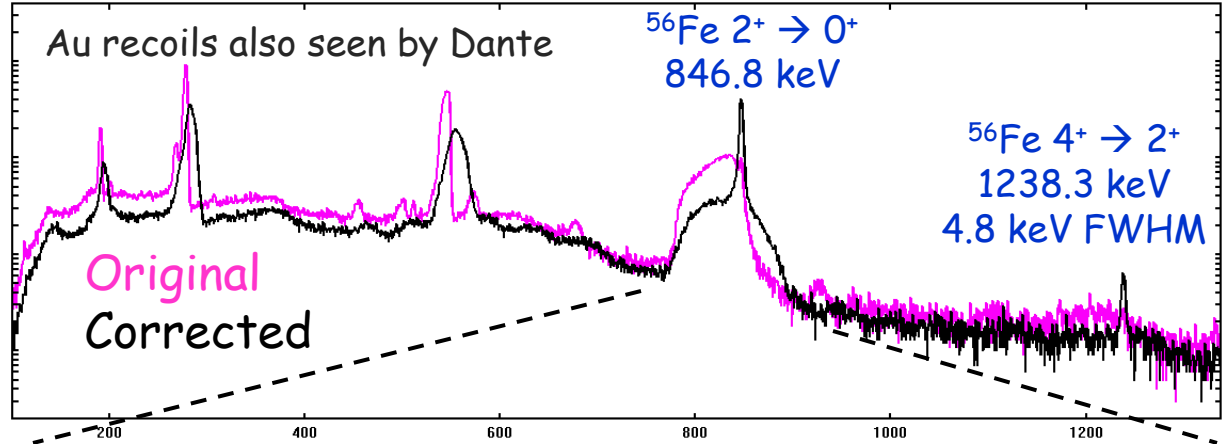
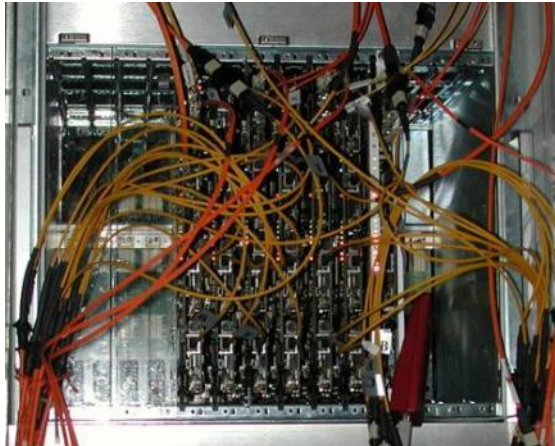
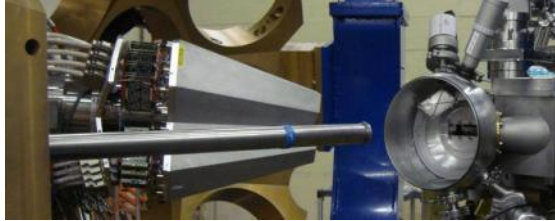

Doppler Correction Capability, "large" v/c

inelastic scattering ^{17}O @ 20 MeV/u on ^{208}Pb

Recoils detected in TRACE

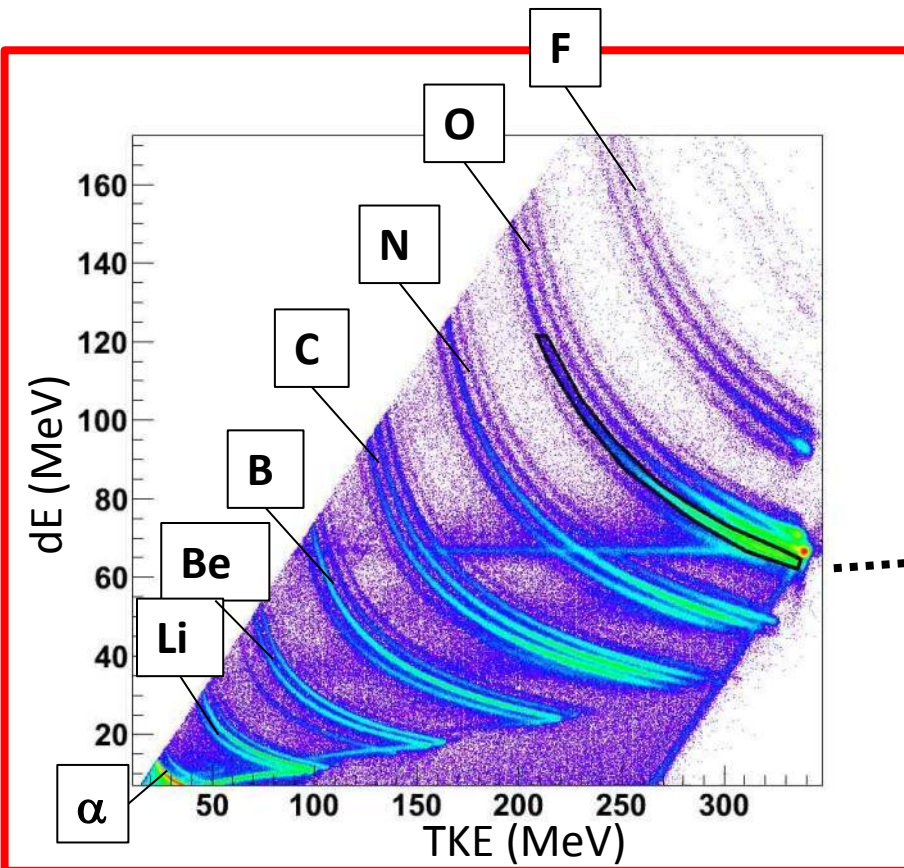

F. Crespi, Milano

^{16}O

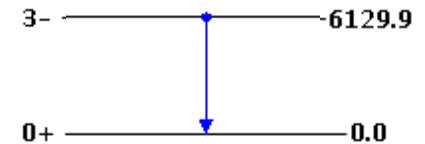

No Doppler Corr.

Crystal Centers

Segment Centers

PSA+Tracking

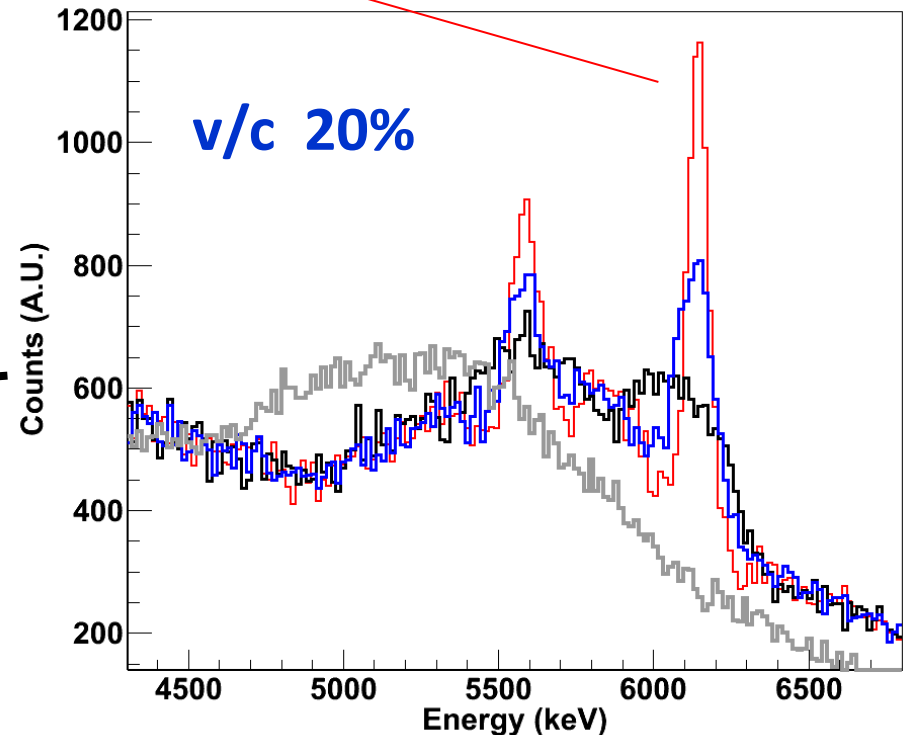

$\gamma\gamma$ capabilities

135 MeV $^{32}\text{S} \rightarrow ^{110}\text{Pd}$ (6 AGATA crystals)

The performance of AGATA using γ -ray tracking is comparable to conventional arrays with a much larger number of crystals

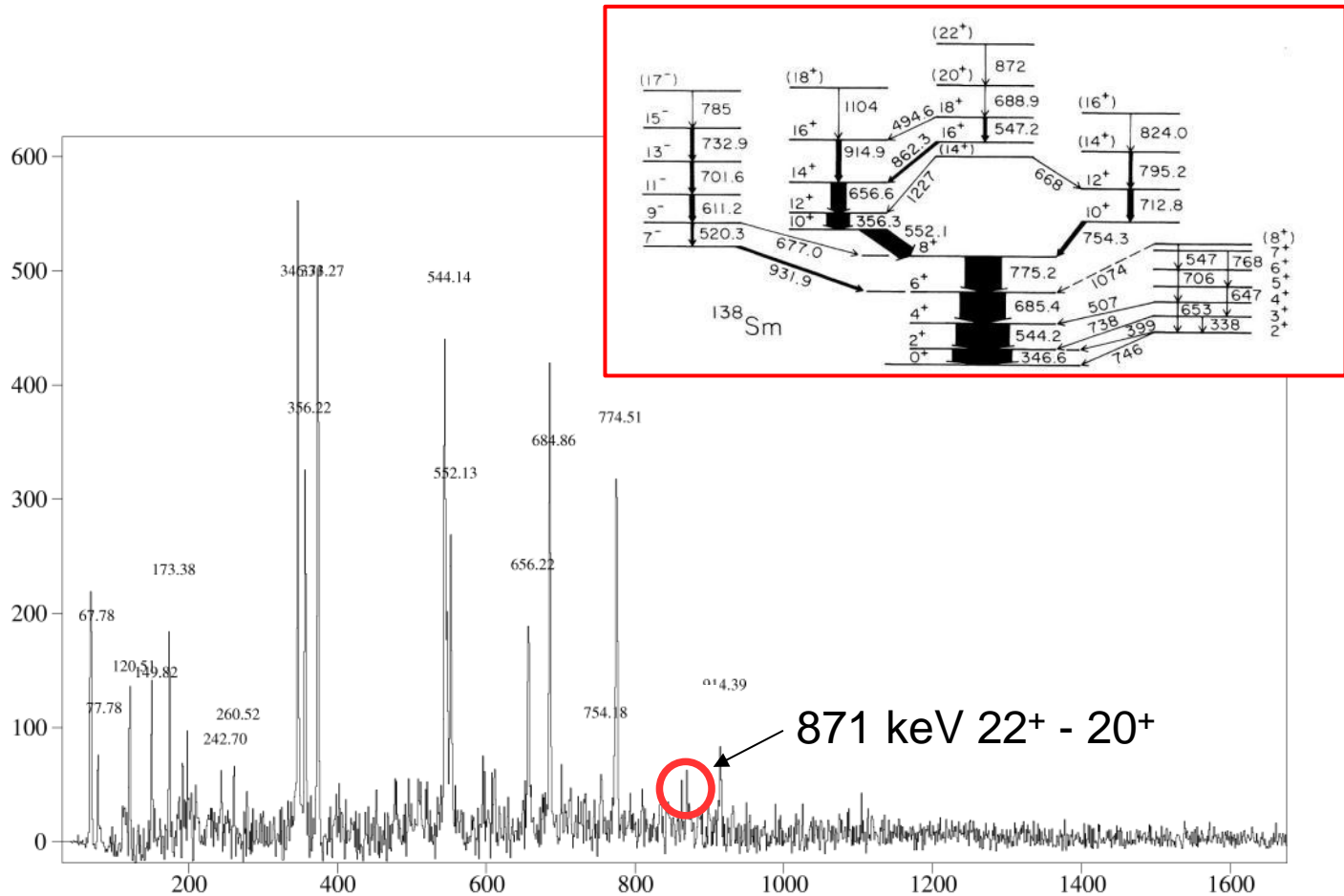
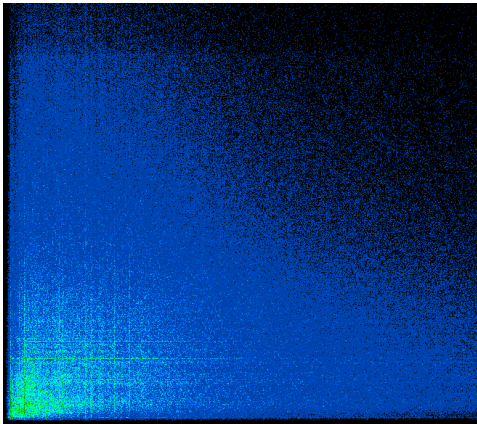

^{138}Sm
 6 gates on:
 347keV, 545keV, 686
 keV, 775keV, 552keV,
 357keV

Imaging of $E_\gamma = 1332$ keV gamma rays

AGATA used as a big Compton Camera

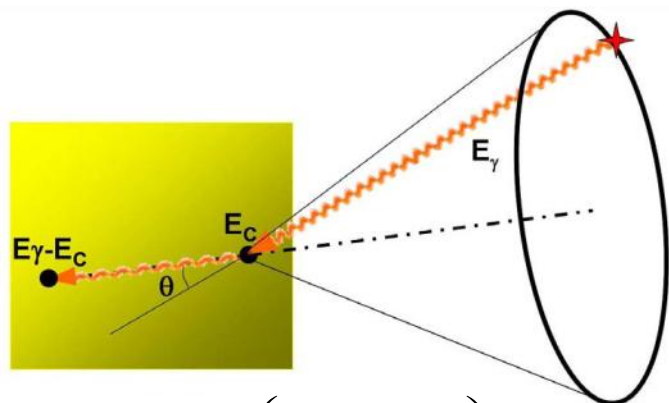

$$\cos \theta = 1 + \left(\frac{1}{E_\gamma} - \frac{1}{E'_\gamma} \right) m_0 c^2$$

Far Field Backprojection

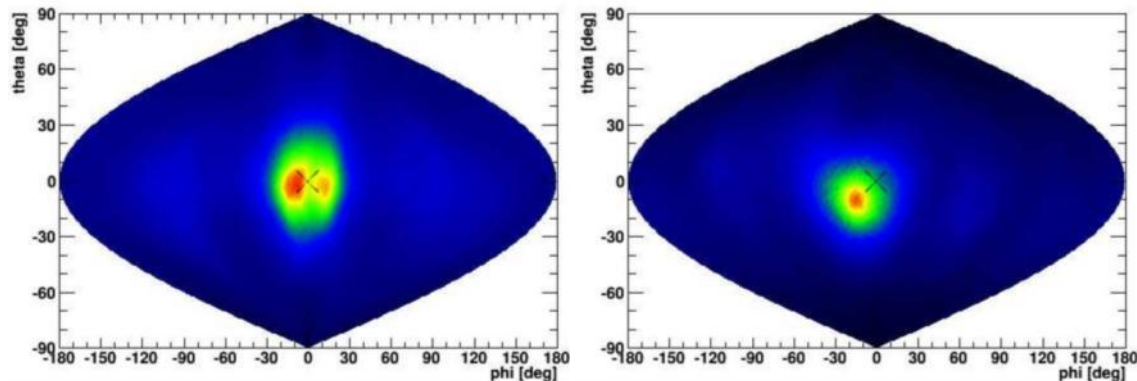

All 9 detectors

One detector

Near Field Backprojection

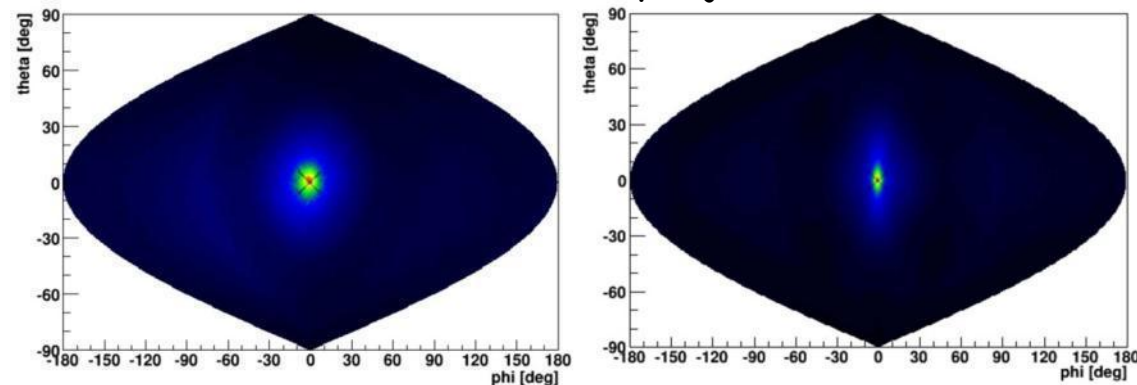

All 9 detectors

One detector

Source at 51 cm \rightarrow $\Delta x \sim \Delta y \sim 2$ mm $\Delta z \sim 2$ cm

F. Recchia, Padova

The Experimental Campaign at LNL

2010-2011

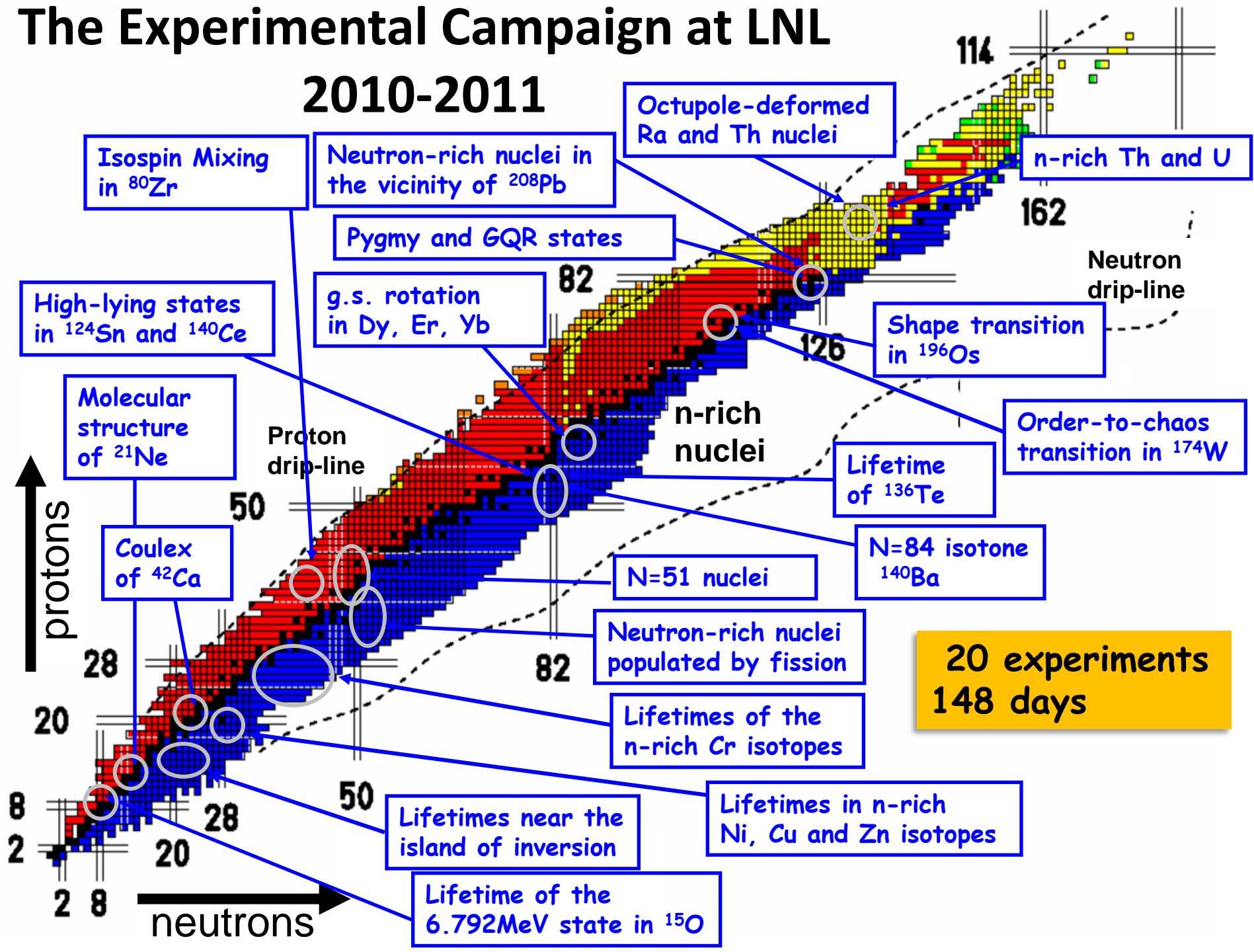

Differential RDDS measurements at LNL

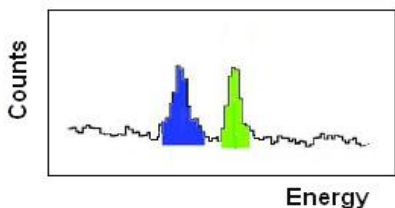
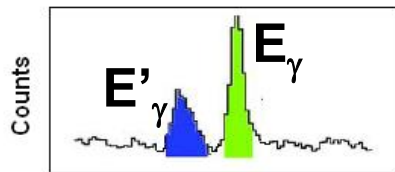
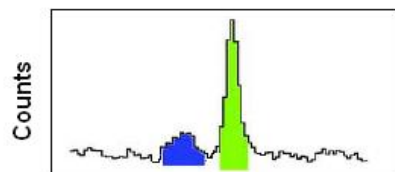
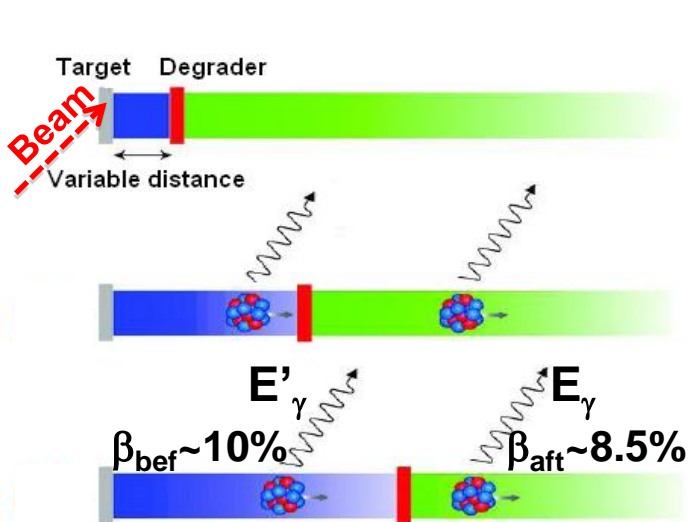

$^{76}\text{Ge} + ^{238}\text{U}$ 577 MeV
 $^{72}\text{Zn}(-2p-2n)$

Spectra at 50 kHz singles rate

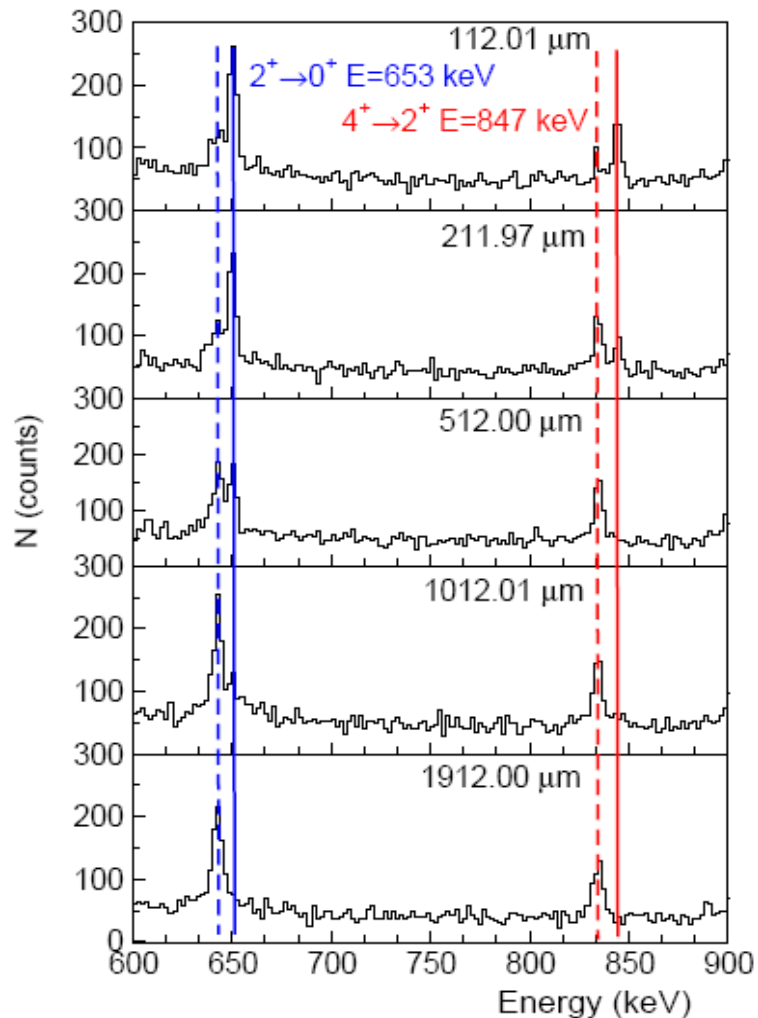

RDDS
 measurement
 $\theta_G = 55^\circ$

IKP University Köln
 TU Darmstadt
 PLUNGER

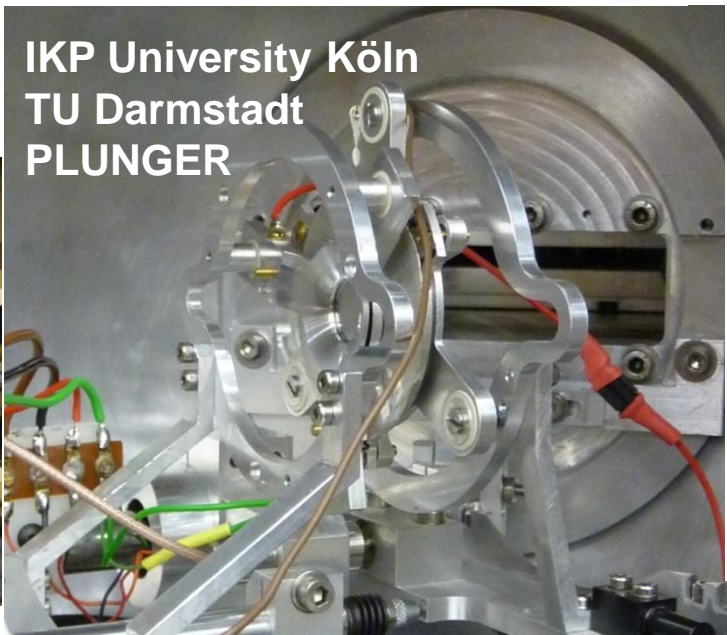

AGATA-PRISMA

Lifetime measurement of the 6.79 MeV state in ^{15}O

$^{14}\text{N}(^2\text{H},n)^{15}\text{O}$ and $^{14}\text{N}(^2\text{H},p)^{15}\text{N}$ reactions @ 32 MeV (XTU LNL Tandem)

Direct lifetime measurement with 4 ATCs at backward angles (close to the beam-line)

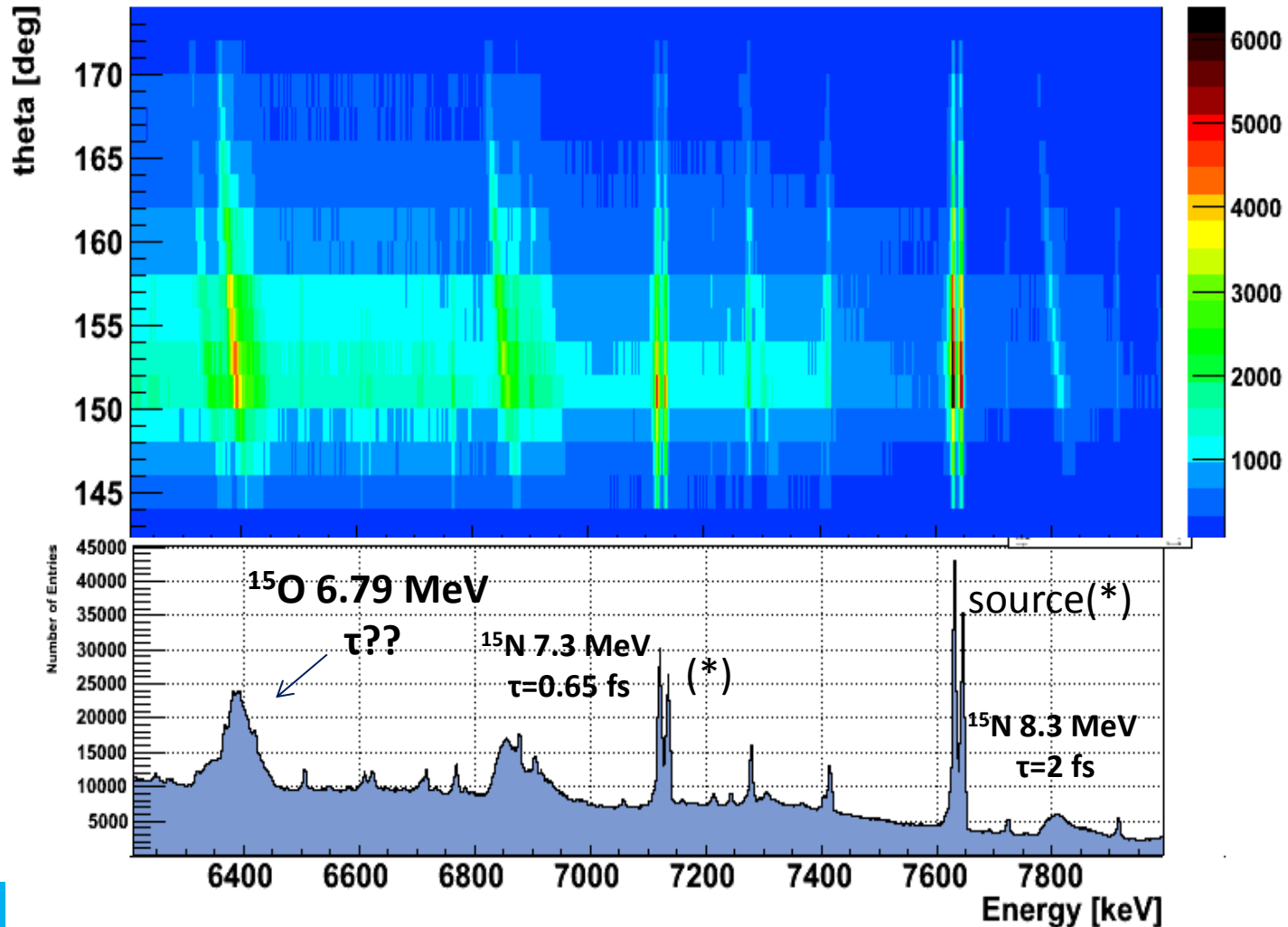
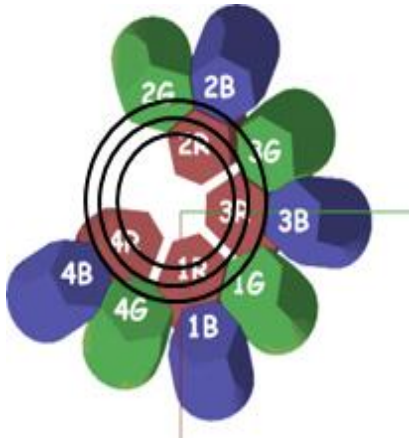

Lifetime measurement of the 6.79 MeV state in ^{15}O

$^{14}\text{N}(^2\text{H},n)^{15}\text{O}$ and $^{14}\text{N}(^2\text{H},p)^{15}\text{N}$ reactions @ 32 MeV (XTU LNL Tandem)

Direct lifetime measurement with 4 ATCs at backward angles (close to the beam-line)

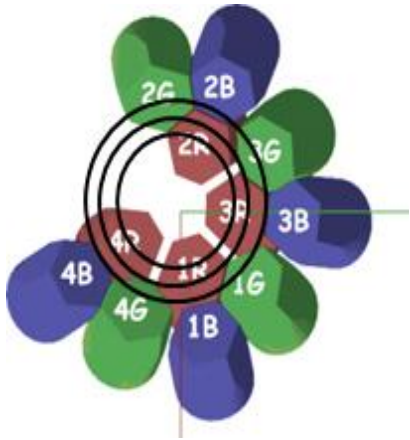

Detected gamma-rays can be sorted in few degrees θ "slices" with a continuous distribution

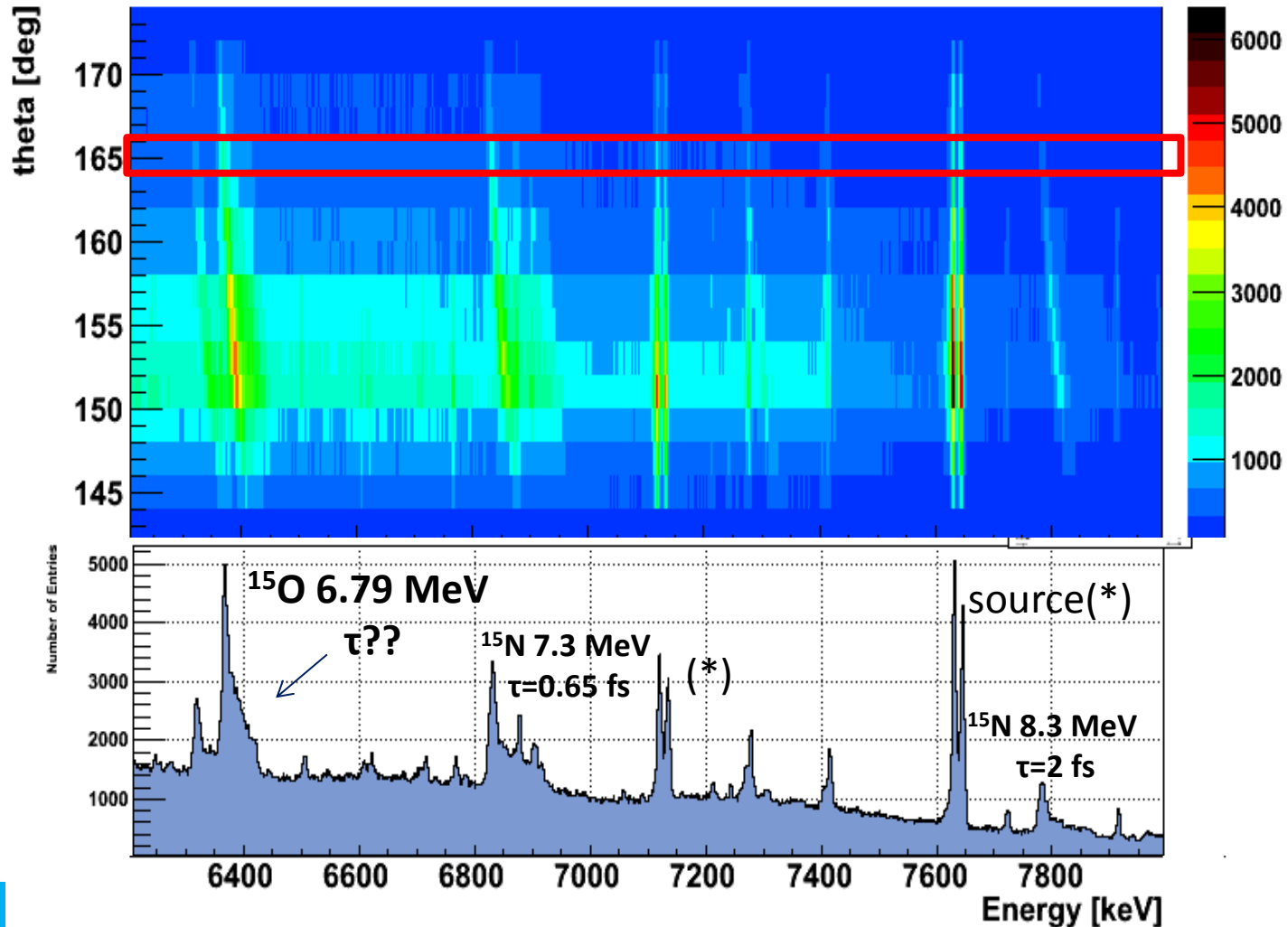

^{15}O

The 6.79 MeV level in ^{15}O

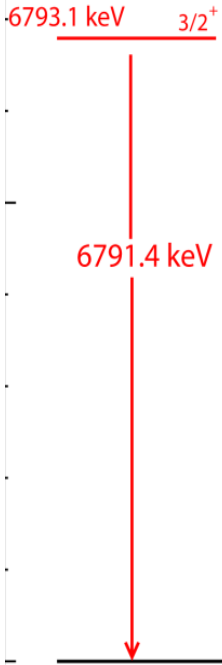

Transfer
+
CN reaction

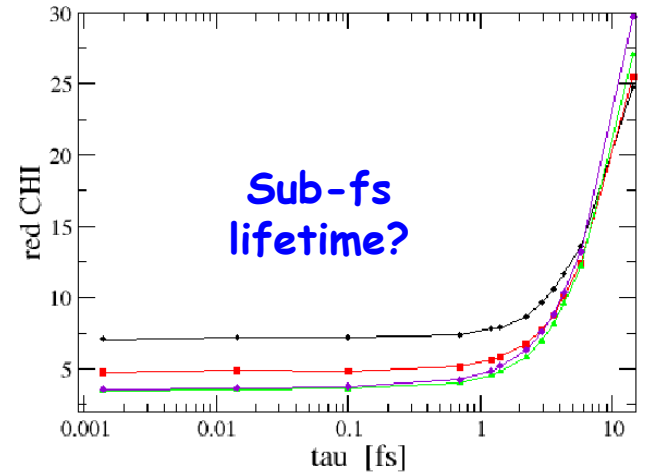
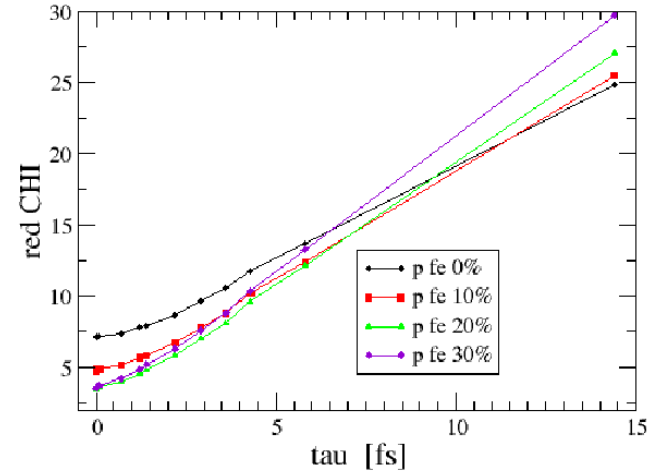
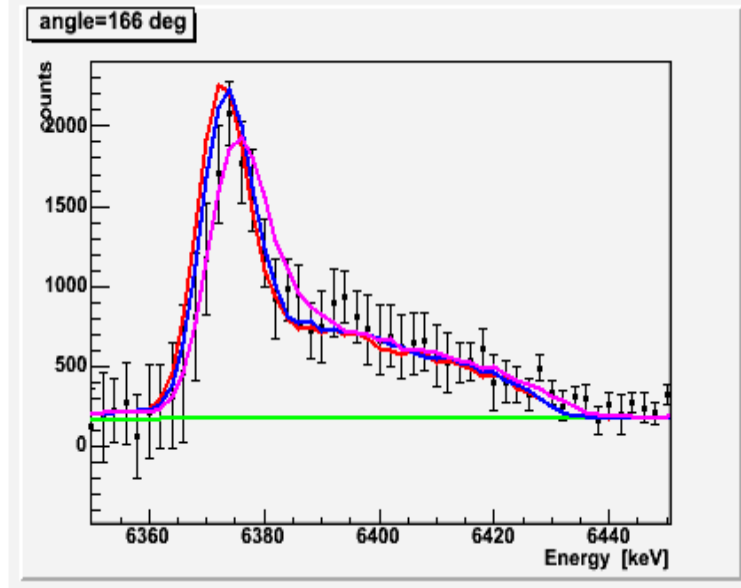
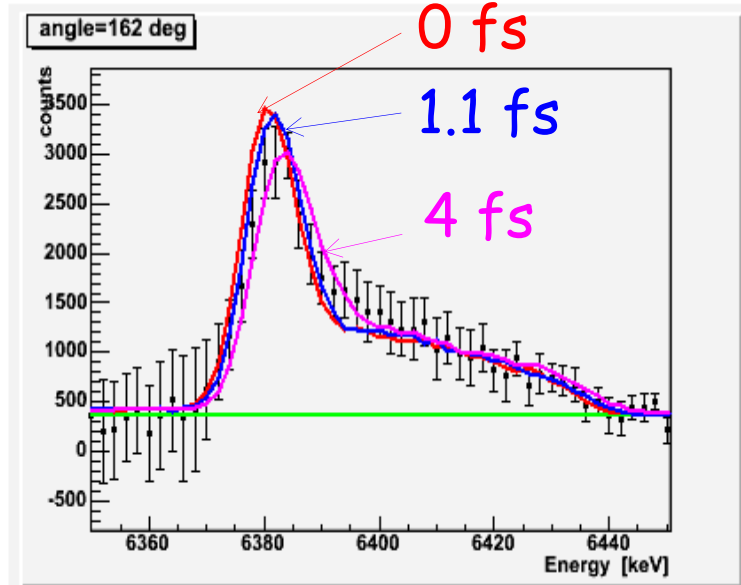
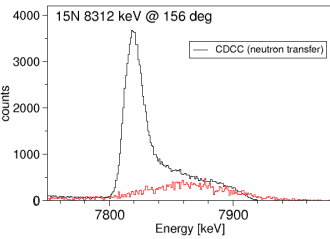

Sensitivity to sub-fs lifetimes due to position resolution of the AGATA crystals

Order-to-chaos in ^{174}W

High-Spin Fusion Evaporation

^{50}Ti on ^{128}Te @ 217 MeV, $I \geq 60\hbar$

Loss of selection rules on K with temperature

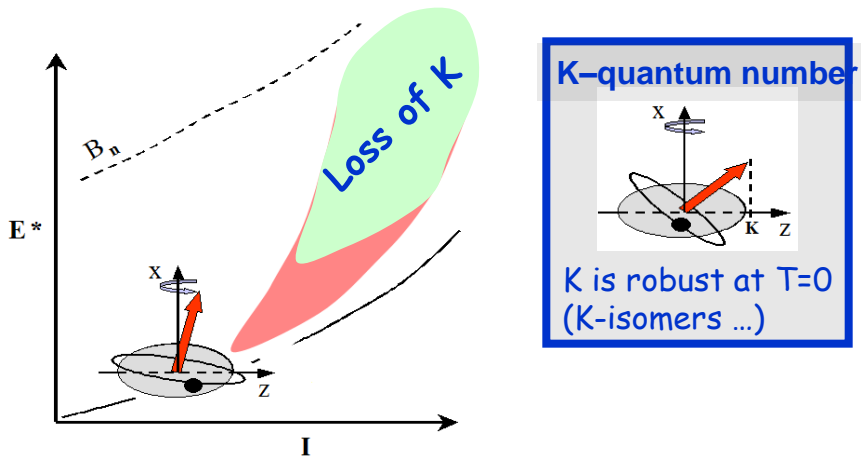

Goal: populate ^{174}W at the **highest possible spins** ($\geq 60\hbar$), in order to make the **statistical fluctuation analysis of the ridge-valley structures in the γ - γ matrices**, to estimate the number of low- K and high- K bands and their correlation

4 Triple Clusters

2 and 3 folds:

$\varepsilon_{2\gamma}=30\%$, $\varepsilon_{3\gamma}=10\%$

($M_\gamma = 30$)

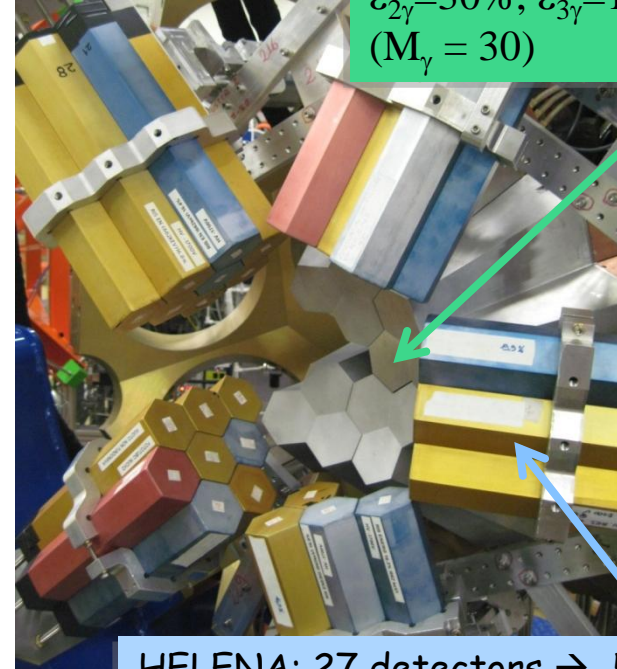

HELENA: 27 detectors \rightarrow 5 clusters of BaF_2 (3" \times 3", exagonal)
Total solid angle: 25% of 4π
Total efficiency: 16% @ 500keV

V. Vandone, S. Leoni, Milano

Helena: selection of high-K bands

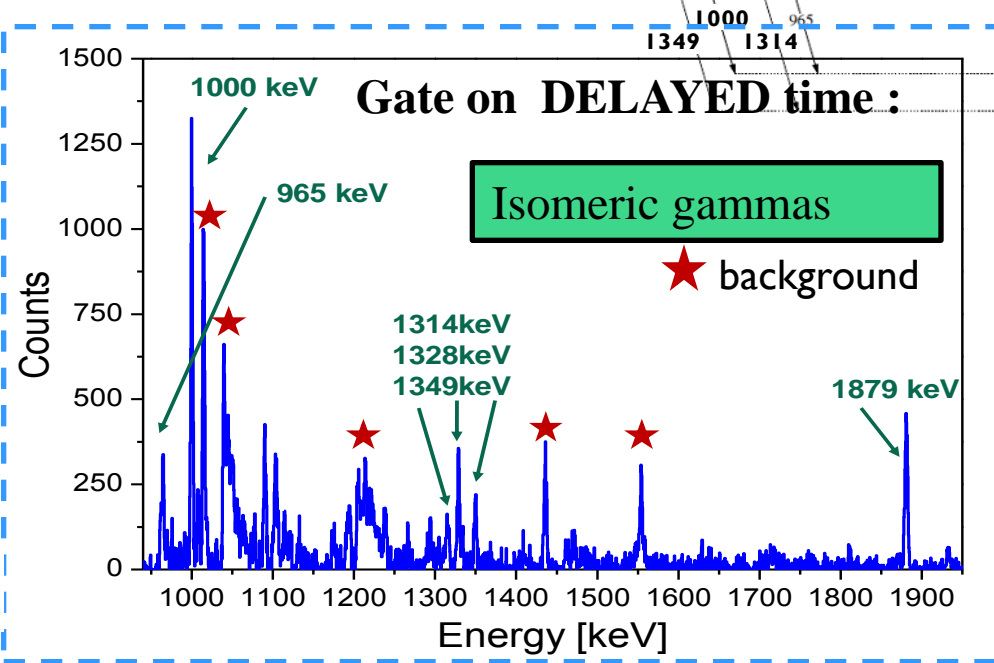
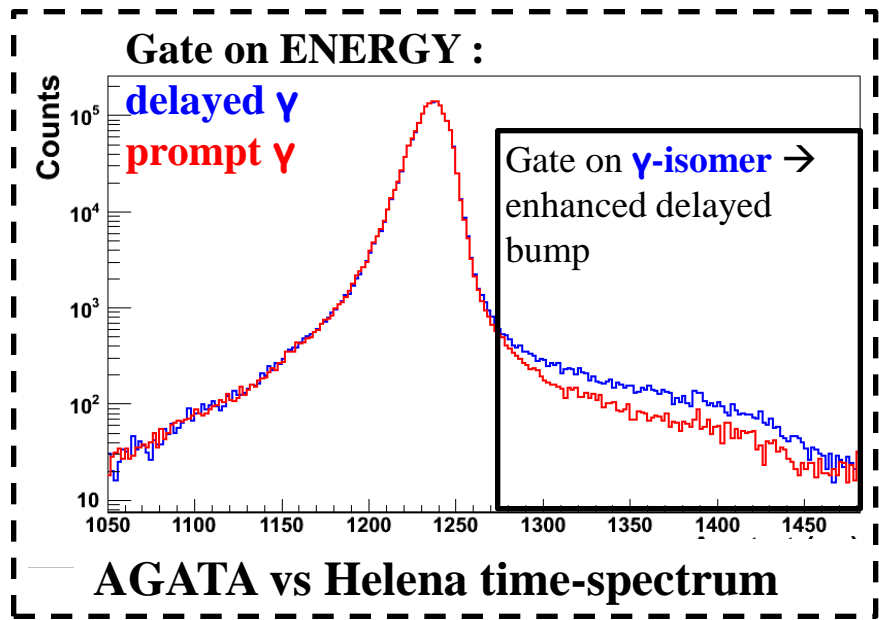
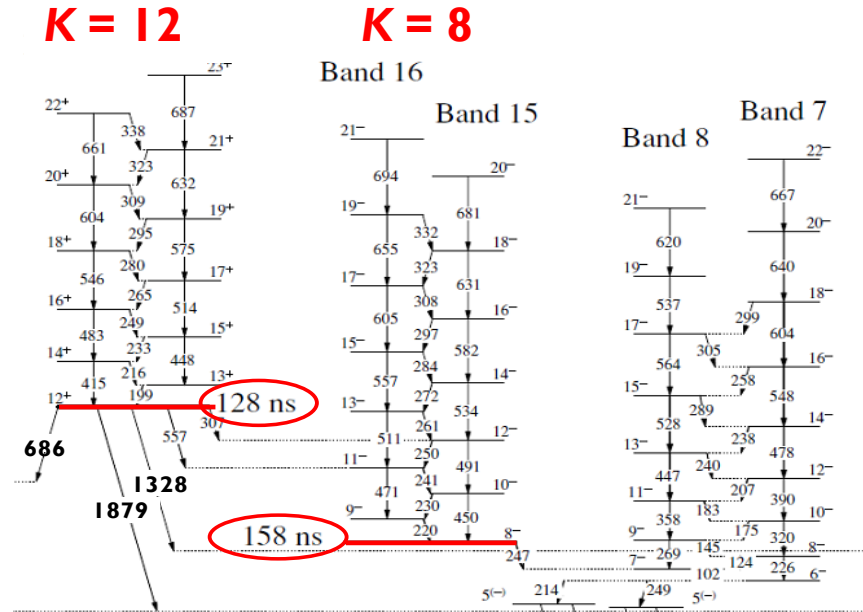
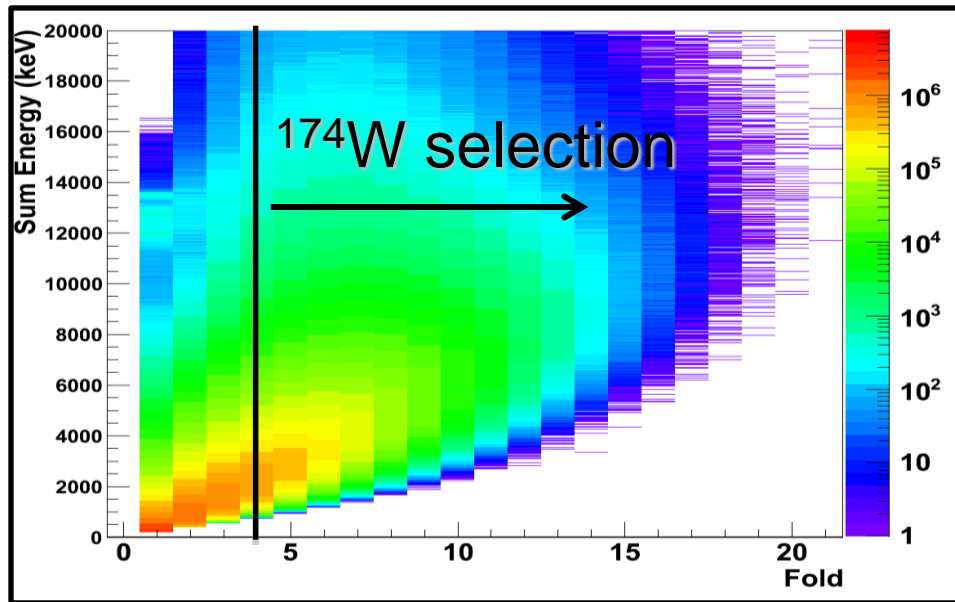

Quasi-Continuum γ - γ matrices

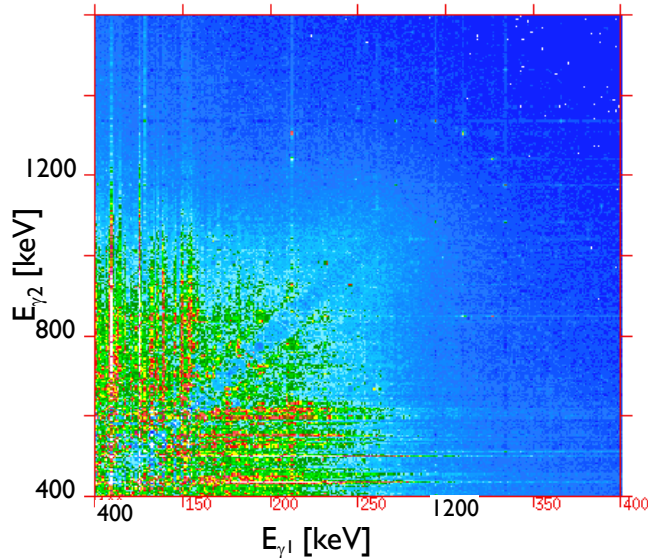

Statistical fluctuation analysis of ridges:
Number of bands below 1 MeV

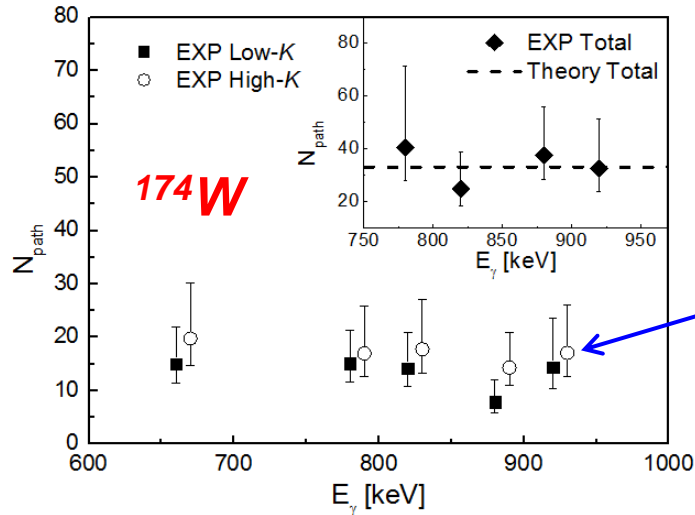

Similar number Low-K and High-K Bands
As in the only studied case of ^{163}Er

Perspectives:

Covariance Analysis between Low-K and High-K spectra \rightarrow

similarity of different cascades, test of the selection rules

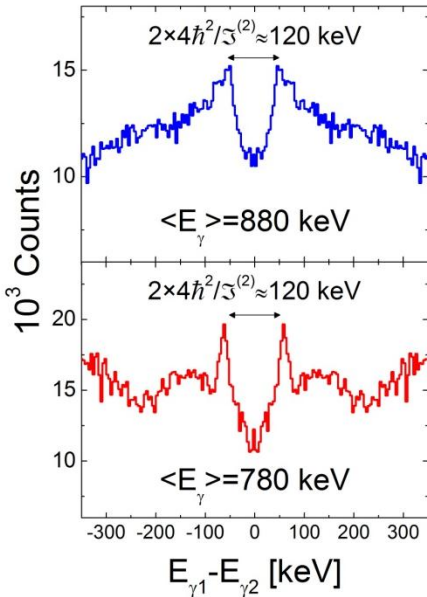

Is the K quantum number conserved up to $E^* < 1 \text{ MeV}$?

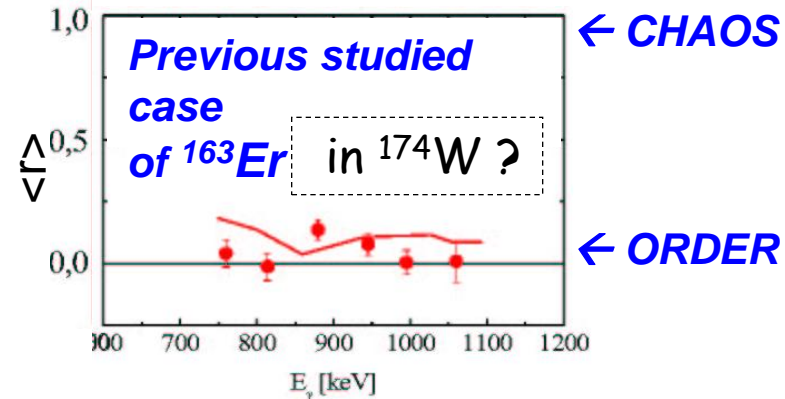

From the Demonstrator to AGATA 1 π

Plans for the next few years

LNL: 2010-2011
15 crystals (5TC)
Total Eff. ~6%



GSI: 2012-2013
25 crystals (5DC+5TC)
Total Eff. ~10%



GANIL: 2014-2015
45 crystals (15 TC)
Total Eff. ~15%

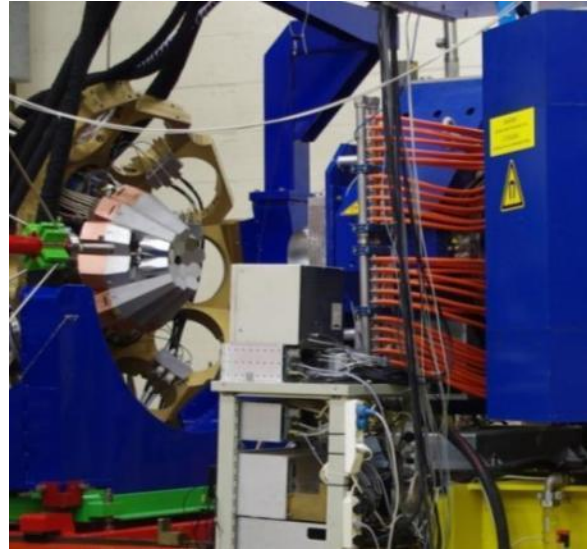

Demonstrator + PRISMA
“backward”

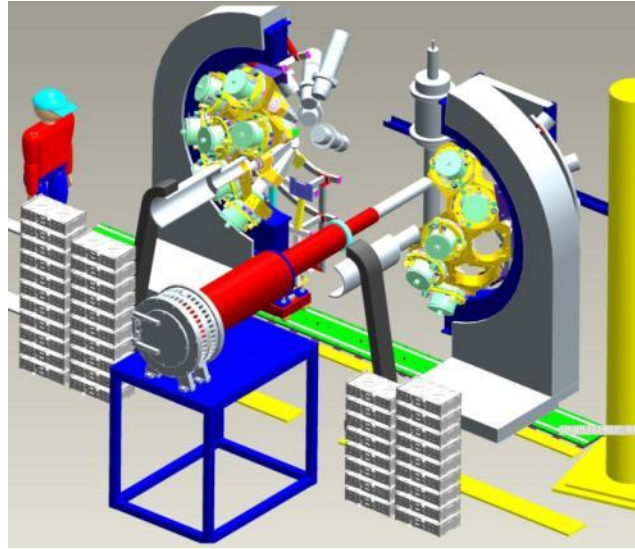

AGATA + FRS
“forward”



AGATA+VAMOS
“backward”

AGATA at the GSI-FRS in-flight RIB

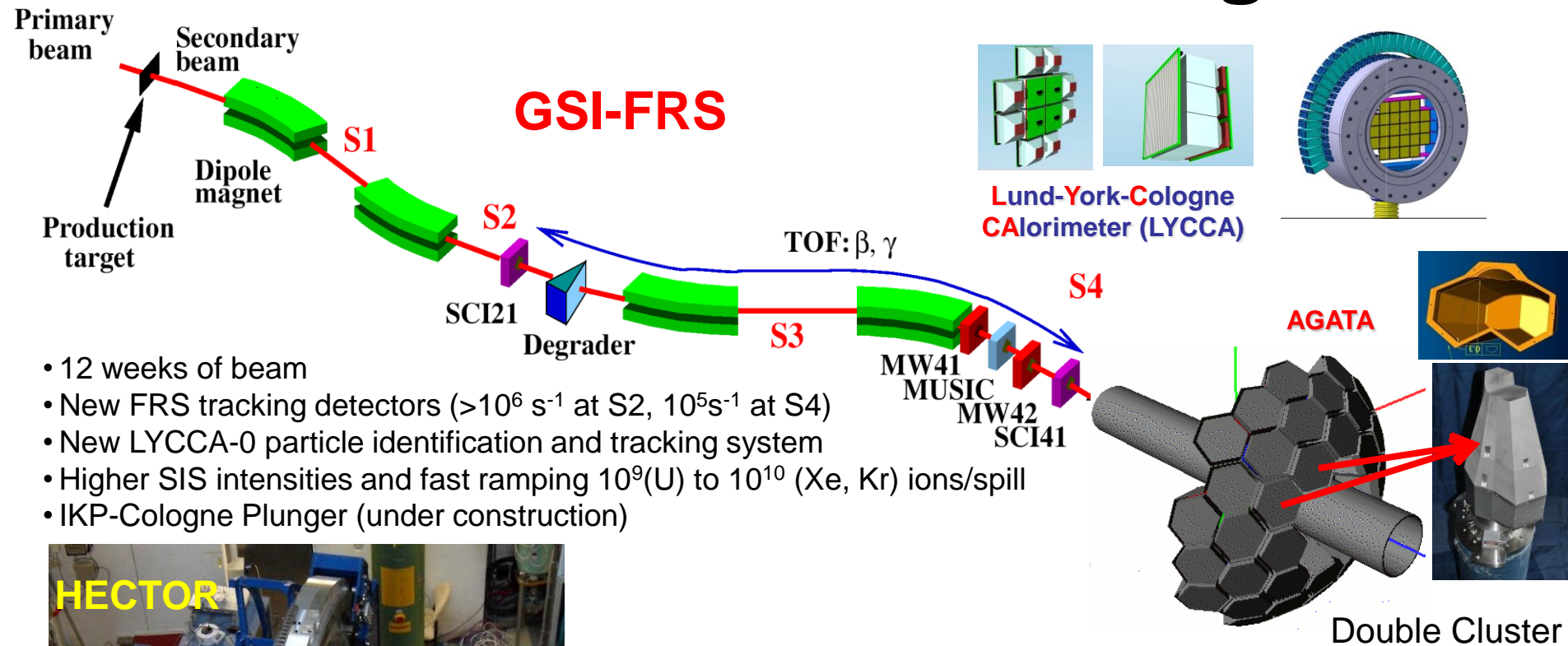

- 12 weeks of beam
- New FRS tracking detectors ($>10^6 \text{ s}^{-1}$ at S2, 10^5 s^{-1} at S4)
- New LYCCA-0 particle identification and tracking system
- Higher SIS intensities and fast ramping $10^9(\text{U})$ to 10^{10} (Xe, Kr) ions/spill
- IKP-Cologne Plunger (under construction)

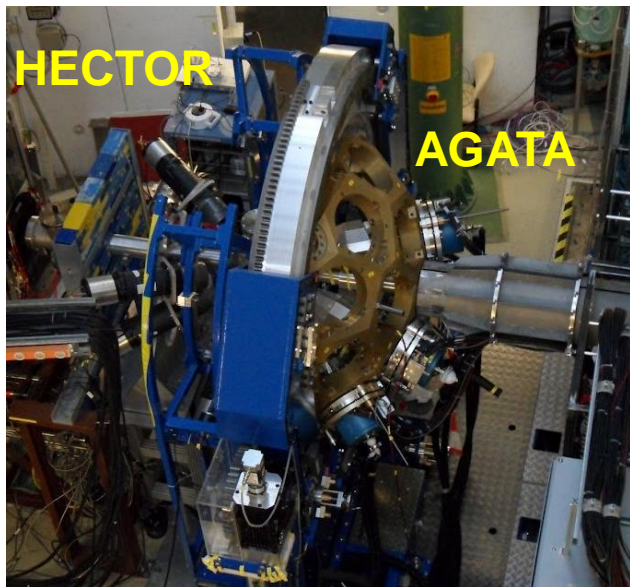

First part of GSI campaign ended [this morning](#) (21/11/2012)
 Four experiments performed, using up to 19 crystals:

- Coulomb Excitation of n-rich Pb, Hg and Pt isotopes
- Pygmy resonance excitation in ^{64}Fe ,
- Isomer Coulex in ^{52}Fe
- Lifetimes in the heavy Zr-Mo region

+ M1 excitation in ^{85}Br , ^{131}In + studies of HE background



The AGATA Collaboration

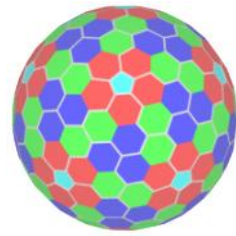

Bulgaria: Sofia

Finland: Jyväskylä

France: GANIL, Grenoble, Lyon, Orsay, Saclay, Strasbourg

Germany: Darmstadt, GSI, Köln, München

Italy: Firenze, LNL, Milano, Padova

Poland: Krakow, Warsaw

Romania: Bucharest

Spain: Valencia, Madrid, Salamanca

Sweden: Göteborg, Lund, Stockholm, Uppsala

Turkey: Ankara, Istanbul

UK: Brighton, Daresbury, Edinburgh, Liverpool, Manchester, Paisley, Surrey, York

First implementations of the γ -ray tracking array concept

AGATA Demonstrator

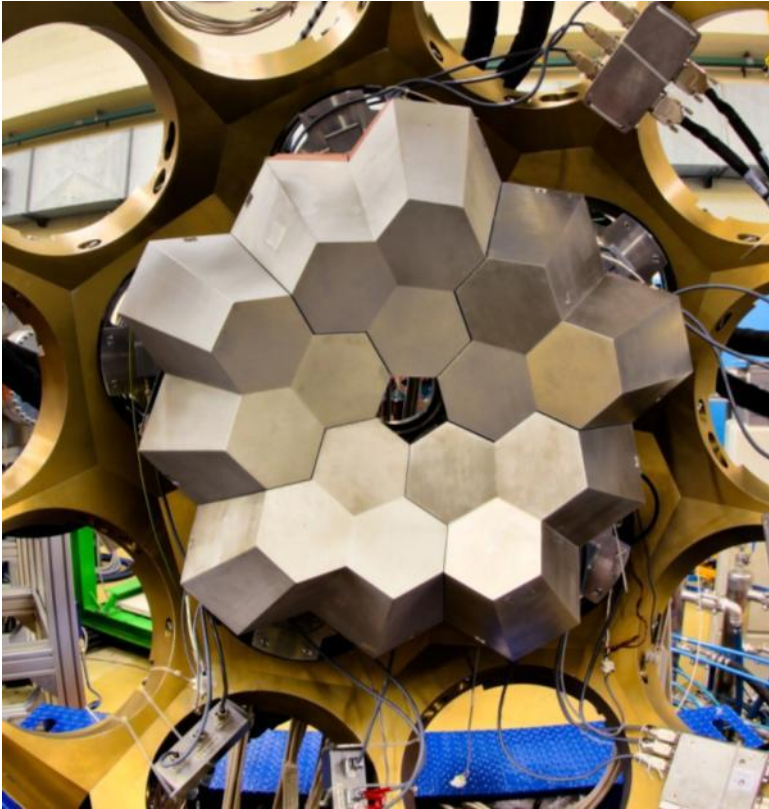

15 crystals in 5 Triple Clusters
Commissioned in 2009 at LNL (with 3 TC)
Experiments at LNL in 2010-2011
Now working at GSI with 20 crystals

GRETINA

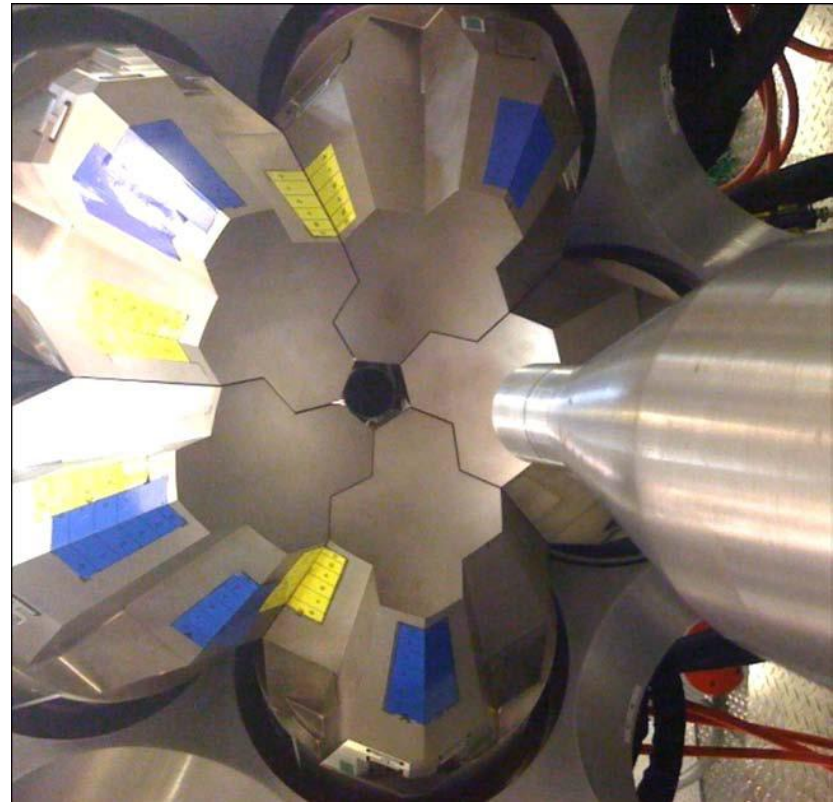

28 crystals in 7 Quadruple Clusters
Engineering runs started early 2011 at LBNL
Experiments at LBNL in 2011
Now working at NSCL