

# ISAPP 2003

## Observations of Cosmic Rays

- Examples of Air Shower Detectors

# Pierre Auger Observatory

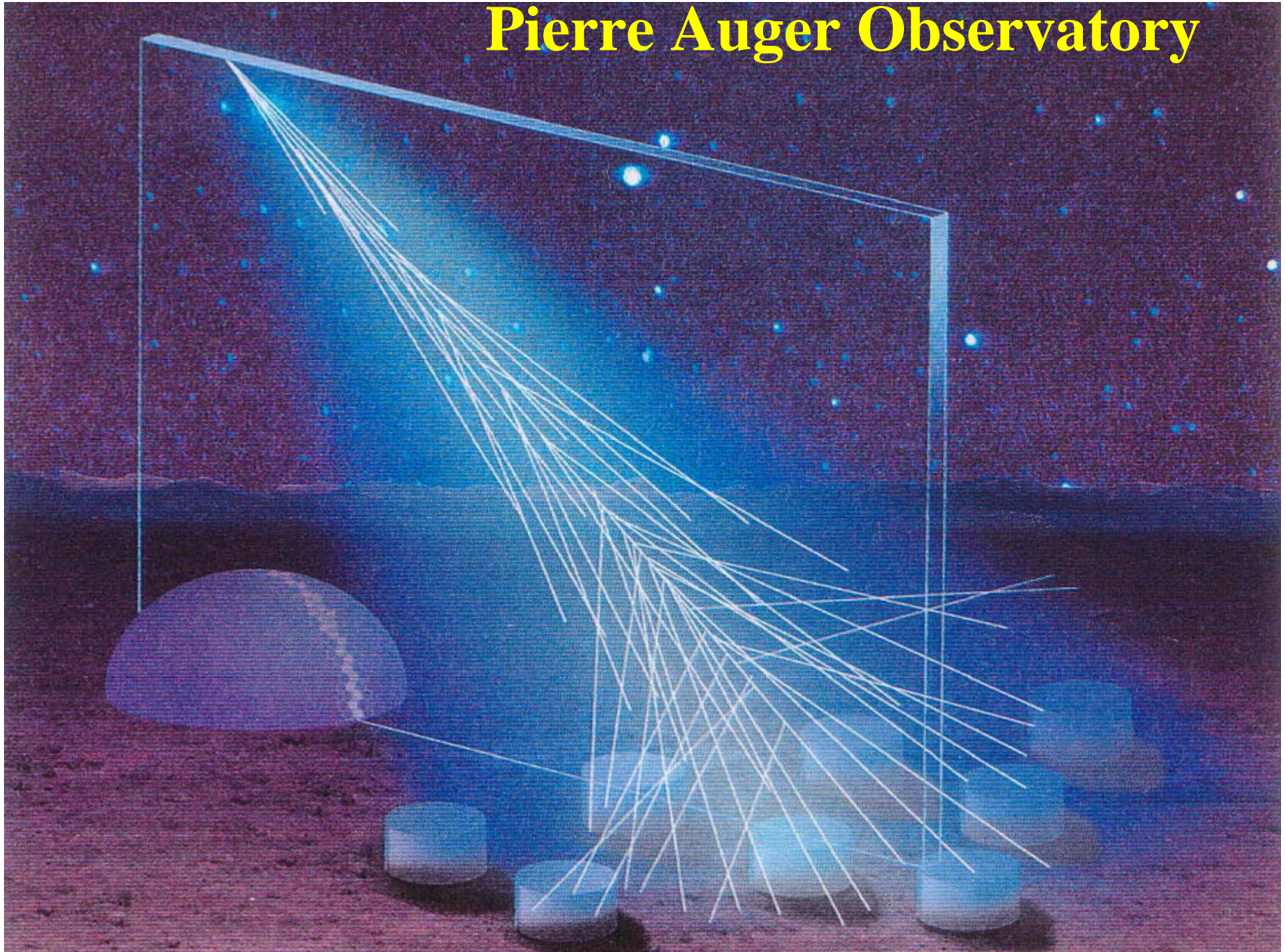

# Extended Air Showers

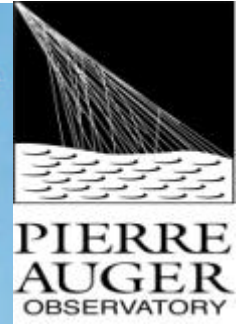

Pierre Auger Observatory:  
 $10^{19} \text{ eV} < E < 10^{21++} \text{ eV}$

- 1600 Water Cherenkov detectors
- 1.5 km spacing on 3000 km<sup>2</sup>
- 4 stations with 24 electronic telescopes

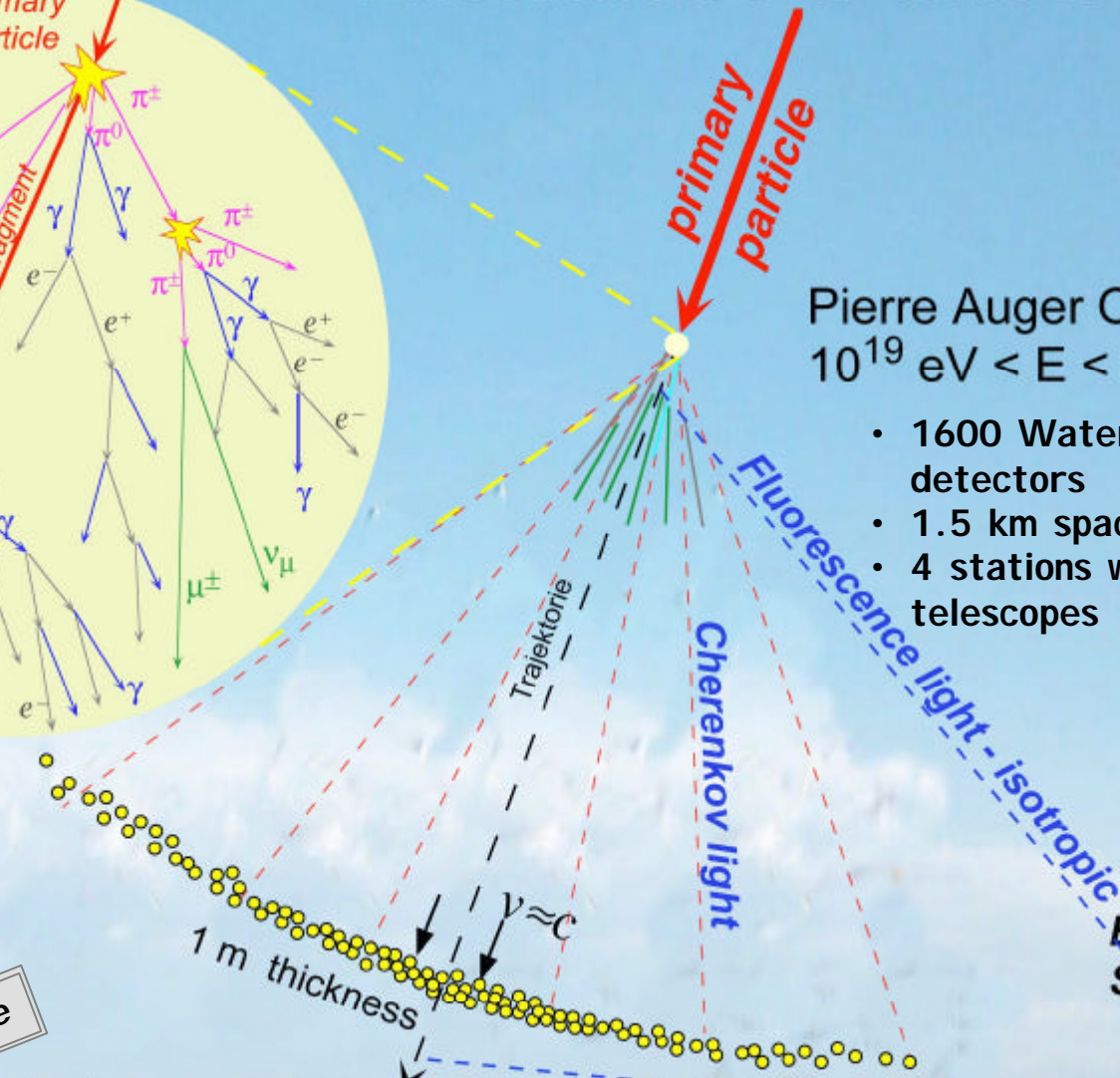
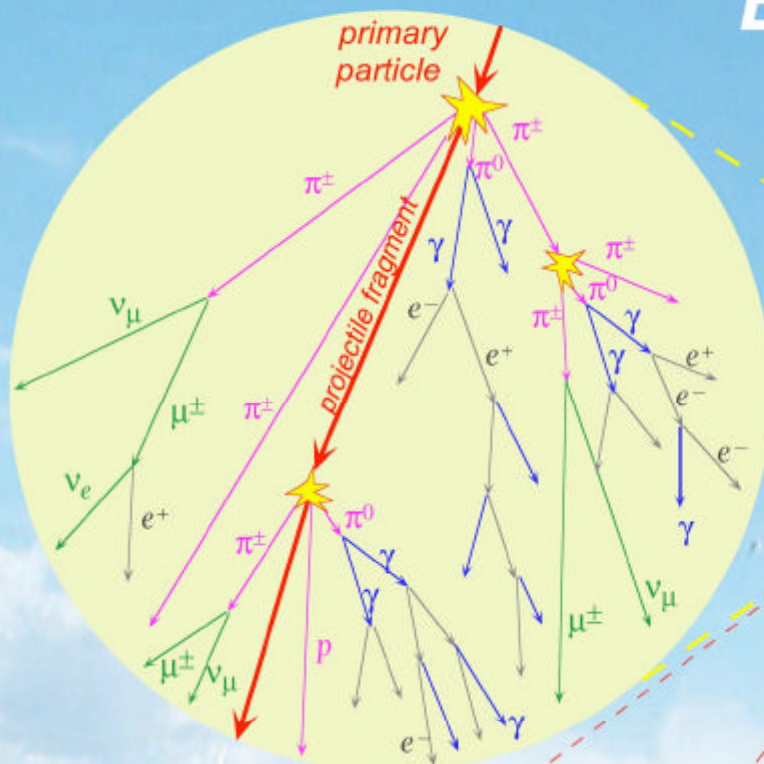

...not to scale

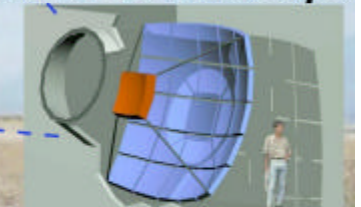
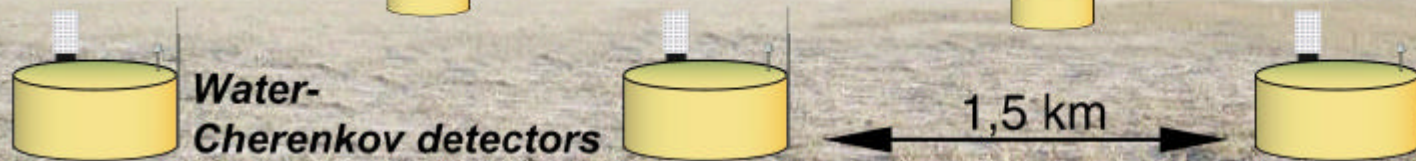

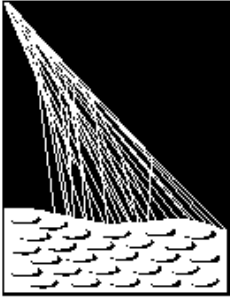

**PIERRE  
AUGER**  
OBSERVATORY

# Auger Surface Array

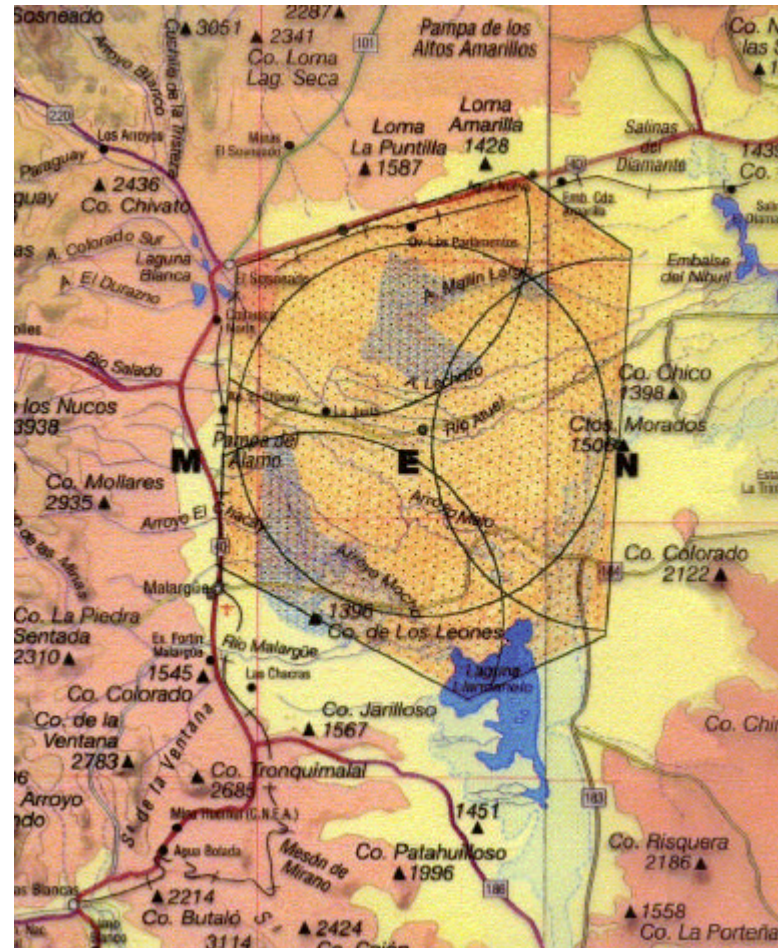

Tiina Suomijärvi, ISAPP 2003

# Surface Detector Station on the Pampa

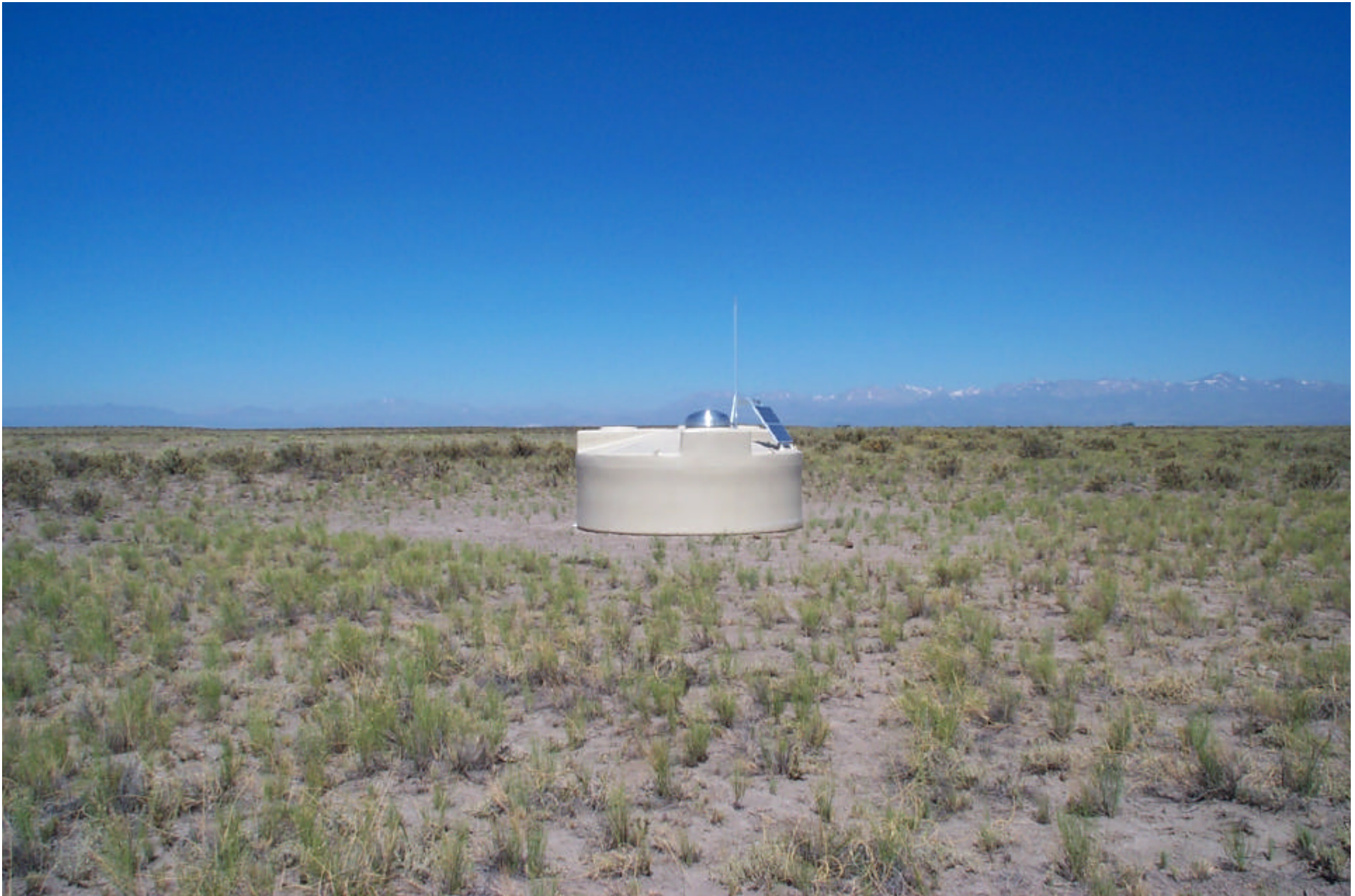

# Cherenkov Water Tank

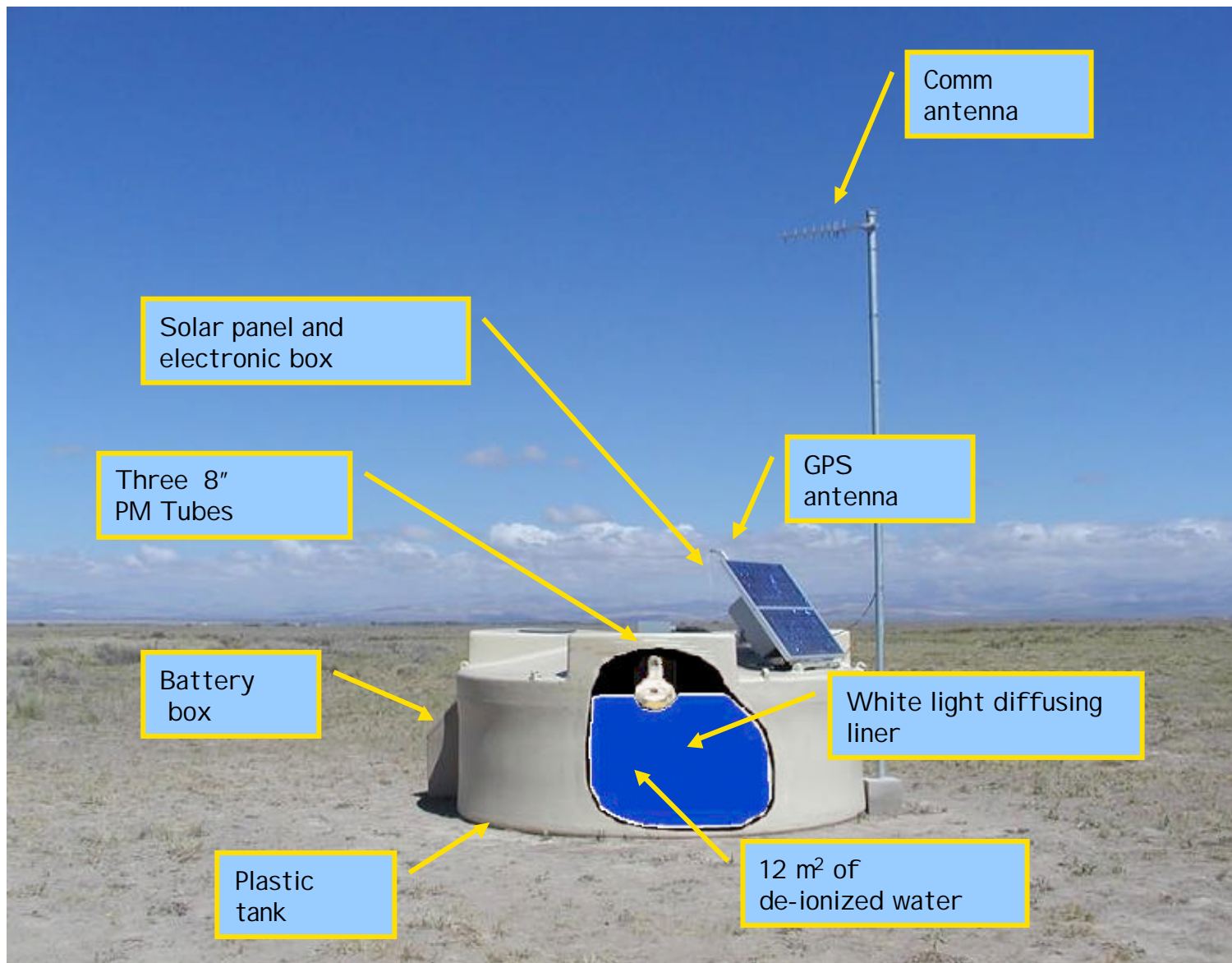

Tiina Suomijärvi, ISAPP 2003

# Water Tank Signals

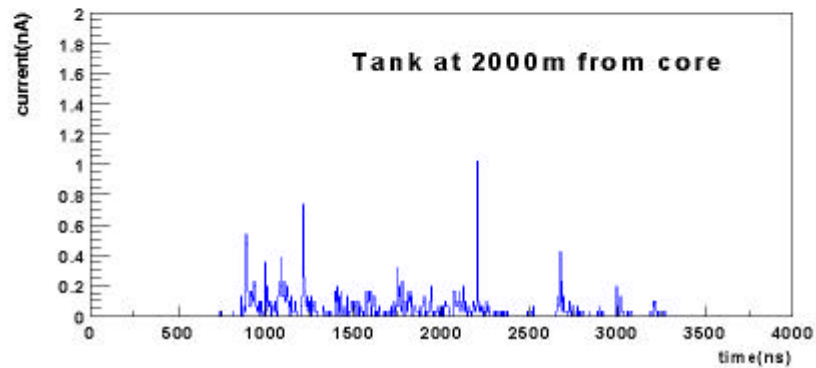
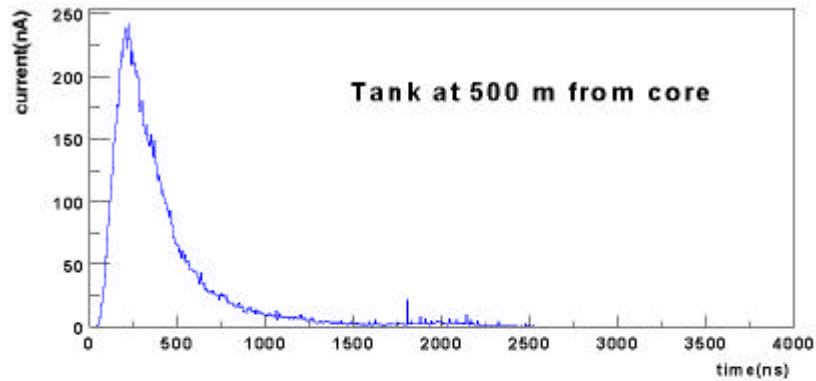

Proton,  $5 \cdot 10^{20}$  eV,  $30^\circ$

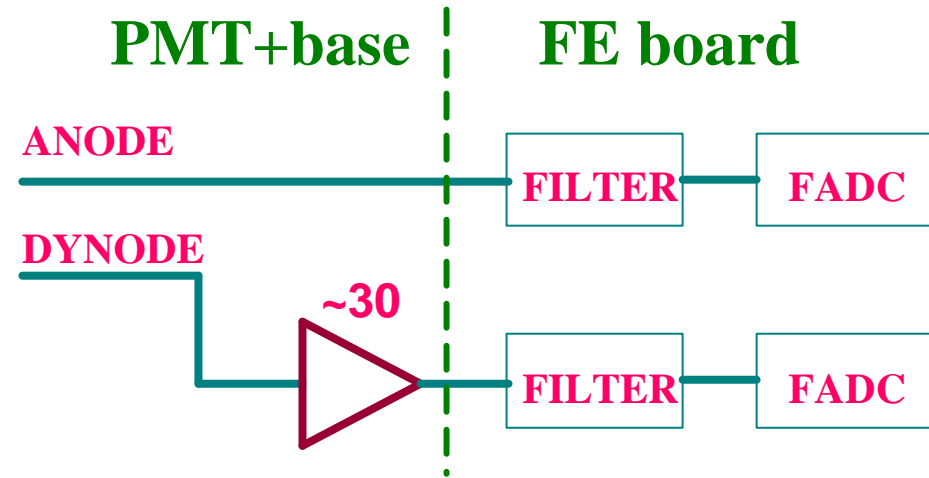

# Distributed Data Acquisition

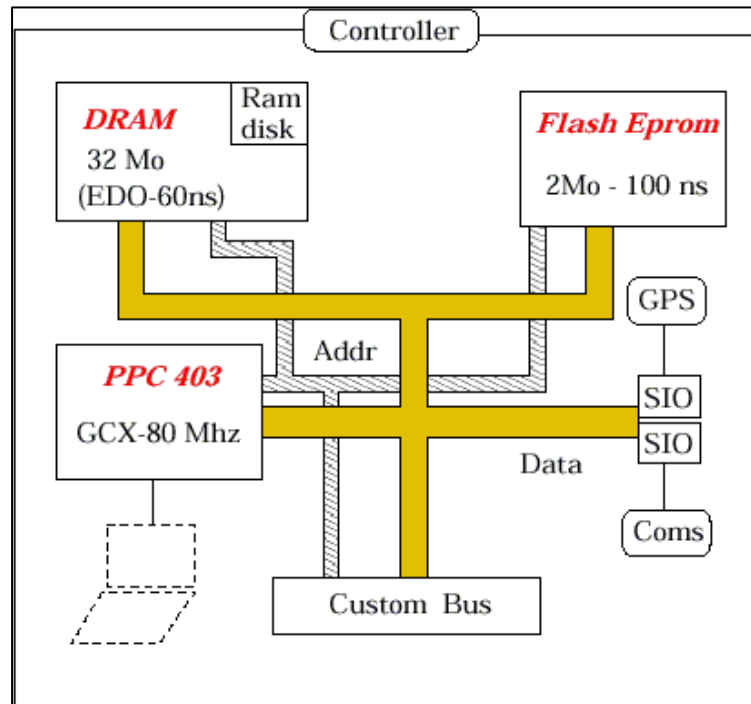

- ✓ Data from detector stations collected to FD stations through radio transmission: 1200 bits/s
- ✓ Data from each FD station send through microwave link to central station: 2 Mbits/s

## Local CPU and memory: station controller (OS9000)

- Second level trigger, data acquisition, calibration, slow control, receiving and sending data to Central Station
- Connections to GPS receiver, telecommunication unit and to tank power control board and to Ethernet card

# Surface Detector

## First 4 – fold event

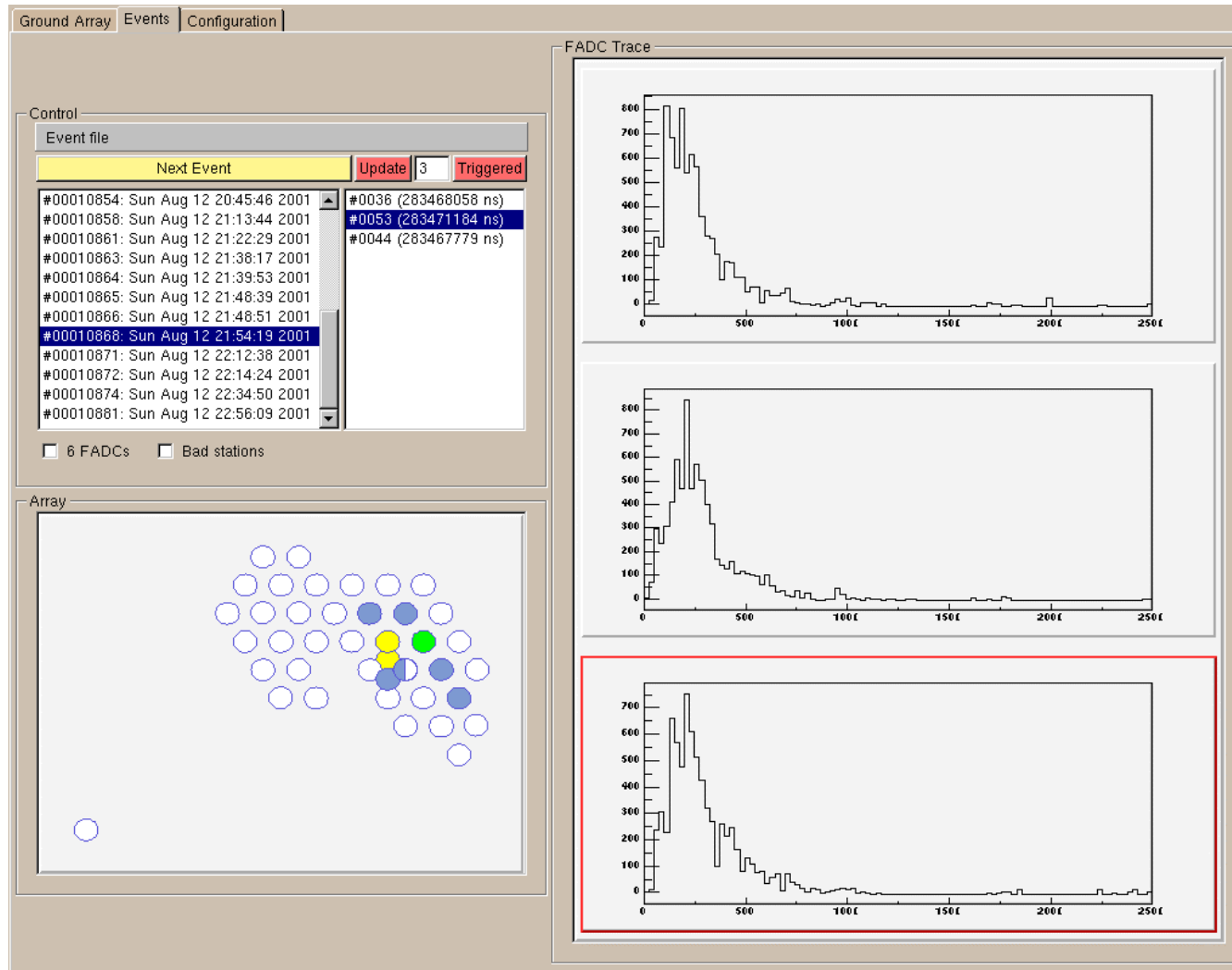

# Auger Fluorescence Detector

24 telescope units  
3.4 meter dia. Mirrors  
440 PMTs per camera

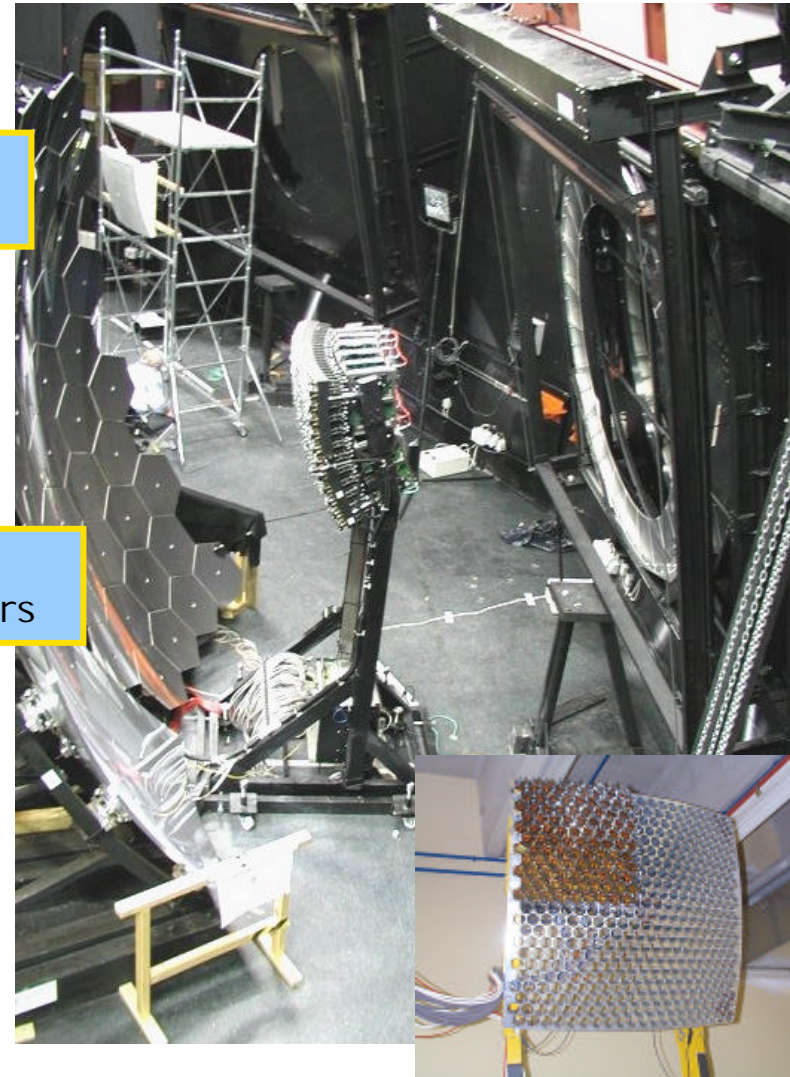
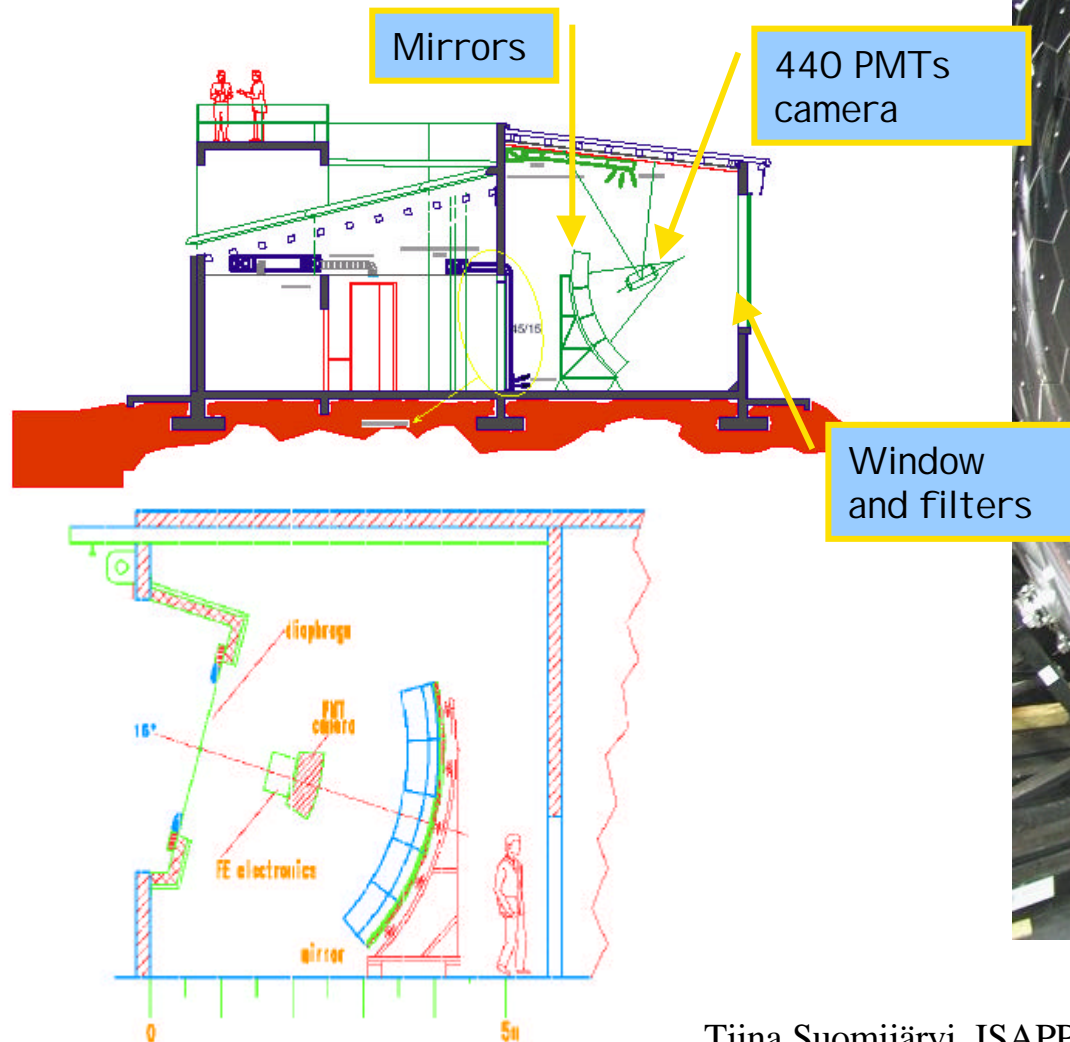

11m<sup>2</sup> segm. spherical  
Schmidt mirror,  
30° - 30°

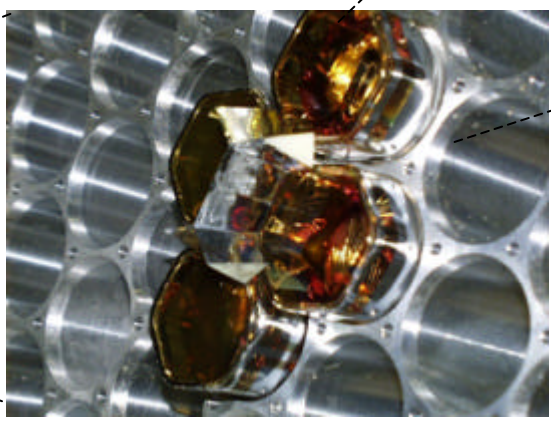
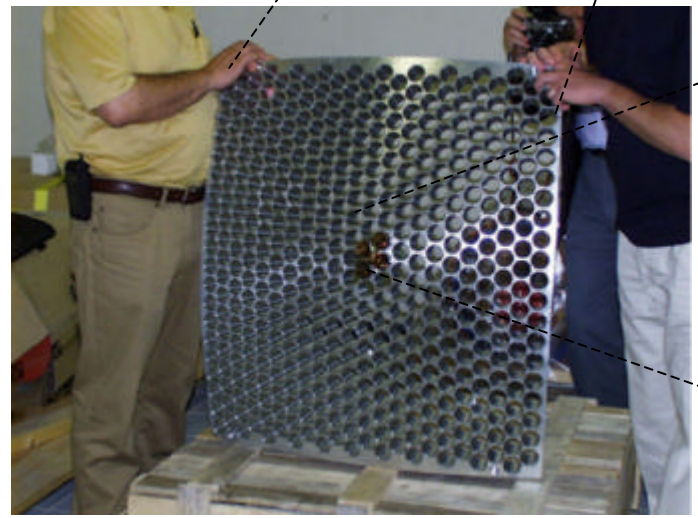
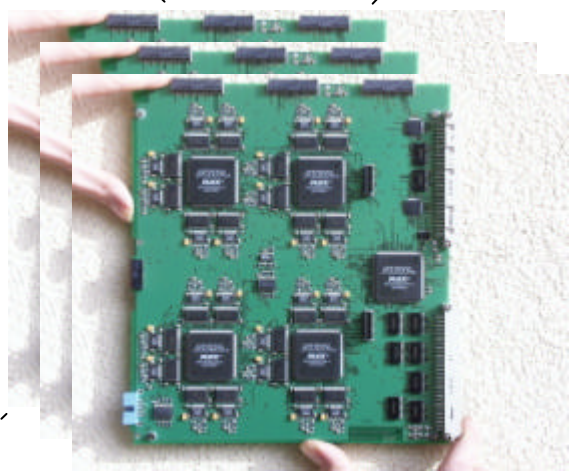
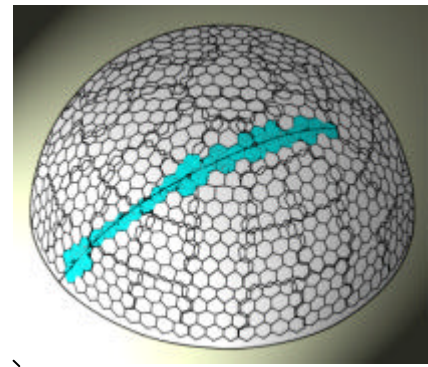
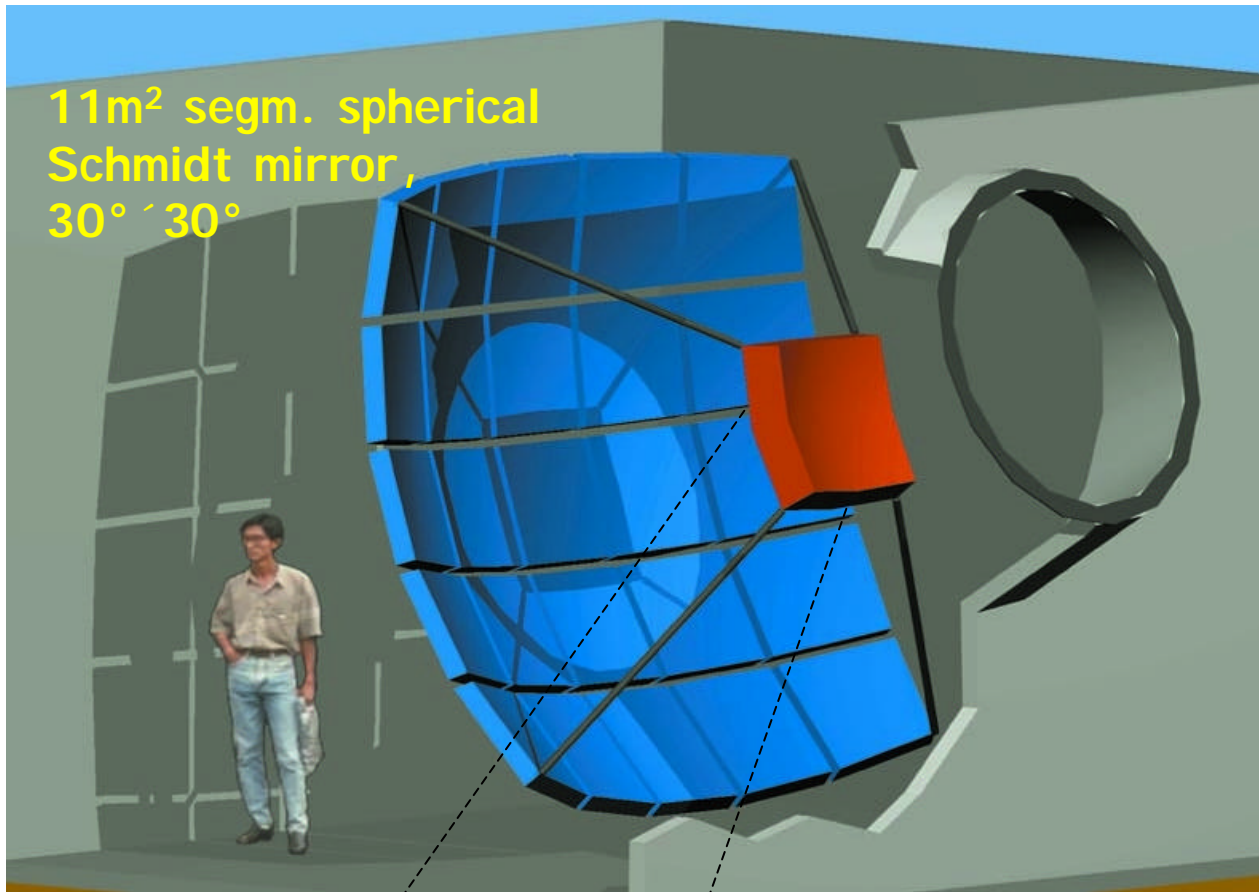

# Fluorescence Detector Building at Los Leones

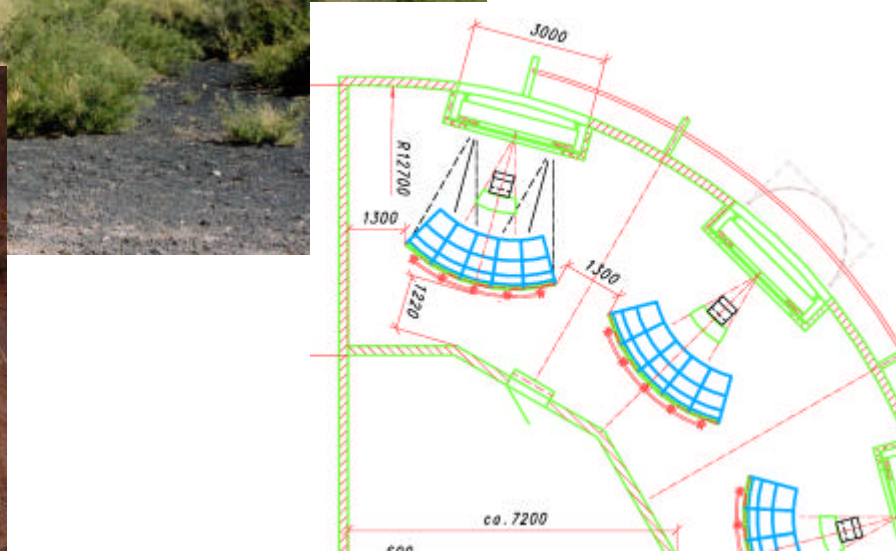

Tiina Suomijärvi, ISAPP 2003

# Fluorescence Detector Event

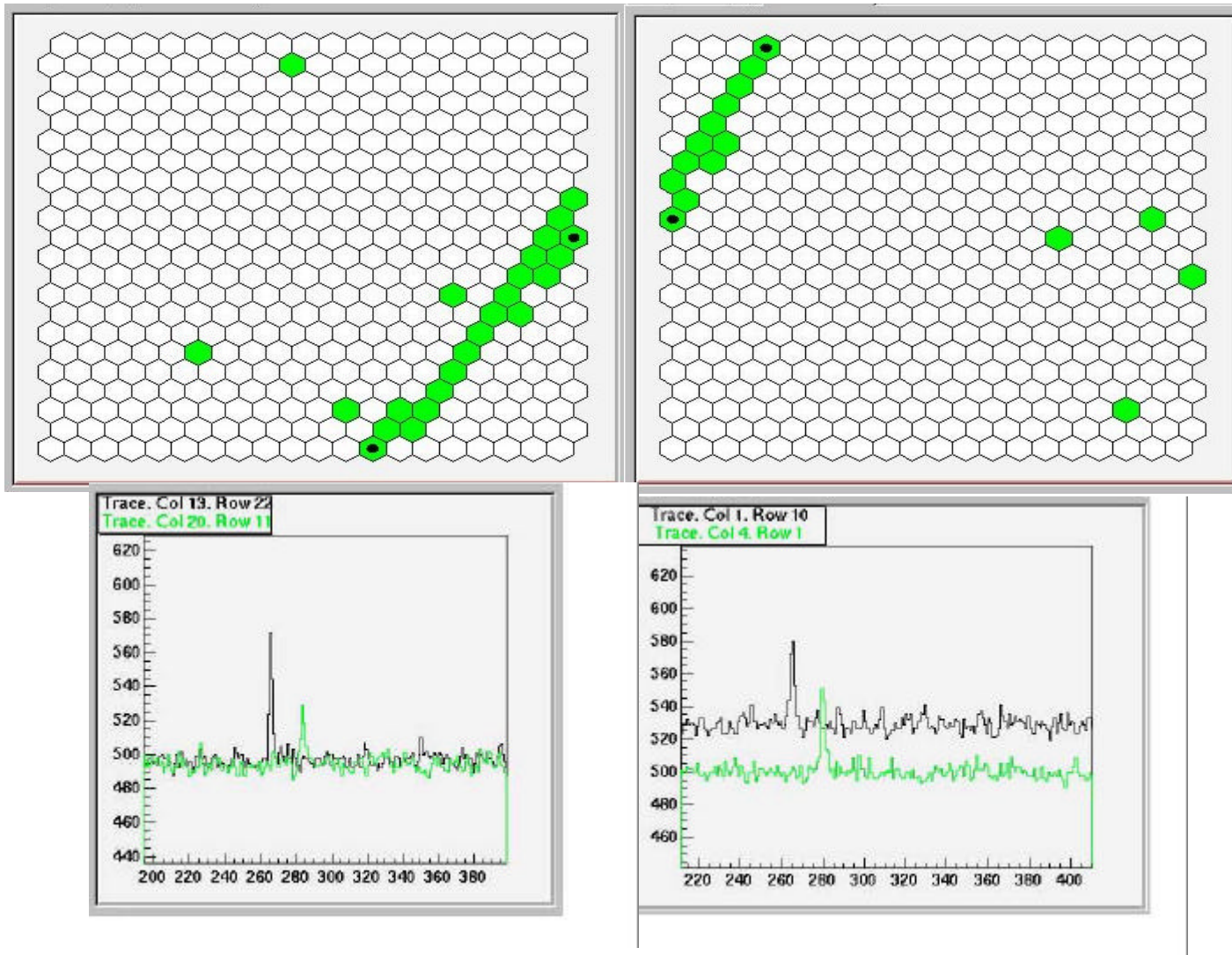

# Auger Atmospheric Calibration and Monitoring

- CORSIKA being upgraded to include Cherenkov and fluorescence
- balloon flights to check atmospheric profile
- LIDAR system
- Flashers, calibrated lamps, laser calibration of mirrors and PMTs... etc

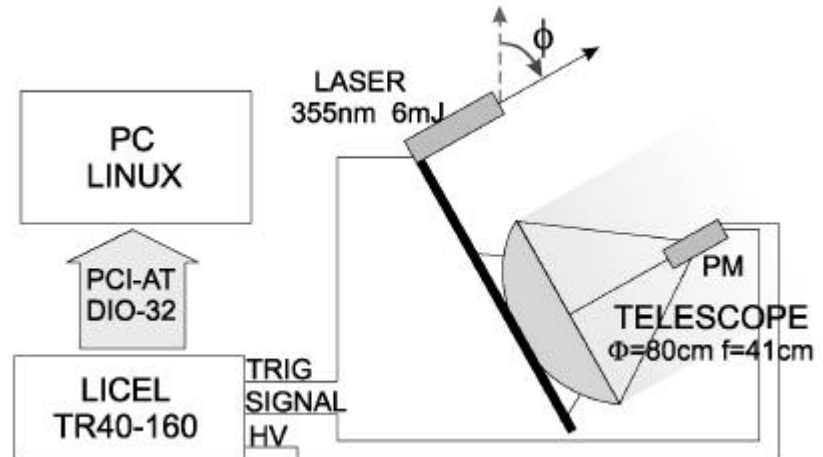
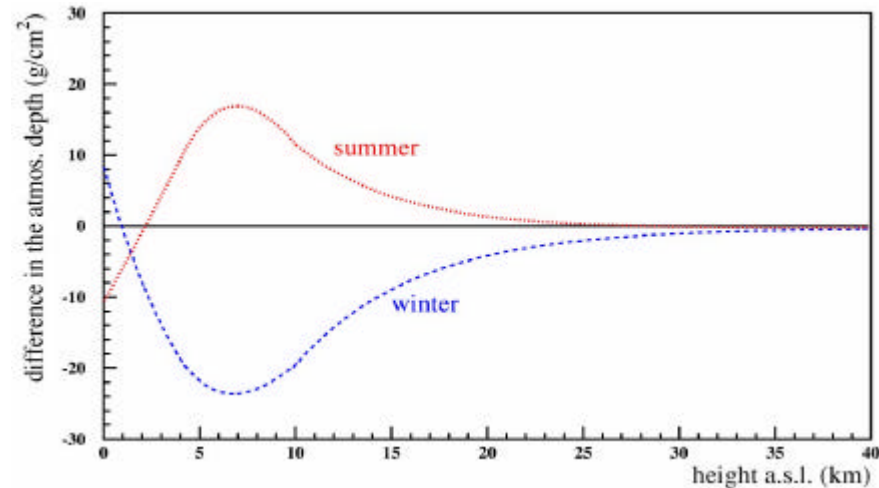

# Auger Performances

- On each site:
  - 1600 SD (surface detectors)
  - 4 FD eyes (fluorescence detectors)
- Duty Cycle: SD 100%
- Efficiency: >90% above 10 EeV
- FD 10% (only during clear moonless nights)
- Energy resolution:

	SD alone	Hybrid mode
100 EeV	15%	10%
10 EeV	30%	20%
- Angular resolution:

	SD alone	Hybrid mode
100 EeV	0.5°	0.20°
10 EeV	1.0°	0.35°

# EUSO

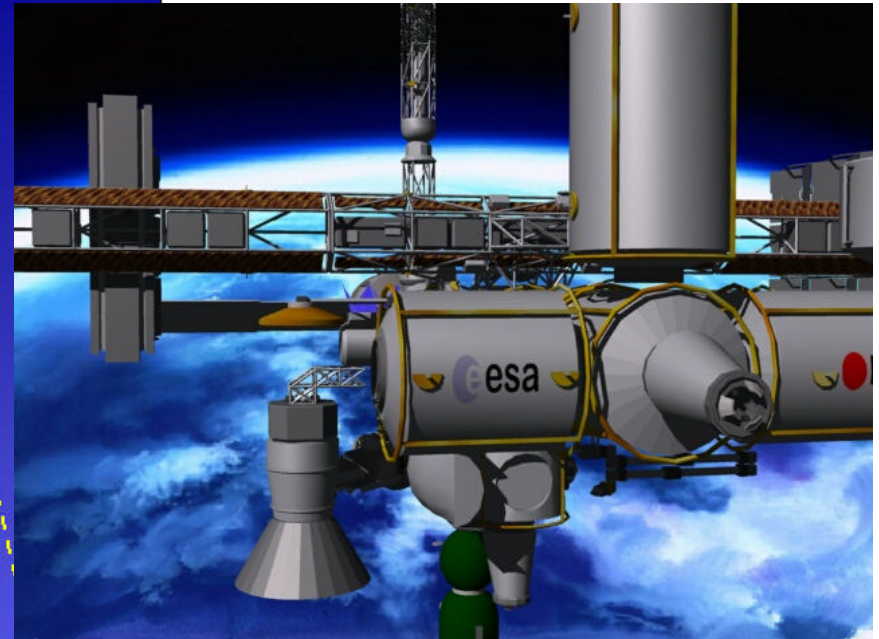
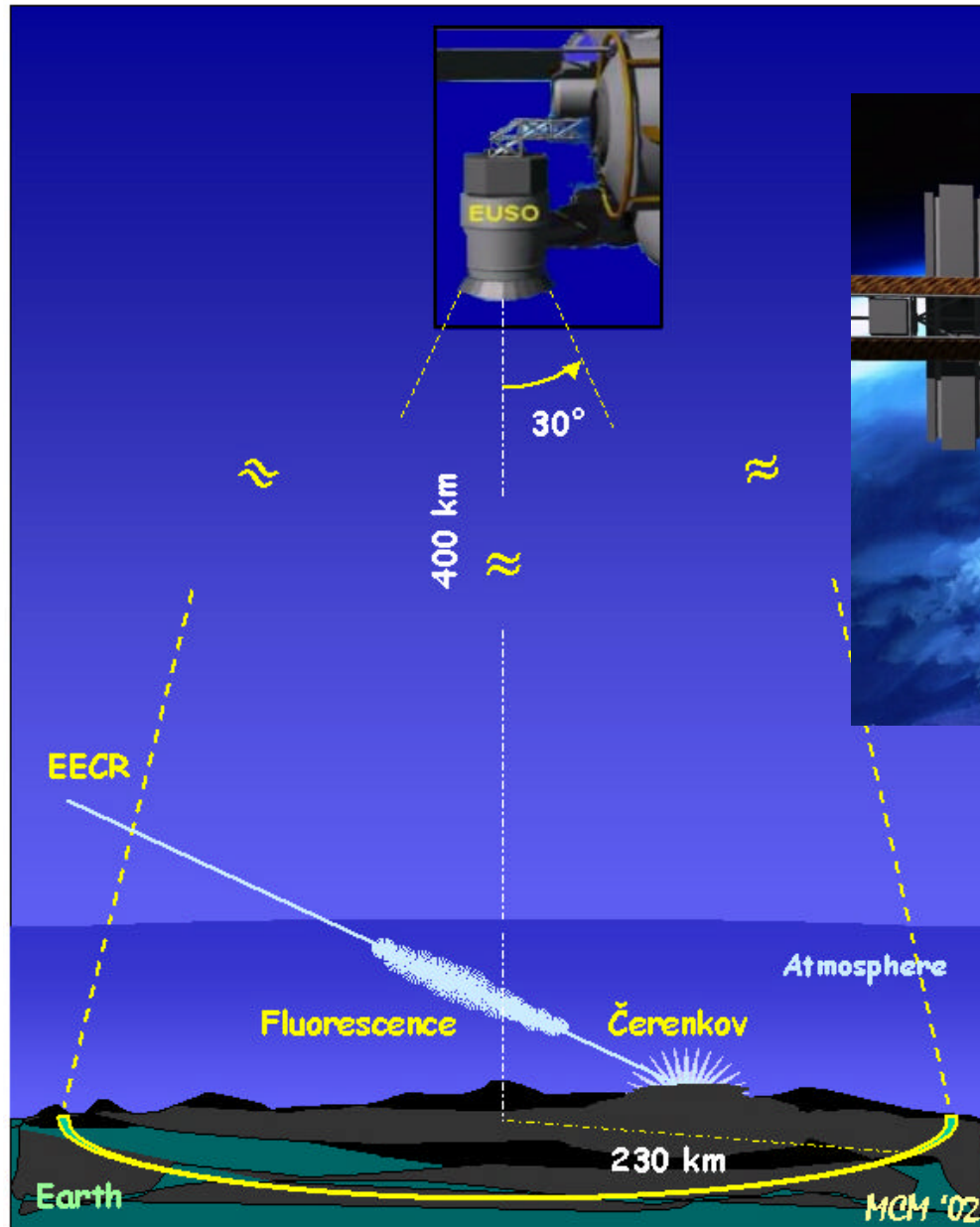

**ISS**  
**3 years starting 2008**

# Haverah Park

- 12 km<sup>2</sup> detector array of water cherenkov tanks
  - 20 years of operation until 1987
  - registered some 1000 air showers
  - energies up to 10<sup>20</sup> eV...

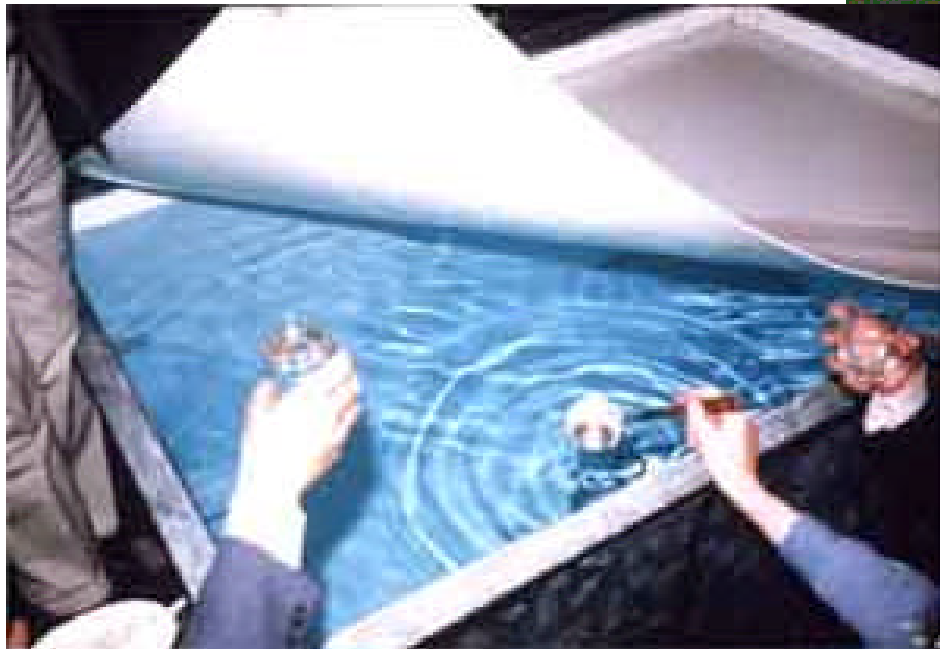

*water tasting after  
20 years: „a little bit  
stale...”*

# One of the 100 EeV Events at Haverah Park

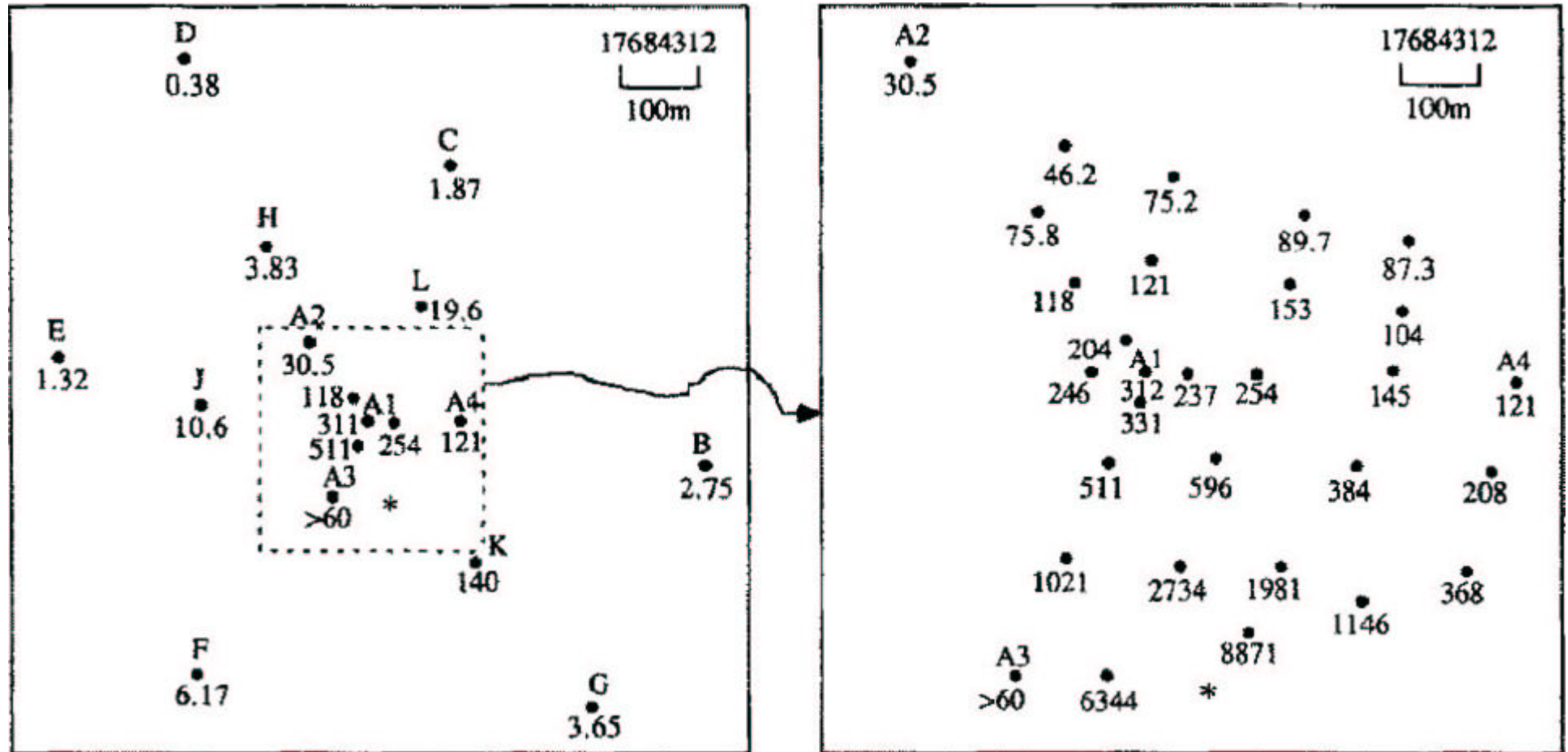

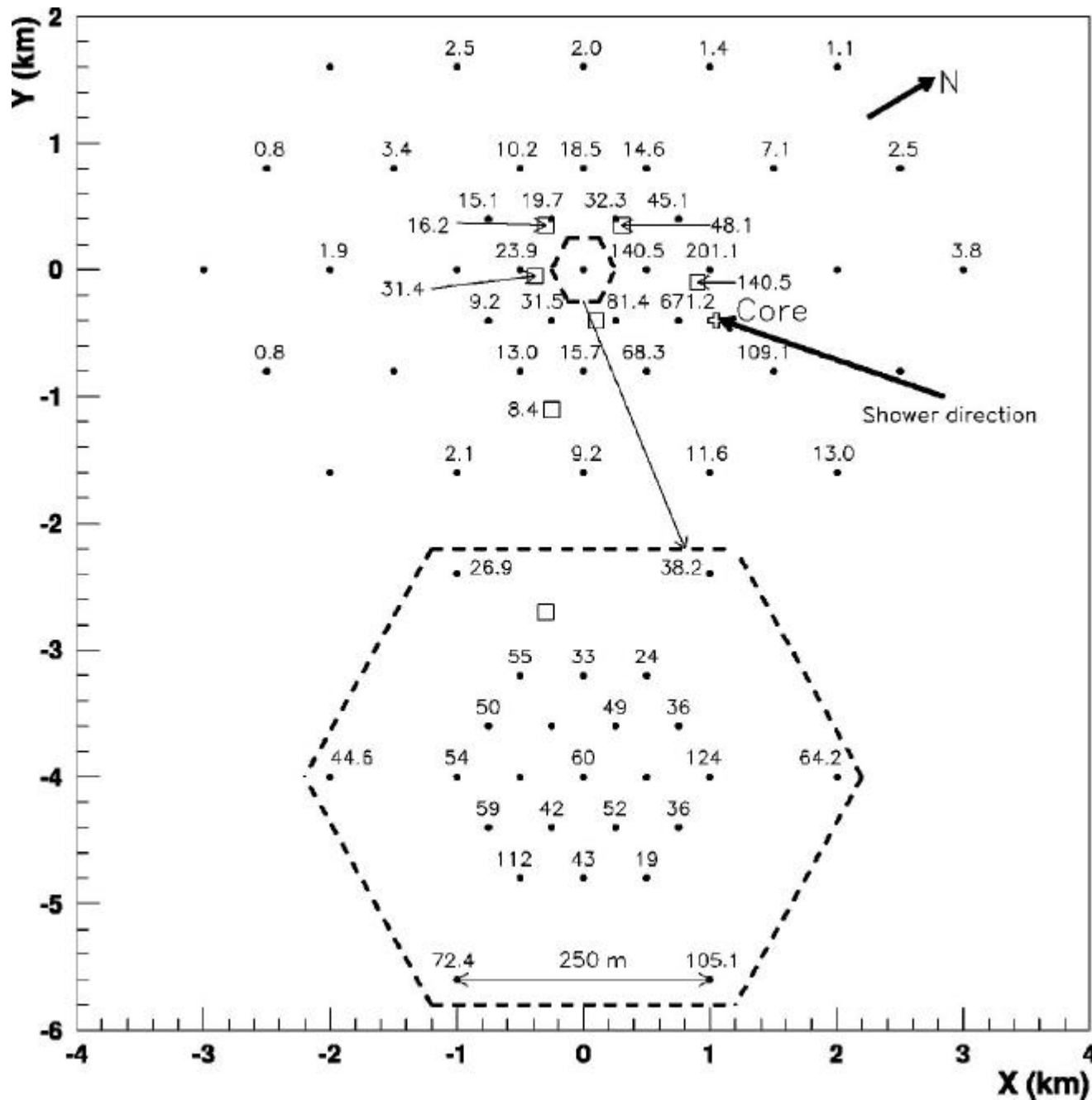

# Yakutsk Event of 100 EeV

Siberia

**Volcano Ranch**, New Mexico, 1960+:  
first event with  $E > 10^{20}$  eV



## Linsley's Event of 130 EeV

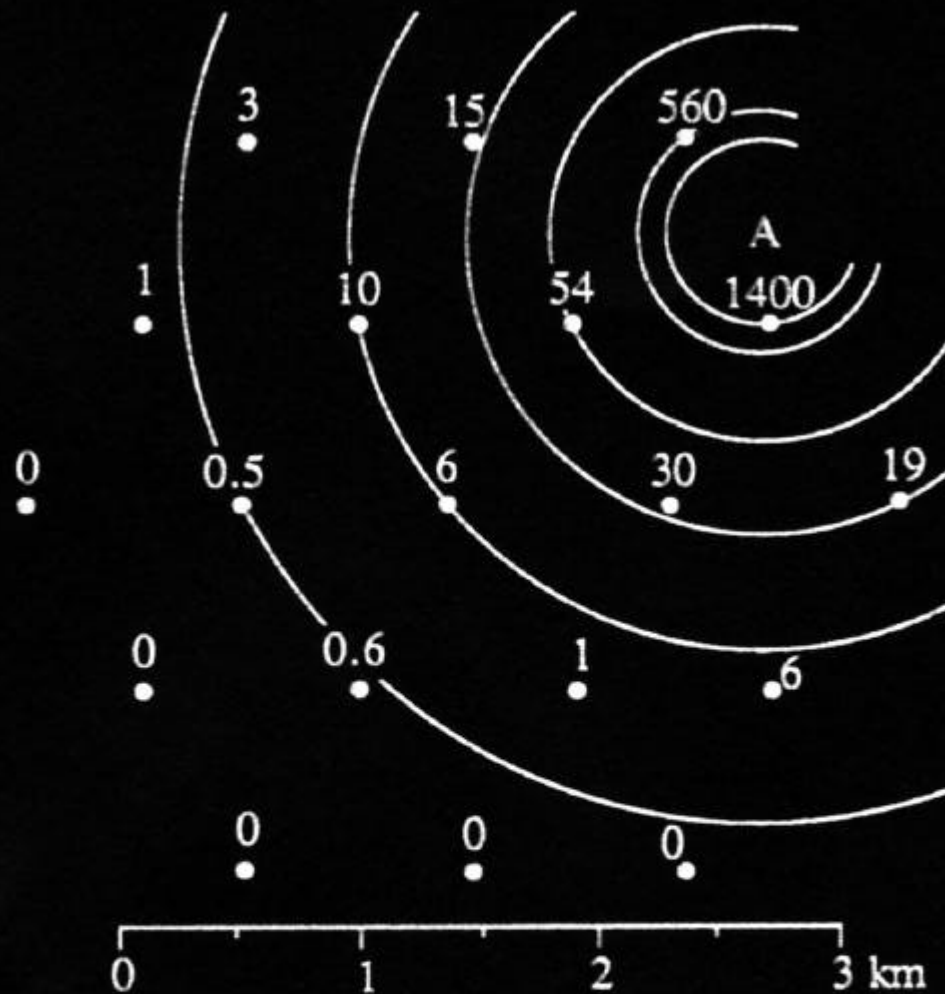

FIGURE 1

The first event<sup>1</sup> claimed to be due to a primary cosmic ray of  $10^{20}$ eV. The black dots are  $3.3\text{m}^2$  detectors on a 884m grid. The circles are contours of equal density: A marks the core.

# The Fly's Eye in UTAH

- pure fluorescence detector



# The Fly's Eye in UTAH

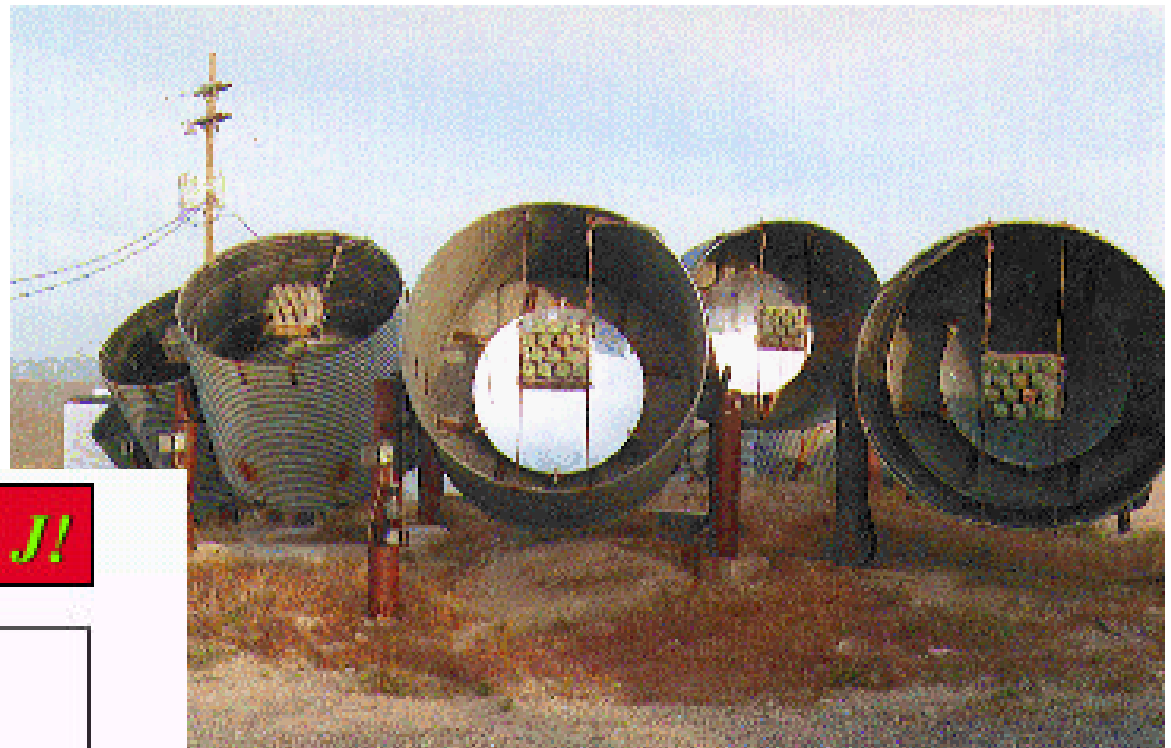

$$E = 3 \times 10^{20} \text{ eV} \quad 50 \text{ J!}$$

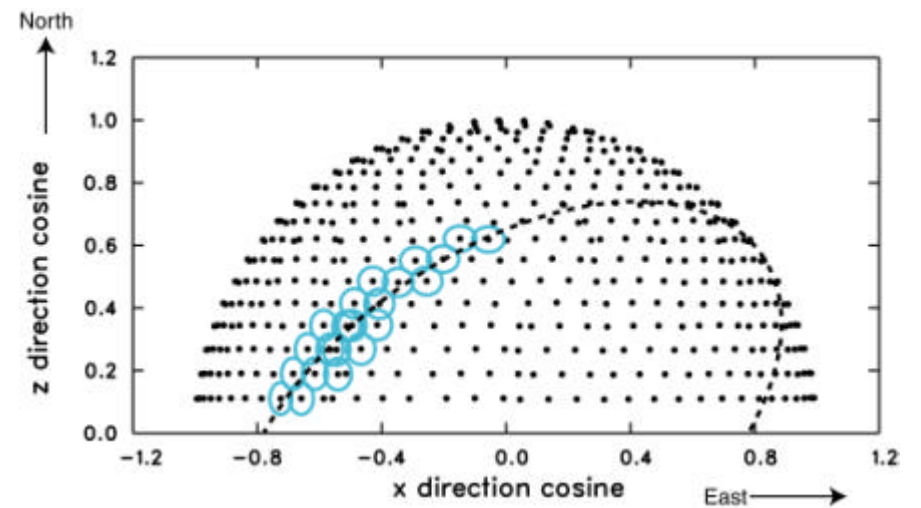
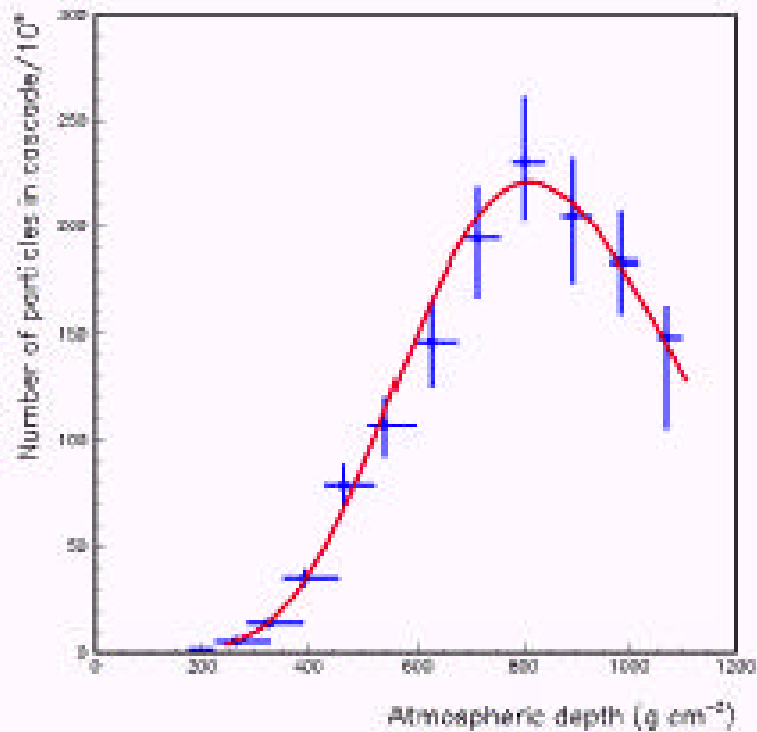

# High Resolution Fly's Eye: HiRes



- 21 Mirrors
  - 360 deg in azimuth
  - 3-17 deg in elevation
- Sample & Hold DAQ
- Began observation: June 1997



- 42 Mirrors
  - 360 deg in azimuth
  - 3-33 deg in elevation
- FADC DAQ
- Began observation: October 1999

# HiRes Stereo Event

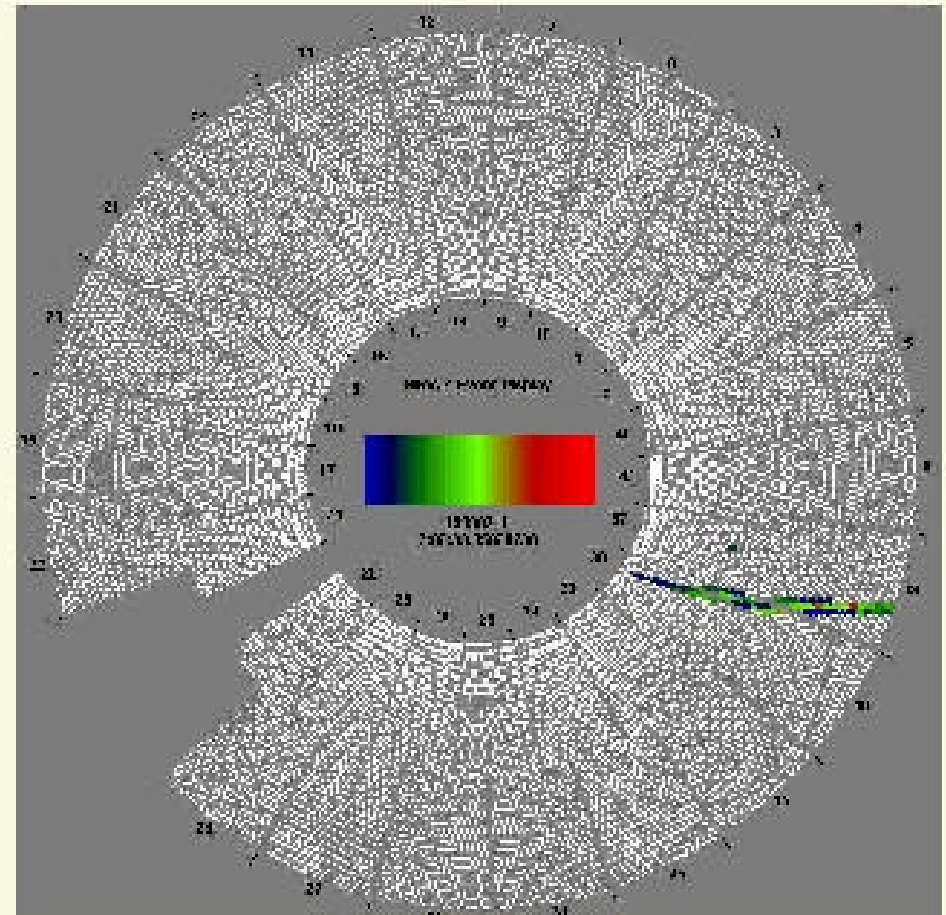
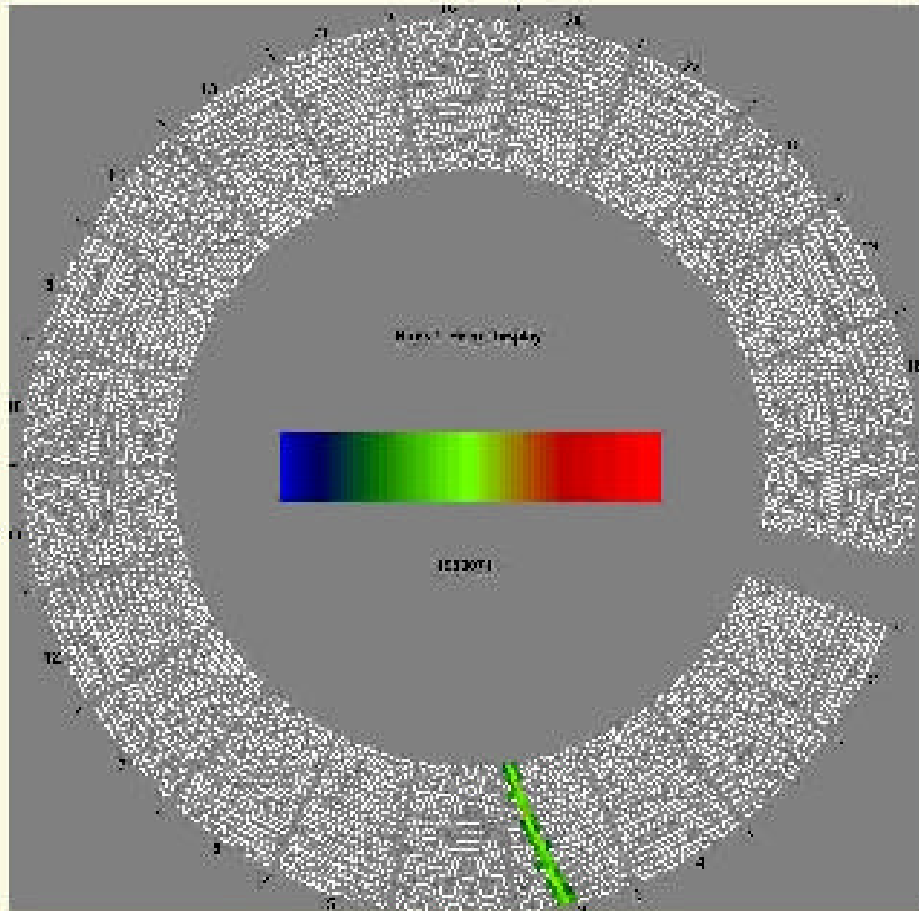

*Typical event:* July 11, 1999

# AGASA

## Akeno Giant Air Shower Array

100 km<sup>2</sup> in Japan  
Scintillator technique  
111 Electron detectors  
27 Muon detectors

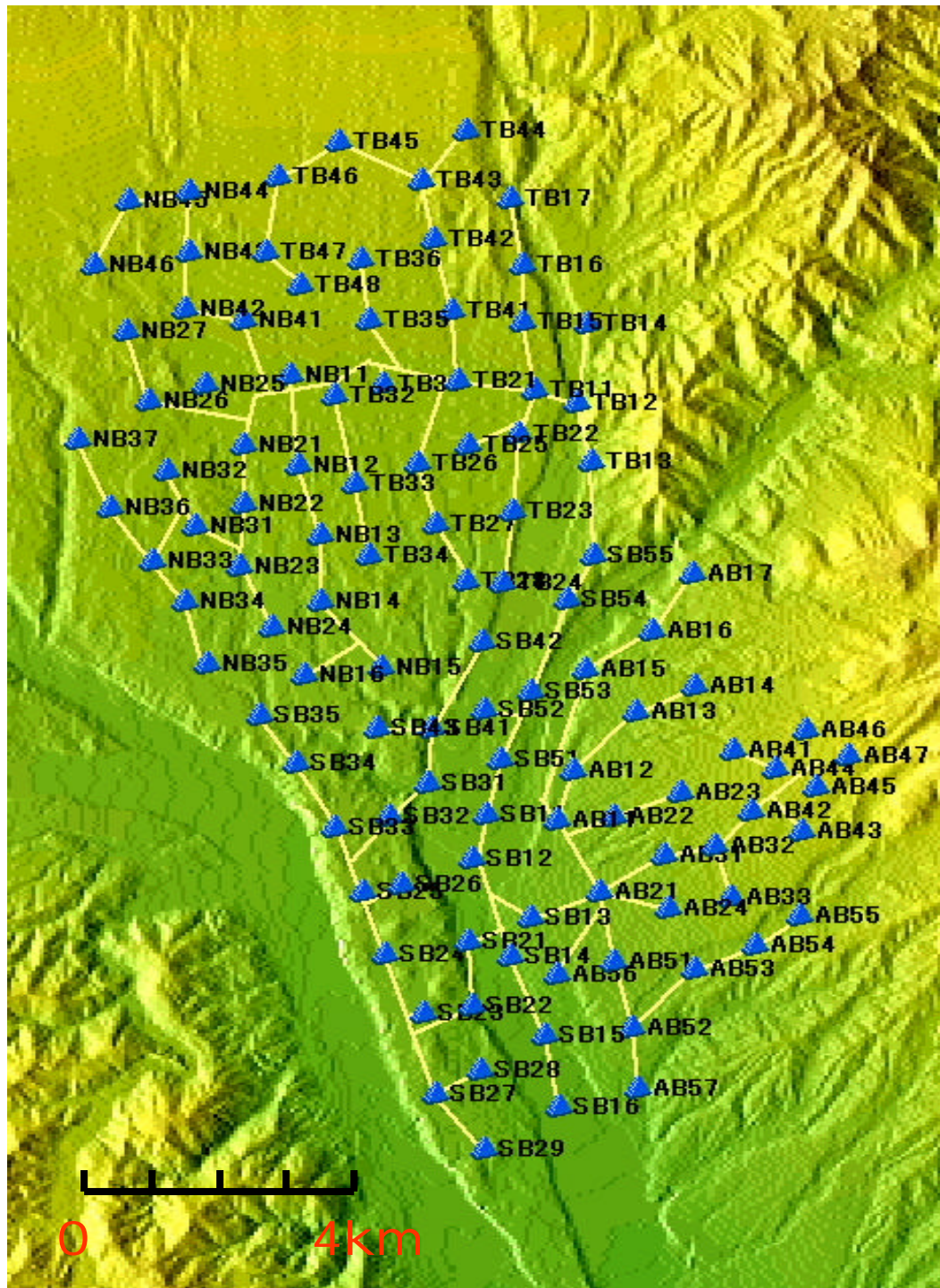

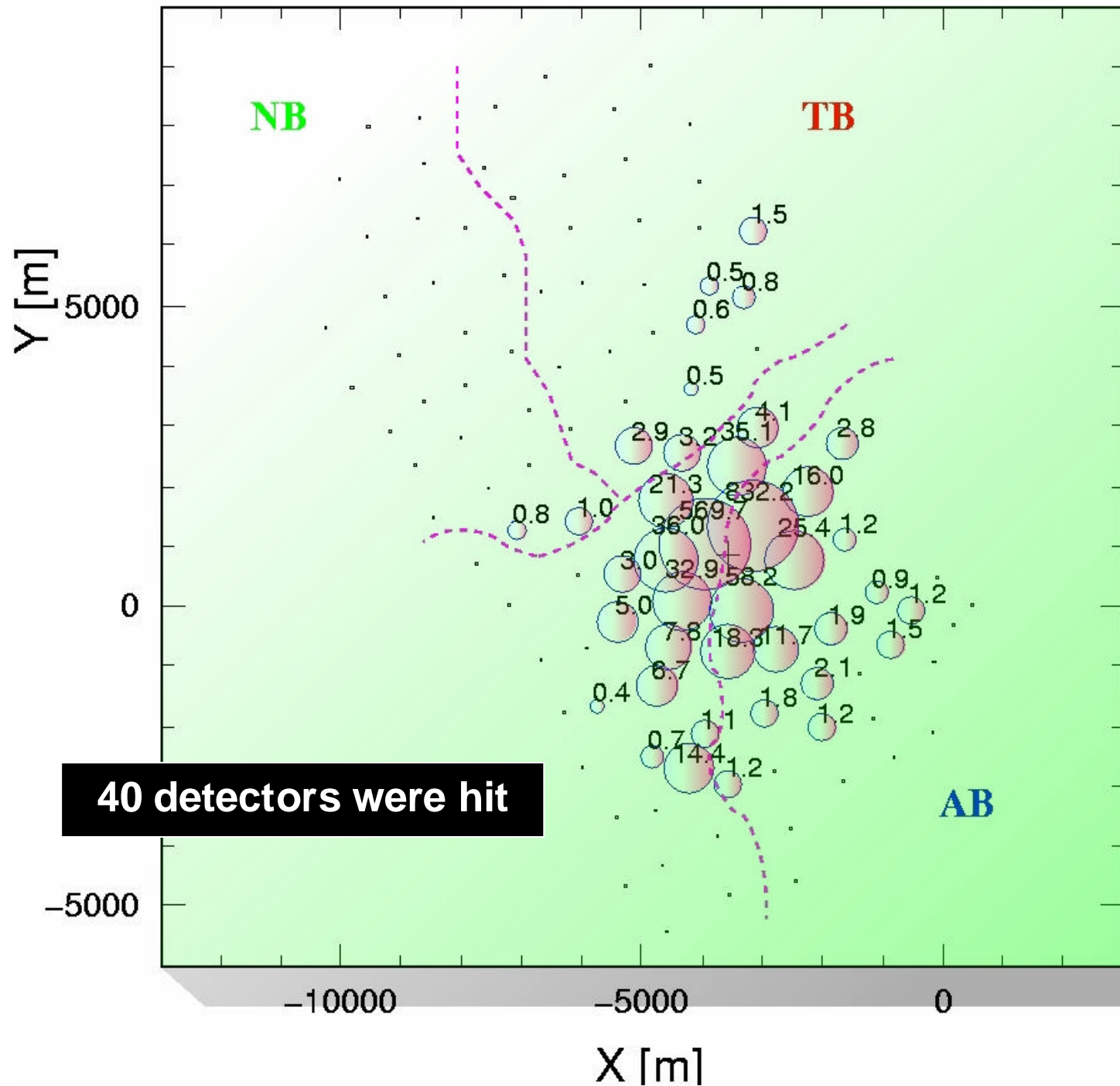

**Third  
Highest  
Event**  
**97/03/30**  
**150EeV**

# EAS-TOP

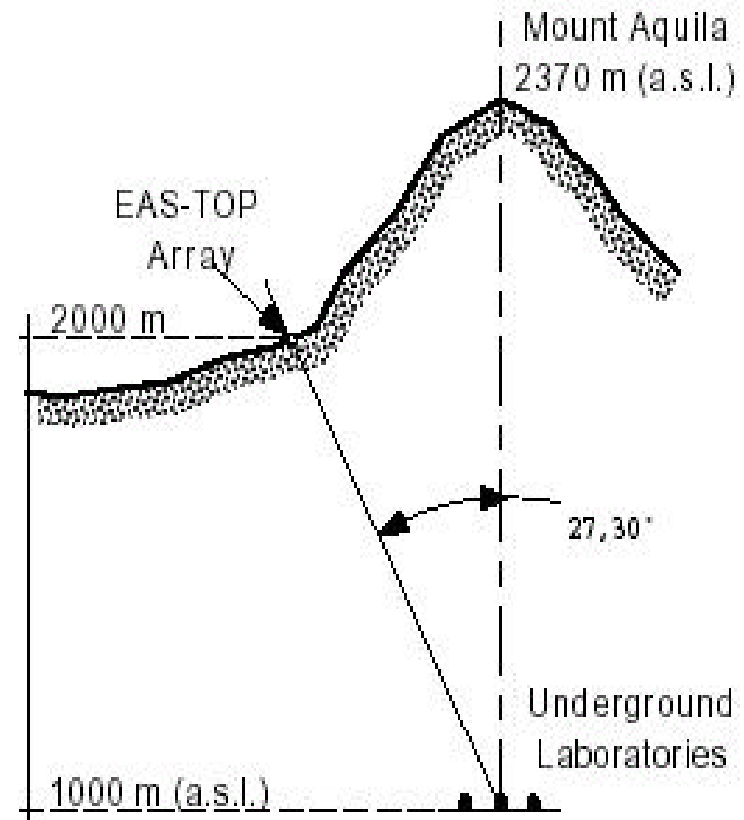
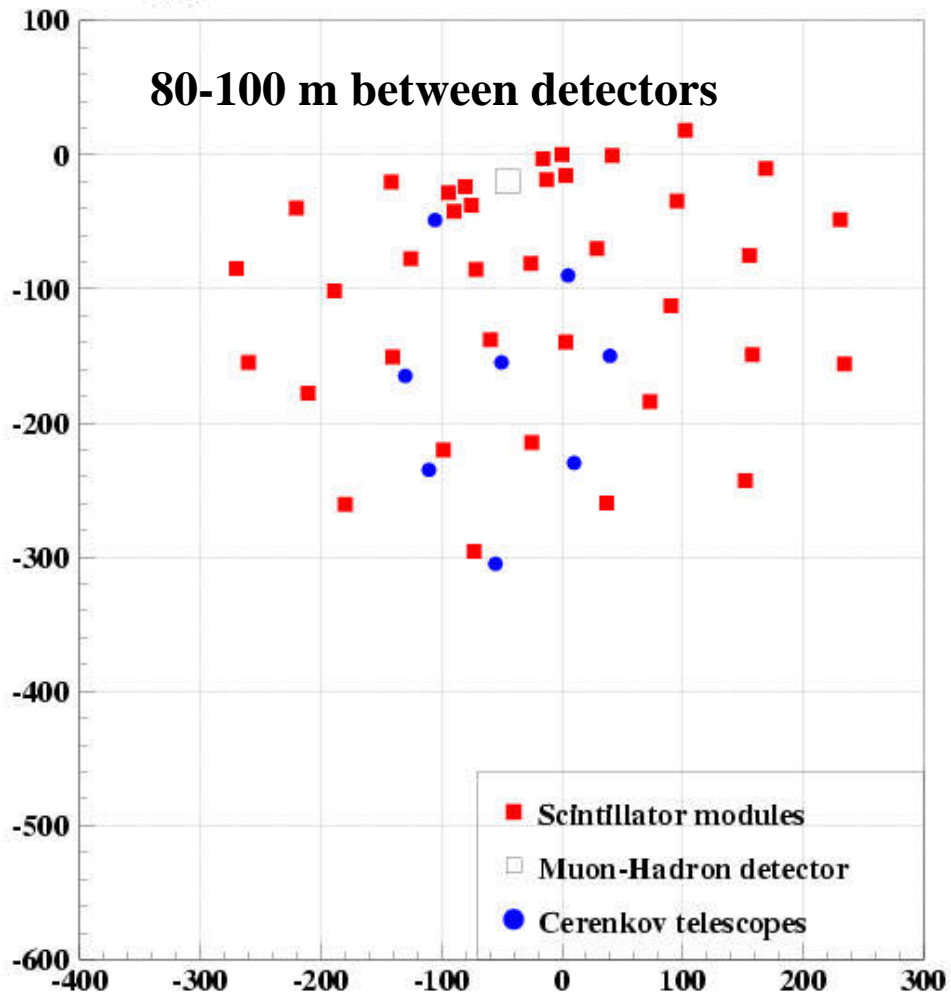

$10^{14} - 10^{16}$  eV  
Surface area  $10^5$  m<sup>2</sup>



Cherenkov stations

## EAS-TOP

Scintillators



Tiina Suomijärvi, ISAPP 2003

# EAS-TOP - MACRO

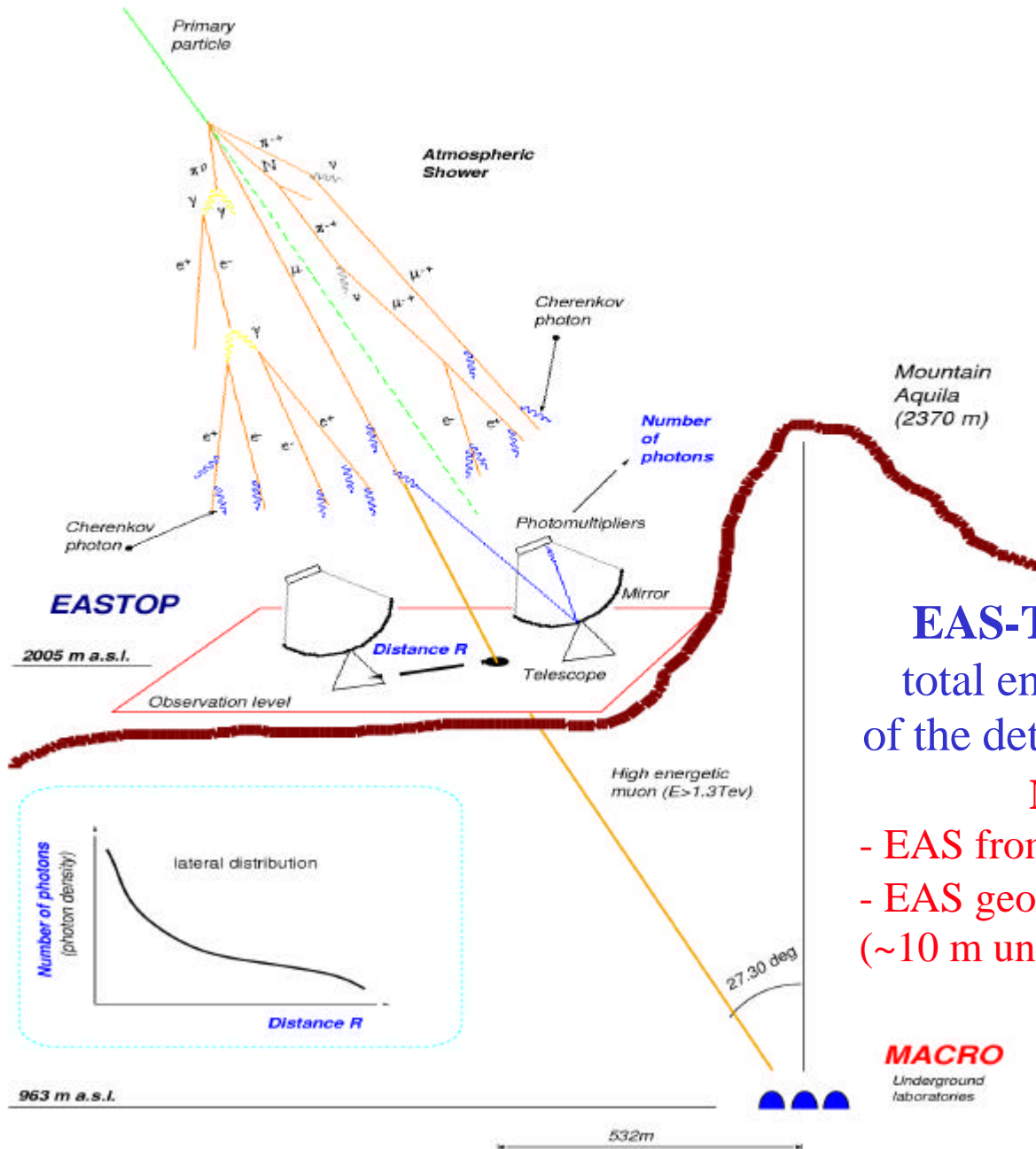

MACRO and EAS-TOP are separated by 1100 - 1300 m of rock corresponding to a threshold  $E_{\mu} \approx 1.3 - 1.8 \text{ TeV}$ .

**EAS-TOP** (Cherenkov detector): total energy through the amplitude of the detected Cherenkov light signal.

**MACRO** (as a  $\mu$  detector):

- EAS from primaries with  $E_n > 1.3 \text{ TeV}$
- EAS geometry through the  $\mu$  track (~10 m uncertainty for core location).

# KASCADE-Grande

includes EAS-TOP scintillators

- Forschungszentrum Karlsruhe in Germany.
- It measures simultaneously the electromagnetic, muonic and hadronic components of extensive air showers.
- The goal is the determination of the chemical composition of primary particles of cosmic rays around and above the "knee,, ( $10^{15}$ - $10^{18}$  eV)



## Radiodetection !



# ARGO



**Detection of gamma rays**  
**100 GeV – 1000 TeV**  
**Tibet, 4300 m**

A carpet of RPC (Resistive Plate Counters, faster than scintillators)  
Very good sampling

Tiina Suomijärvi, ISAPP 2003

# Energy Spectra and Experiments

